

PARMA[®]

**Model 12228
Beet Harvester
OWNER'S MANUAL/PARTS BOOK**

Manual Number 04192016-12228

PARMA COMPANY

P.O. BOX 190
PARMA, IDAHO 83660
PHONE (208) 722-5116 FAX (208) 722-6012
Website: www.parmacompany.com

TABLE OF CONTENTS

INTRODUCTION.....	1
DEALER/CUSTOMER CHECKLIST.....	8
SAFETY PRECAUTIONS	2
WARRANTY POLICY.....	10
PRELIMINARY DEALER INFORMATION	
FACTORY TOW AWAY.....	11
UNLOADING THE MACHINE.....	11
SETUP INSTRUCTIONS.....	12
REAR CARRIER WHEEL OPTION	12
LIFTER WHEELS.....	12
LIFTER WHEEL SCRAPERS	13
BELTED CHAIN ASSEMBLY	13
FINAL ADJUSTMENTS AND TEST RUN	17
LIFTER WHEEL PINCH POINTS	17
WHEEL TRACKING (steerable rear wheels only).....	18
GRAB ROLL DRIVE TIGHTENERS	19
ROCK PROTECTION LIFTER WHEEL STRUTS	20
CARRIER WHEEL AND LIFTER WHEEL SPACING.....	20
OPTIONS SETUP AND ADJUSTMENTS	21
ROW FINDER OPERATION	21
ROW FINDER HYDRAULICS.....	23
REAR CARRIER WHEEL RETURN TO STRAIGHT	31
HYDRAULIC SYSTEM	25-30
FRONT VALVE BANK.....	25
HYDRAULIC DIAGRAM USING OPTIONAL VALVE BANK.....	27
HYDRAULIC DIAGRAM, SELF CONTAINED	28
HYDRAULIC SYSTEM RELIEF VALVES.....	29
PUMP AND MOTOR PERFORMANCE.....	29-30
FIELD ADJUSTMENTS	32
TRACTOR PTO & HORSEPOWER REQUIREMENTS.....	32
LIFTER WHEEL PINCH POINT & DIGGING DEPTH.....	32
PADDLE SHAFT HEIGHT ADJUSTMENT	33
GRAB ROLL SPACING ADJUSTMENT	33-34
REAR ELEVATOR.....	34
BEET DELIVERY FROM GRAB ROLLS	35
LOSS OF SMALL BEETS	35
MAINTENANCE SCHEDULE	36
TROUBLE SHOOTING	39
ELECTRICAL DIAGRAM	42
PARTS SECTION	43

INTRODUCTION

This manual has been prepared to acquaint you with the operation and maintenance of your **PARMA Sugar Beet Harvester**, and to provide important safety information. We urge you to read this manual carefully. The recommendations will help assure the safe and trouble free operation of your machine.

When it comes to service, keep in mind that your dealer knows your harvester well and is interested in your complete satisfaction. Your dealer invites you to call him for your service needs both during and after the warranty period.

We thank you for choosing a PARMA product and want to assure you of our continuing interest in your satisfaction. You have purchased a very good machine and with proper care it will give you good service.



SAFETY: THE MOST IMPORTANT SUBJECT OF ALL....YOU CAN LIVE WITH IT!

The Following safety instructions are provided to help assure that all operators of this equipment are trained in its operation and are familiar with the importance of safety in its use.



WITH OWNERSHIP COMES RESPONSIBILITY!

Many times the owner of this equipment is not the operator. The manufacturer delivers the equipment to a dealer, who in turn sells it to an owner. The owner may then assign another person to operate it. With each of these steps it is the duty of the one in possession of the equipment to be sure that the safe operation of the machine is fully explained to the person, or persons, actually operating it. **Do not allow this machine to be used until the following safety material has been reviewed.**

REMEMBER: One of the most common cause of injury or death around this type of equipment is because the operator does not shut the tractor engine off and remove the key when maintenance, adjustments, or cleaning of the machine is conducted!



SAFETY.... YOU CAN LIVE WITH IT!

SAFETY PRECAUTIONS

TAKE NOTE! THIS SAFETY ALERT SYMBOL FOUND THROUGH OUT THIS MANUAL IS USED TO CALL YOUR ATTENTIN TO INSTRUCTIONS INVOLVING YOUR PERSONAL SAFETY AND THE SAFETY OF OTHERS. FAILURE TO FOLLOW THESE INSTRUCTIONS CAN RESULT IN INJURY OR DEATH.



THIS SYMBOL MEANS

ATTENTION!

BECOME ALERT!

YOUR SAFETY IS INVOLVED!

SIGNAL WORDS:

Note the use of the signal words DANGER, WARNING and CAUTION with the safety messages. The appropriate signal word for each has been selected using the following guidelines:

DANGER: Indicates an imminently hazardous situation that, if not avoided, will result in death or serious injury. This signal word is to be limited to the most extreme situations typically for machine components for which functional purposes cannot be guarded.

WARNING: Indicates a potentially hazardous situation that, if not avoided, could result in death or serious injury, and includes hazards that are exposed when guards are removed. It may also be used to alert against unsafe practices.

CAUTION: Indicates a potentially hazardous situation that, if not avoided, may result in minor or moderate injury. It may also be used to alert against unsafe practices.

If you have questions not answered in this manual or require additional copies or the manual is damaged, please contact your dealer.

SAFETY.... YOU CAN LIVE WITH IT



SAFETY.... YOU CAN LIVE WITH IT



EQUIPMENT SAFETY GUIDELINES

Safety of the operator is one of the main concerns in designing and developing a new piece of equipment. Designers and manufacturers build in as many safety features as possible. However, every year many accidents occur which could have been avoided by a few seconds of thought and a more careful approach to handling equipment. You, the operator, can avoid many accidents by observing the following precautions in this section. To avoid personal injury, study the following precautions and insist those working with you, or for you, follow them.

In order to provide maximum safety to the operator or other persons around this machine, various shields and covers have been installed. Keep all shields and covers in place. If shield removal becomes necessary for repairs or any other reason, replace the shield prior to use.

Replace any CAUTION, WARNING, DANGER or instruction safety decal that is not readable or is missing. Location of such decals is indicated in this manual.

Do not attempt to operate this equipment under the influence of drugs or alcohol.

Review the safety instructions with all users annually.

This equipment is dangerous to children and persons unfamiliar with its operation. The operator should be a responsible adult familiar with farm machinery and trained in this equipment's operations. **Do not allow persons to operate or assemble this unit until they have read this manual and have developed a thorough understanding of the safety precautions and of how it works.**

Do not paint over, remove or deface any safety signs or warning decals on your equipment. Observe all safety signs and practice the instructions on them.

Never exceed the limits of a piece of machinery. If its ability to do a job, or to do so safely is in question – **DON'T TRY IT.**



LIGHTING AND MARKING

It is the responsibility of the customer to know the lighting and marking requirements of the local highway authorities and to install and maintain the equipment to provide compliance with the regulations. Add extra lights when transporting at night or during periods of limited visibility.

Lighting kits are available from your dealer or from the manufacturer.

SAFETY DECAL LOCATIONS

The types of Safety Decals on the equipment are shown below. Their locations are shown in the parts section of this manual. Good safety requires that you familiarize yourself with the various Safety Decals, the type of warning, and the area or particular function related to that area that requires your SAFETY AWARENESS.



100409



100403



100311



100407



100406

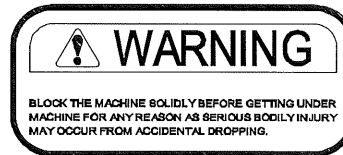

100404



100408

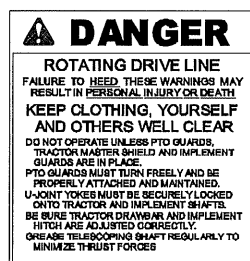

990798



265933

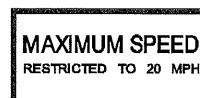

100566

REMEMBER: If Safety Decals have been damaged, removed, become illegible or parts replaced without decals, new decals must be applied. New decals are available from your authorized dealer.



SAFETY DECAL CARE

- Keep safety decals clean and legible at all times.
- Replace safety decals that are missing or have become illegible.
- Replaced parts that displayed a safety decal should also display the current decal.
- Safety decals are available from your Dealer Parts Department or the Manufacturer.

How to Install Safety Decals:

- Be sure that the installation area is clean and dry.
- Decide on the exact position before you remove the backing paper.
- Remove the smallest portion of the split backing paper.
- Align the decal over the specified area and carefully press the small portion with the exposed sticky backing in place.
- Slowly peel back the remaining paper and carefully smooth the remaining portion of the decal in place.
- Small air pockets can be pierced with a pin and smoothed out using the piece of decal backing paper.



REMEMBER!

Your best assurance against accidents is a careful and responsible operator. If there is any portion of this manual or function you do not understand, contact your local authorized dealer or the manufacturer.



BEFORE OPERATING:

- Carefully study and understand this manual.
- Do not wear loose-fitting clothing, which may catch in moving parts.
- Always wear protective clothing and substantial shoes.
- Keep wheel lug nuts or bolts tightened to specified torque.
- Assure that all agricultural implement tires are inflated evenly and with the proper pressure.
- Inspect the machine for any loose bolts, worn parts or cracked welds, and make necessary repairs. Follow the maintenance safety instructions included in this manual.
- Be sure that there are no tools lying on or in the machine.
- Do not use the machine until you are sure that the area is clear of people and animals.
- Don't hurry the learning process or take the unit for granted. Ease into it and become familiar with your new equipment.
- Practice operation of the machine and its attachments. Completely familiarize yourself and other operators with its operation before using.



DURING OPERATION:

- **NO PASSENGERS ALLOWED** – Do not allow any passengers to ride on the machine at any time.
- Keep hands and clothing clear of moving parts.
- **Always disengage PTO and shut off engine before:**
 1. **Leaving Tractor Seat**
 2. **Lubricating**
 3. **Cleaning the machine**
 4. **Adjusting the machine**
- Disengage PTO when turning at the end of a field.
- Always keep safety shields in place.
- Always use adequate lights or safety warnings when transporting machine on public roads and after dark. Check with your local law enforcement agencies for specific requirements.
- Limit towing speed to 20 mph.
- Never stand behind or to the right side of the machine while it is running.
- Always engage PTO drive slowly.
- Before transporting the machine, install an SMV emblem.



FOLLOWING OPERATION:

- Following operation, or when unhitching, stop the tractor, set the brakes, disengage the PTO, **shut off the engine and remove the ignition keys**
- Store the unit in an area away from human activity
- Do not permit children to play on or around the stored unit
- Make sure all parked machines are on a hard, level surface and engage all safety devices



HIGHWAY AND TRANSPORT OPERATIONS:

- Adopt safe driving practices:

Always drive at a safe speed relative to local conditions and ensure that your speed is low enough for an emergency to stop to be safe and secure. Keep speed to a minimum

Reduce speed prior to turns to avoid the risk of overturning



Highway and Transport Operations Cont....

Always keep the tractor in gear to provide engine braking when going downhill. Do not coast

Do not drink and drive!

- Comply with state and local laws governing highway safety and movement of farm machinery on public roads
- Use approved accessory lighting flags and necessary warning devices to protect operators of other vehicles on the highway, during daylight and nighttime transport, in accordance with State Department of Transportation specifications. Various safety lights and devices are available from your Dealer
- The use of flashing amber lights is acceptable in most localities. However, some localities prohibit their use. Local laws should be checked for all highway lighting and marking requirements
- Be a safe and courteous driver. Always yield to oncoming traffic in all situations, including narrow bridges, intersections, etc
- Be observant of bridge loading ratings. Do not cross bridges rated lower than the gross weight at which you are operating
- Watch for obstructions overhead and to the side while transporting

Always operate equipment in a position to provide maximum visibility at all times.



PERFORMING MAINTENANCE:

- Good maintenance is your responsibility. Poor maintenance is an invitation to trouble.
- **Always disengage PTO and shut off engine before:**
 - 1. Leaving Tractor Seat**
 - 2. Lubricating**
 - 3. Cleaning the machine**
 - 4. Adjusting the machine**
- Always block wheels before working on or under the machine.
- Before working under a hydraulically supported assembly, block it securely or lower it to lowest position.
- Use extreme caution when making adjustments.
- When disconnecting hydraulic lines, shut off the pump and relieve all hydraulic pressure.
- Never use your hands to locate a hydraulic leak. Use a small piece of cardboard or wood. Hydraulic fluid escaping under pressure can penetrate the skin.
- Openings in the skin and minor cuts are susceptible to infection from hydraulic fluid. **If injured by escaping hydraulic fluid, see a doctor at once. Gangrene can result.**

Without immediate medical treatment, serious infection and reactions can occur.



Performing Maintenance Cont....

- Replace all shields and guards after servicing and before moving.
- After servicing, be sure all tools, parts and service equipment are removed
- Never replace hex bolts with less than grade five bolts unless otherwise specified. Refer to bolt torque chart for head identification marking
- Where replacement parts are necessary for periodic maintenance and servicing, genuine factory replacement parts are recommended to restore your equipment to original specifications. The manufacturer will not claim responsibility for use of unapproved parts and/or accessories and other damages as a result of their use
- If equipment has been altered in any way from original design, the manufacturer does not accept any liability for injury or warranty

CUSTOMER AND DEALER CHECK LIST

After the machine has been completely assembled (by the dealer or factory), inspect it thoroughly to be certain it is in operating condition before delivering it to the customer. The following checklist is a reminder of points to inspect. Check off each item as it is found satisfactory or after proper adjustment is made.

PRE-DELIVERY:

- Check all sheave and sprocket hubs to make sure they are tight.
- Check the Browning hubs that hold the grab roll drive shafts to the grab rolls to make sure they are tight.
- Check gearboxes to make sure the oil is at the right level. (NOTE: On some harvesters, there isn't a check plug on the gearbox. Refer to page 36)
- Check all grab roll drive power band belts for proper tightness and sheave alignment. (Refer to page 19)
- Grease lifter wheel hubs. Be sure the hubs are completely full. This may take greasing several times during initial digging startup.
- Check the setting of the lifter wheel scrapers. (Refer to page 13)
- Check the bolts in the splice connections in each belted chain to be sure they are snug. Be sure lock nuts are used with the bolts (**Do Not Use Elastic Stop Nuts!**).
- Grease bearings "very lightly" before delivery. (Refer to page 37)
- The tire pressure can be altered to help level the machine and/or eliminate mud buildup. The right hand side is always the heaviest so tire pressure should be at least 5# more on that side. For field conditions the tire pressure should be no less than 20 PSI. If you are moving a considerable distance, the tire pressure should be no less than 40 PSI (doing so with low pressure could cause damage or a breaking away of the tire bead).
- Check the spacing between the spiraled and smooth grab roll pairs and adjust if necessary. (Refer to page 33-34)
- The setting of the row finder is very important to successful harvesting. Be sure it is set correctly. Final adjustments should be made in the field. (Refer to page 21)
- Certain conditions may warrant changing rear elevator to be in a scrubbing mode (if the available option wasn't installed at the factory). (Refer to page 34)

- Check to see that the machine is level in the harvesting position. (Refer to page 18)

DELIVERY:

- Complete the delivery and Warranty Registration Forms, listing the serial number of the machine
- Have the dealer and customer sign the form. Explain the warranty policy on the Warranty Registration Form, and return it to Parma Company.
- Show the customer how to operate the harvester.
- Explain all adjustments.
- Explain the importance of proper lubrication.
- Give the operator's manual to the customer and ask him to familiarize himself with all sections of it.

AFTER EACH SEASON:

- With the machine running, observe operation of moving parts. Watch for faulty operation, overheated bearings and unusual sounds.
- Before storage, thoroughly clean the machine, lubricate thoroughly, and all drive belts and belted chain should adjusted to a relaxed position.
- Machines with belted chain should be stored under cover if possible for maximum life.

WARRANTY POLICY

PARMA COMPANY warrants to each purchaser from an authorized dealer of new equipment manufactured by PARMA COMPANY, that such equipment is, at the time of delivery to such purchaser, free from defects in material and workmanship under normal use, if serviced in accordance with the recommendations of the Operator's Manual. All PARMA COMPANY'S *harvesting equipment products* are warranted for 120 days from the first day of use or 800 acres, whichever occurs first. All PARMA COMPANY *soil preparation* products are warranted for 120 days from first day of use or 1600 acres, whichever occurs first. All PARMA COMPANY *water and waste pump products* are warranted for one year from date of purchase. ALL PARMA COMPANY *forage products* are warranted for one year from date of purchase. Warranty on defective parts purchased by PARMA COMPANY or produced by other manufacturers for PARMA COMPANY may be allowed only after the approval of the vendor or manufacturer.

PARMA COMPANY'S obligation under this warranty is limited to repairing, or at it's option, replacing any part, that in PARMA COMPANY'S judgment, proved defective. Under the terms of the warranty, PARMA COMPANY assumes no responsibility for labor or travel costs involved in removal of defective parts, of installation of new parts, or of any shop supplies or service charges.

All warranty claims are to be initiated through the authorized PARMA COMPANY dealer and **must be submitted within 30 days of the date of failure**. PARMA COMPANY may ask for defective parts to be returned to the factory; therefore, hold all warranty claim parts until advised if the parts are needed by your dealer.

To make the warranty effective, the owner's **Warranty Registration Form** must be on file at PARMA COMPANY, Parma, Idaho at the time of receipt of the warranty claim.

DISCLAIMER OF ALL OTHER WARRANTIES AND CONSEQUENTIAL DAMAGES

THE FOREGOING IS IN LIEU OF ALL OTHER WARRANTIES, WHETHER EXPRESSED OR IMPLIED, INCLUDING ANY IMPLIED WARRANTY OF MERCHANTABILITY OR FITNESS FOR A PARTICULAR PURPOSE, AND THERE ARE NO WARRANTIES, WHICH EXTEND BEYOND THE DESCRIPTION OF THE PRODUCTS. THE LIABILITY OF PARMA COMPANY IS EXPRESSLY LIMITED TO REPAIRING, OR AT ITS OPTION, REPLACING ANY PART THAT IS RETURNED, TRANSPORTATION PREPAID, TO PARMA COMPANY, PARMA, IDAHO, THAT IN PARMA'S JUDGEMENT PROVED DEFECTIVE DURING THE WARRANTY PERIOD. NO REPRESENTATIVE OF PARMA COMPANY, NO DEALER OR DEALER'S REPRESENTATIVE OR ANY OTHER PERSON HAS AUTHORITY TO WAIVE, ALTER, VARY OR ADD TO THE TERMS HEREOF WITHOUT PRIOR APPROVAL IN WRITING SIGNED BY AN OFFICER OF PARMA COMPANY. PARMA COMPANY WILL NOT BE LIABLE FOR ANY OTHER EXPENSE, INJURY, LOSS OR DAMAGE WHETHER DIRECT OR CONSEQUENTIAL, ARISING IN CONNECTION WITH THE SALE OR USE OF OR INABILITY TO USE, ANY PRODUCT OF THE COMPANY FOR ANY PURPOSE.

FACTORY TOW AWAY

Harvester setup for tow away from the factory is available to the dealer. Depending on varying highway restrictions, the harvester discharge boom and draper chain may have to be removed from the harvester.

The front tongue requires a tractor-style draw bar or a special towing ring, which is available through PARMA COMPANY or can be furnished by the dealer.

The harvester as set up for towing **is not field ready** and the dealer will have to perform the final adjustments and test run as indicated on pages 17 through 20.

Warning: Implement tires are **not** rated for towing at highway speeds. The maximum towing speed is 20 mph. If the towing distance is greater than approximately 15 miles, the implement tires should be replaced with appropriate road tires. PARMA COMPANY will not assume any responsibility or liability for any damage done or accidents that occur while towing PARMA equipment. **Tow at your own risk!**

UNLOADING THE MACHINE

When the harvesters are shipped by truck, most of the component parts are either attached to the basic frame assembly, or bundled into the holding tank. Some exceptions to this may be the tongue assembly, rear carrier wheel option, and draper chain. Unloading of the machine from the truck will require two forklifts rated at 10,000 lbs. lift minimum.

Caution: Use extreme care in lifting the machine from the truck, or personal injury and/or damage to the machine may occur. Keep the forklifts as close to the machine as possible when lifting. See Figure (1) for proper lifting method.



SAFETY... YOU CAN LIVE WITH IT!

LIFTING POINTS

Figure (1) shows an example of the forklift positions to unload the machine.

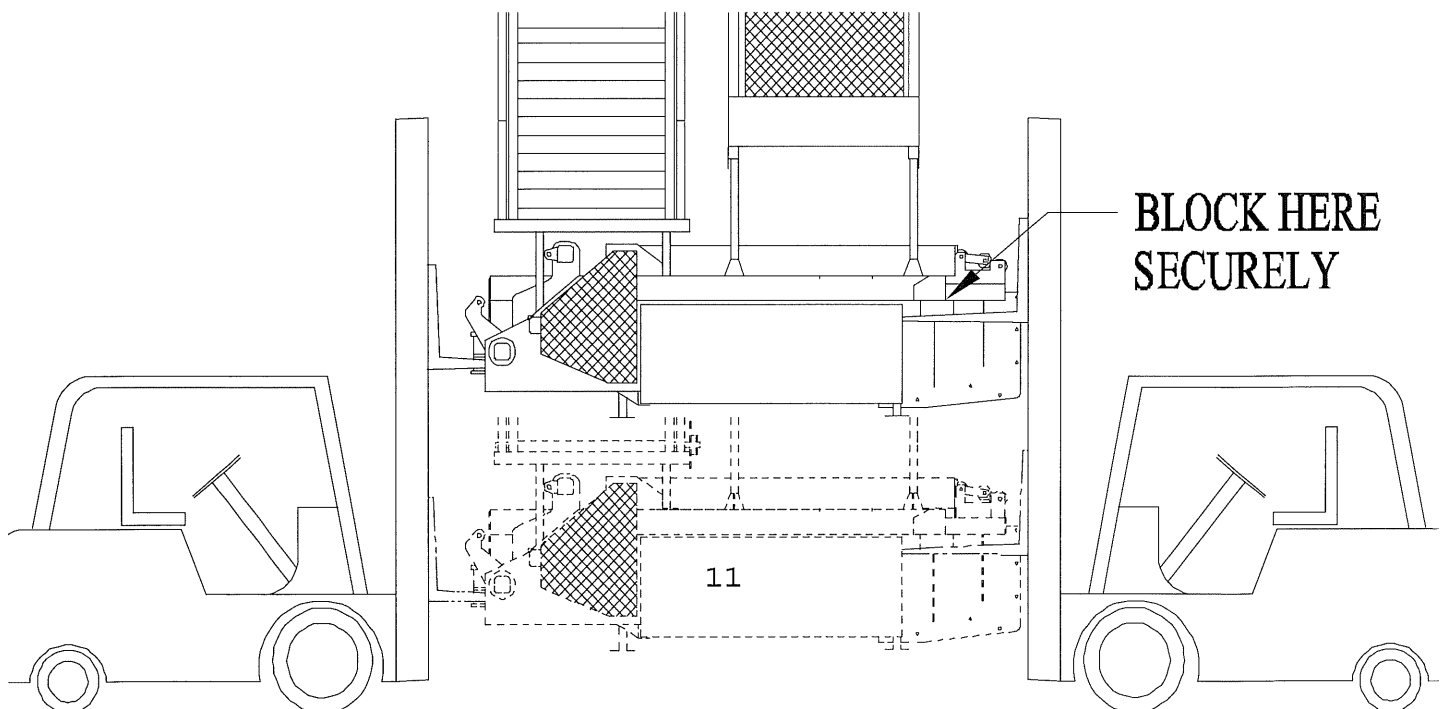

SETUP INSTRUCTIONS

Figure (2) displays the various shipping bundles and parts and their approximate positions when being assembled to the machine. The following steps will help guide you through the assembly process.

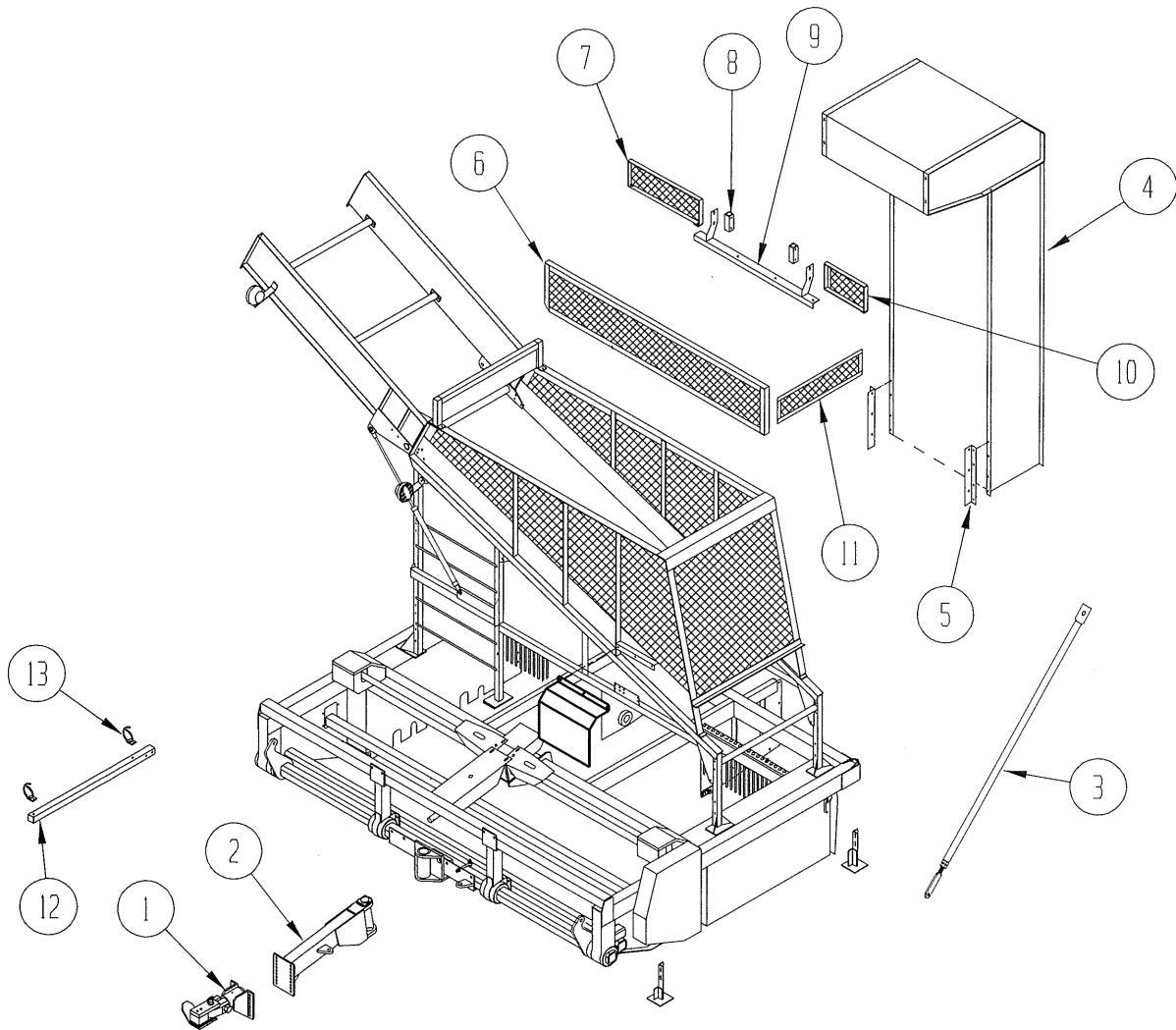

Step 1: Install the rear carrier wheel option using (8) $\frac{3}{4}$ eyebolts and (8) $\frac{3}{4} \times 8 \frac{1}{2}$ hex cap screws with hex nuts and lock washers. Refer to carrier wheel and lifter wheel spacing diagram page 20. **Refer to page 18 for important leveling information.**

Remove all shipping stands and place blocks under the left and right front corners of the main frame. The blocks should be high enough to allow clearance to install the lifter wheels.

Step 2: Install all lifter wheels and the desired amount of wheel spacers using $\frac{1}{2} \times 3$ hex bolts, hex nuts, and lock washers furnished. (See page 17 for additional information on pinch point width adjustment.) For rock cushion option installation, see instructions enclosed with option.

Setup Continued:

Step 3: Install lifter wheel scrapers using (2) 1/2 x 4 1/2 hex bolts, hex nuts, lock washers and shims furnished as shown in Figure 3. Install with the tips of the scrapers, items #2 & #3, close to the corner of the wheel hub and wheel. Add or remove shims, item #3 as necessary. Tighten securely.

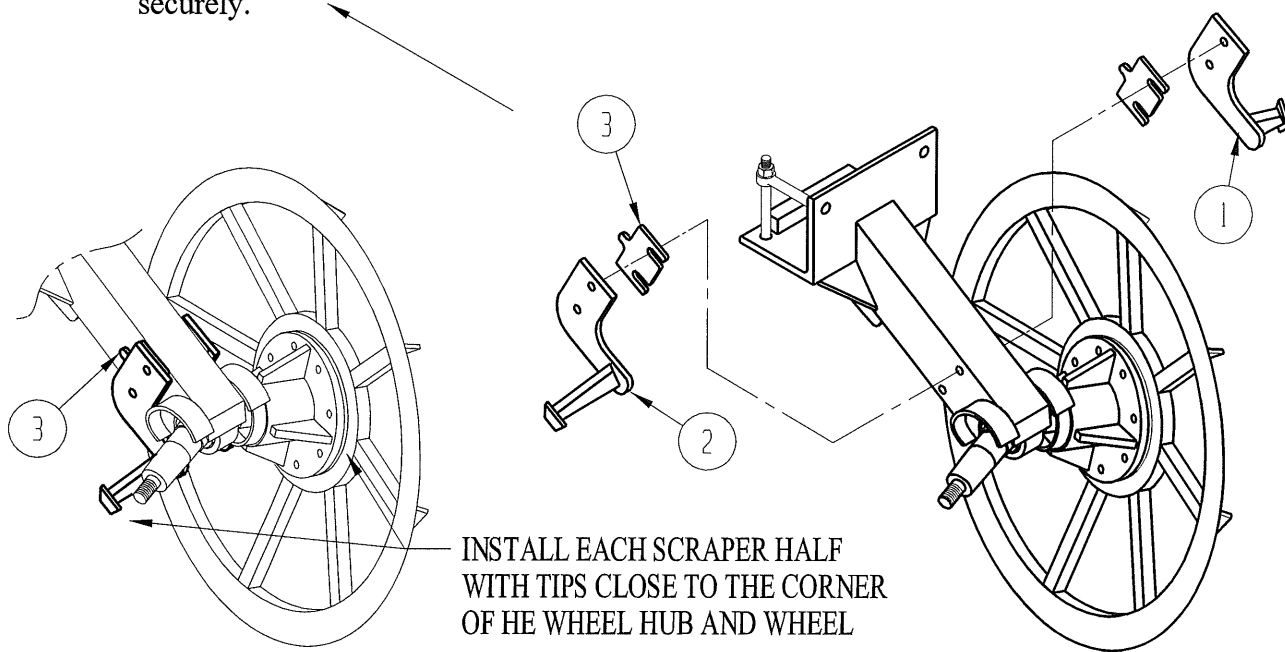

Step 4: **Important!!** The rear elevator frame assembly may have shifted during shipment and may out of square. Be sure to cross measure both the vertical and top panels to be sure they are square with each other before assembling the belted chain. To straighten, loosen all the spreader bar bolts while the unit is setting on a level/straight surface. Re-tighten bolts after adjustments are made. Install the belted chain on the inside and outside of the rear elevator prior to installing the elevator. It is easier to install the chain if the elevator frame is turned so the backside is up and away from the floor.

Install the rear belted chain so the offset rods are to the rear. Install the front chain so the offset rods are to the front. The chain will come cut to the proper length and shouldn't have to be modified. It is critical that the belts are installed with the overlap in the direction shown in Figure (4). See page #15 for more instructions after the elevator is installed.

Step 5: With the use of a fork lift or other suitable means of lifting, lift the rear elevator into place and attach lower support angles (Item #5, Figure 2) to main frame using (8) 5/8 x 3 hex bolts, nuts, lock & flat washers. Do not completely tighten the nuts at this time.

Step 6: Attach the top elevator mounting brackets (Item #7, Figure 2) to the hopper and then bolt the elevator discharge panels to these brackets. Now, after re-checking to be sure the elevator frame is still square, tighten all bolts and nuts securely.

Step 7: Wrap the lower end of the rear belted chain around the rollers as shown in Figure #5, pg. 14, or the decal on the side elevator panel. Attach the ends of the belts along with the chain rods and backing clamps furnished, being sure that the overlap connection is in the direction illustrated in Figure 4. Tighten the lock nuts on the bolts until they are snug and secure. Be sure

lock nuts are used with the bolts (**Do Not Use Elastic Stop Nuts!**).

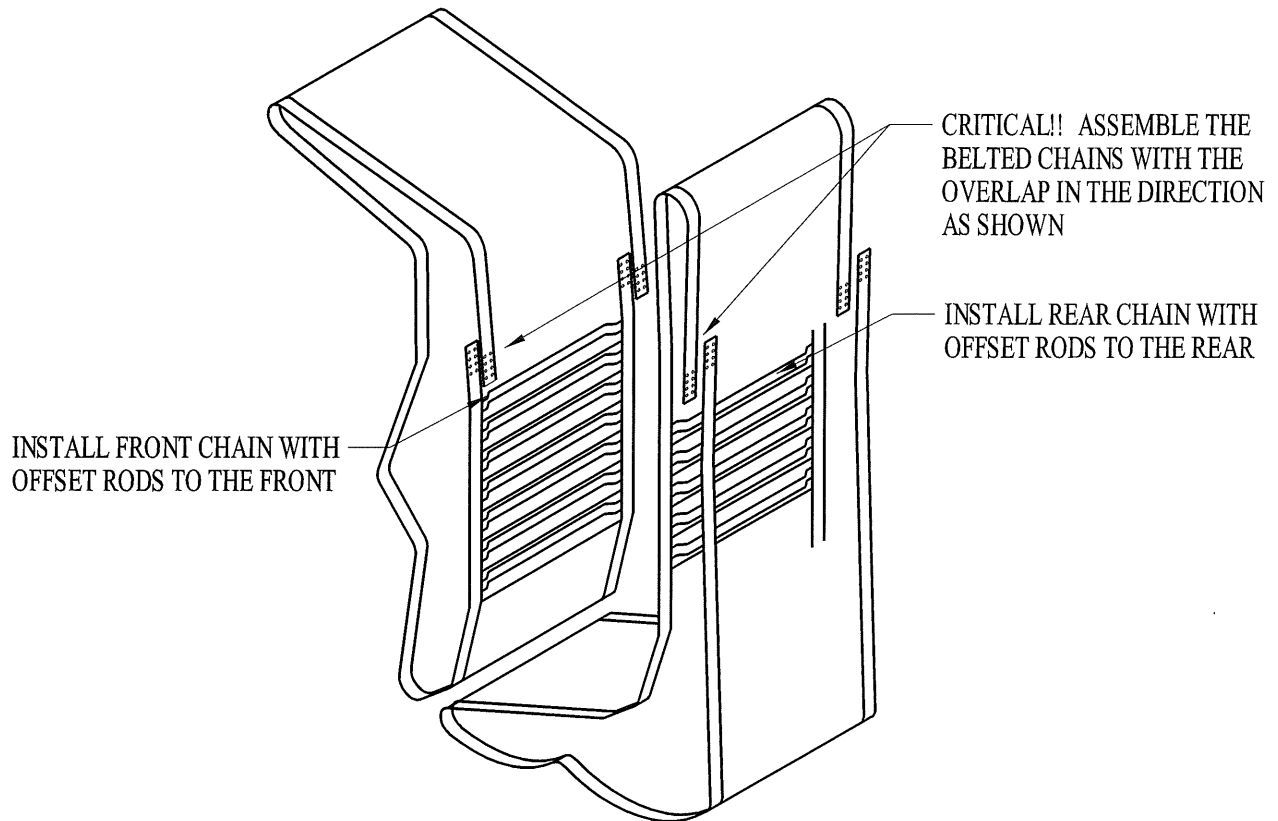

FIGURE 4

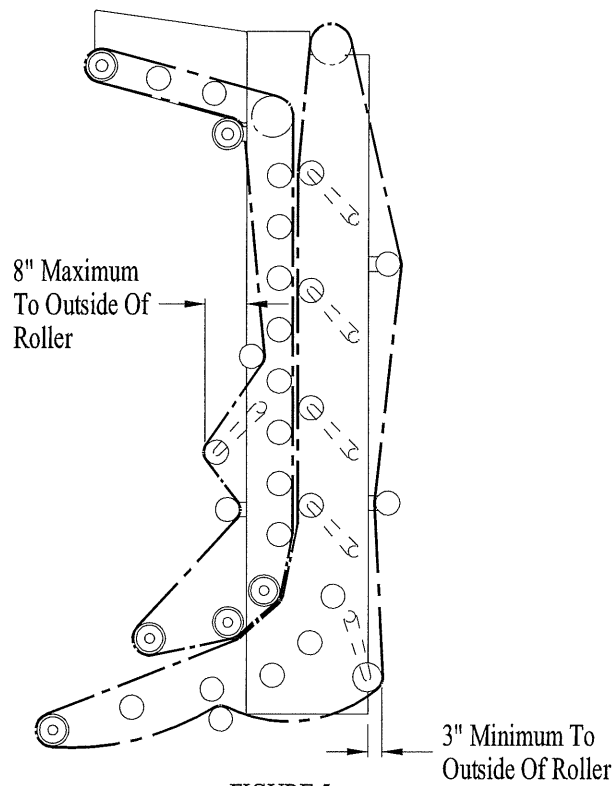

FIGURE 5

Setup Continued:

Double-check the spacing between the rollers in the elevator. There should be approximately 3/16"-1/4" clearance between the outside edge of the rollers and the inside of each belt. Adjust by adding or removing washers as necessary.

Install all hugger springs as shown in figure #6. **Be sure to adjust the tightener arm stops** as shown in Figure #6. This will keep the rods in the belted chain from catching each other when the chain is in the scrubbing mode.

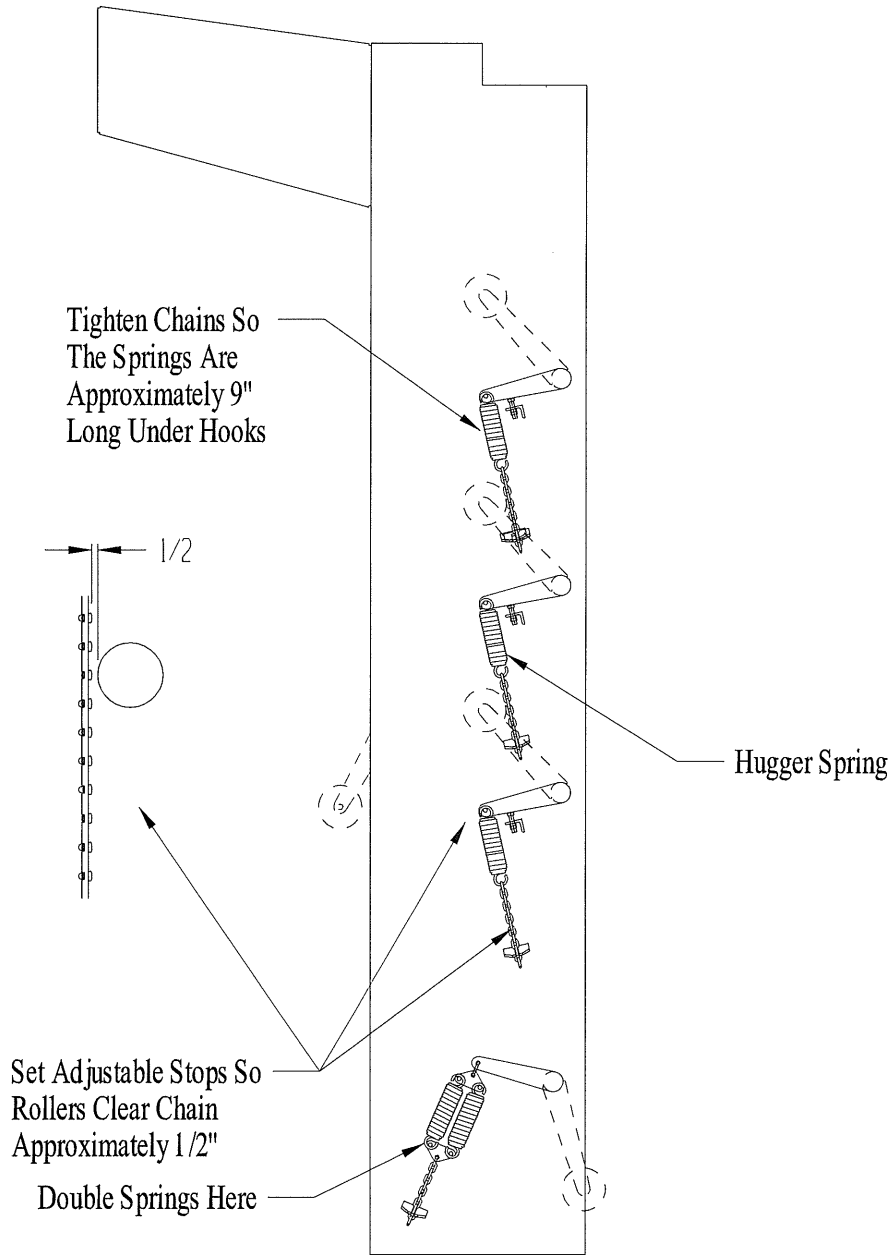

FIGURE 6

Setup continued:

Step 8: Install the support rod assembly (Item #3, Figure 2.) on the right hand side of the frame using (2) 5/8 x 1¼ hex bolts, hex nuts and lock washers.

Step 9: Install all hopper railings (Items #5, #6, #7 & #8, Figure 2).

Step 10: Install the tongue assembly (Item #2, Figure 2) and the heavy-duty swivel hitch

Step 11: Install the hose holder and hose rings to the front of the machine. See Figure 7 for proper positioning.

Step 12: Connect all hydraulic hoses and check fittings for tightness. **Be sure the pressure line from the tractor is connected to the "P" port of the harvester valve bank or the system will not work properly.**

Note: The optional solenoid valve bank used on the harvester is furnished from the factory set for closed center tractor hydraulic systems. To convert the valve bank for use with open center hydraulic systems, remove the long screw located on the unloader valve (the end valve on the RH side as viewed from the front of the machine) and replace it with the short screw located in the body of the same valve. Be sure to place the long screw in its place for possible future use. See pages 23 & 24 for use of open/closed center hydraulics with the row finder.

These previous steps will complete the assembly of the basic machine. For two way steering instructions, see page 31.

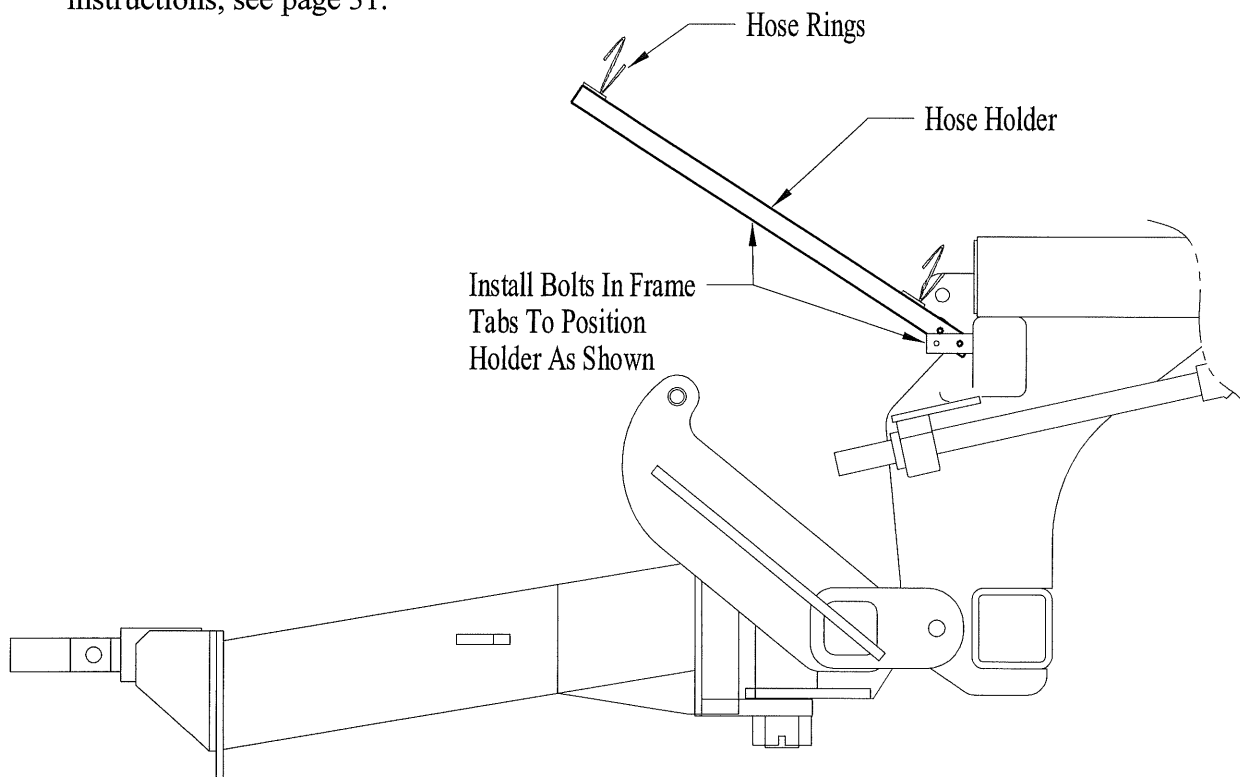

FIGURE 7

FINAL ADJUSTMENTS AND TEST RUN

CHECK THE ELECTRICAL CIRCUITS:

Check by operating control switches on switch box. If any problems are present, refer to electrical diagram on page 33.

INSTALL THE PTO DRIVE LINE (and connect to 1000 RPM tractor PTO).



WARNING! Measure the length of the PTO drive line after installation. The operating length range is **60" min - 70" max on the standard PTO and 60" min - 65" max on the constant velocity PTO.** Adjust the tractor draw bar if necessary.

CHECK LIFTER WHEEL PINCH POINTS:

The lifter wheel pinch point width and accuracy of the row spacing between the lifter wheel struts can be a **major cause of beet breakage and amount of dirt being lifted** into the harvester. Figure #8 shows the desirable way to check spacings to help assure the best performance in lifting of beets without breakage. It is most important that all the pinch point widths on the harvester be the same within 1/4". Refer to page 32 for additional information.

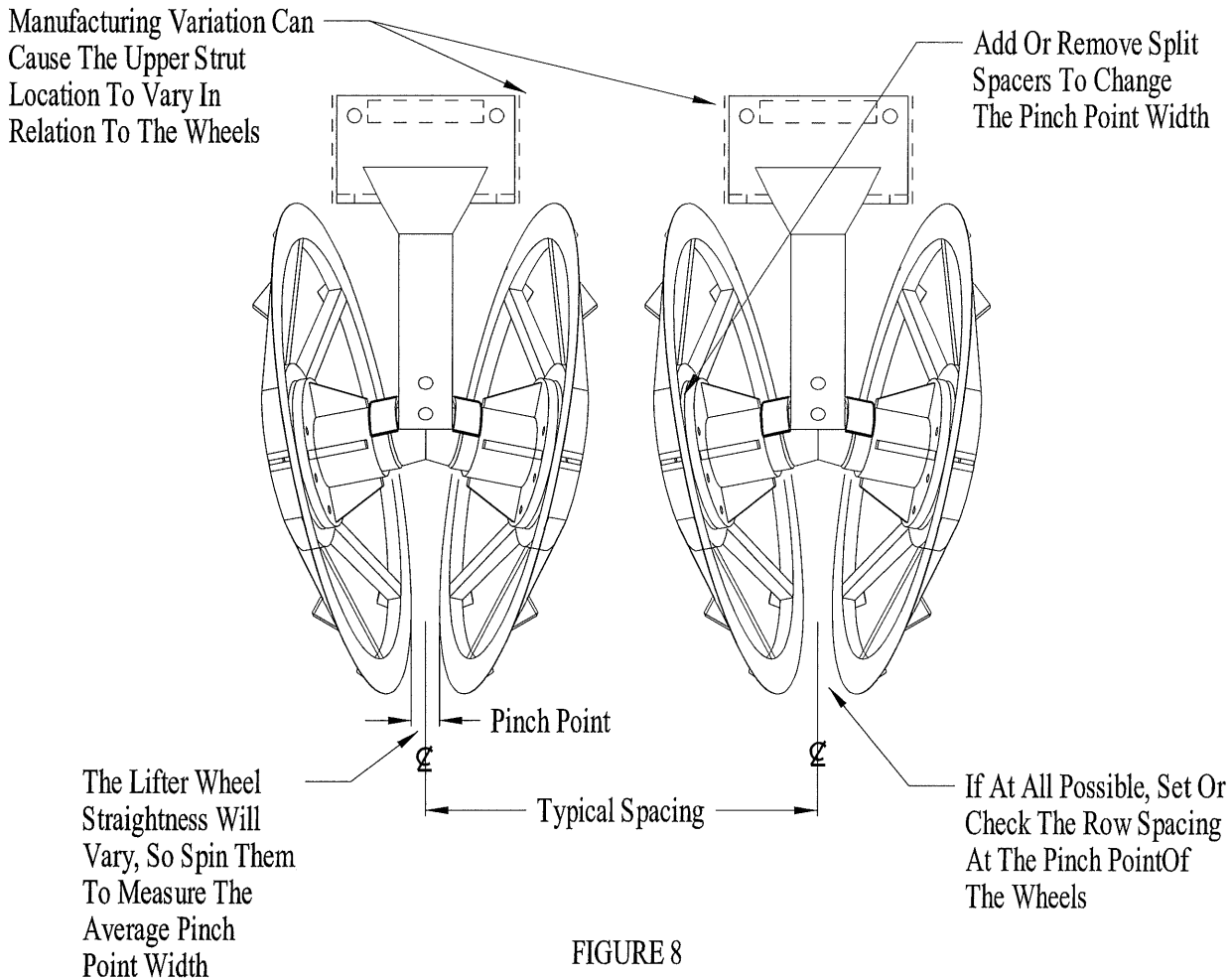

FIGURE 8

WHEEL TRACKING (steerable rear wheels only):

In addition to being sure that the rear steerable wheels are set at the proper spacing, we have found that in some conditions, if some toe-in is set on both sides, the harvester will track better (Figure #9).

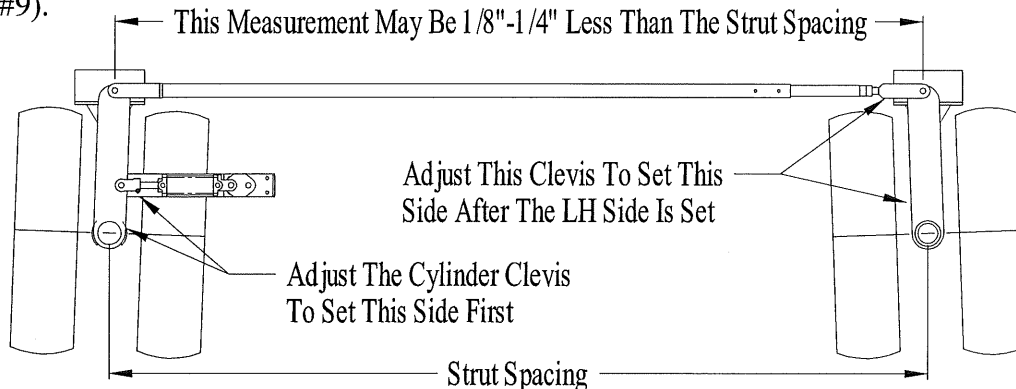

FIGURE 9

MACHINE TO BE LEVEL:

It is important that the harvester is approximately level front to back during the digging operation. The Final adjustment may have to be necessary after the machine gets to the field to accomplish this, however, a good rule of thumb is: **For flat dry land furrows** with non steerable wheels, use the lowest rear wheel position. **For deeper irrigated furrows** with steerable wheels, use a mid-range wheel position. Refer to Figure #10 for additional explanation. Note that in some conditions, the RH (heavy) side of the harvester may have to be adjusted slightly higher than the LH side to compensate for soft ground, muddy conditions, or other ground level differences.

If the Pintle hook hitch option is used, be **sure the ring portion attached to the tongue slopes up rather than down** or the safety latch on the hook will be damaged.

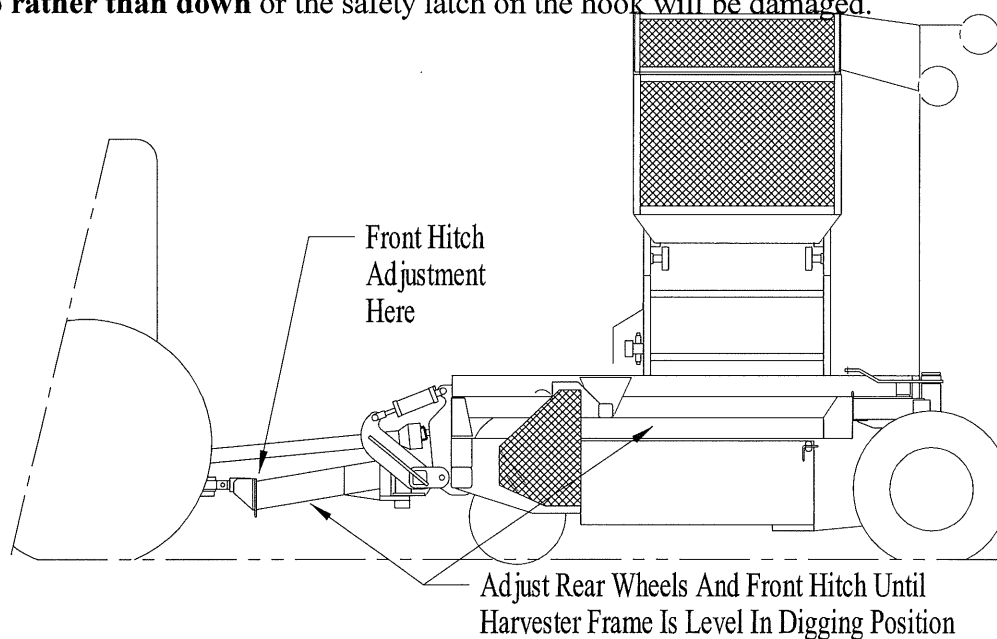

FIGURE 10

DRY RUN THE HARVESTER:

Run the machine for 20-30 minutes to allow the drive belts, roller chains, and draper chains to “seat in”. **When the run-in is complete, readjust all drives and check for possible misaligned sprockets or sheaves.** Check the hopper and rear elevator draper chains for correct alignment and if hook style chain is used, recheck the positions of the tightener rollers as described in Figure #5 and remove links if necessary.

RE-CHECK THE GRAB ROLL DRIVE TIGHTENERS:

It is important that the spring tighteners on the grab roll drives are adjusted properly. Refer to Figure 11 for instructions. If for any reason, either or both of the power band belts are removed, be sure to adjust the tighteners, dry run the machine for a few seconds and then readjust the tighteners. Failure to do this may cause failure in the belts.

To Tighten the Belts: Back off the lower hex nuts to allow 1"-2" clearance. Then tighten the spring until it's almost fully compressed. Run the drive to see that the belts are seated into the sheave grooves. Retighten the spring until the distance between the coils is approximately the width of a quarter, then retighten the hex nuts.

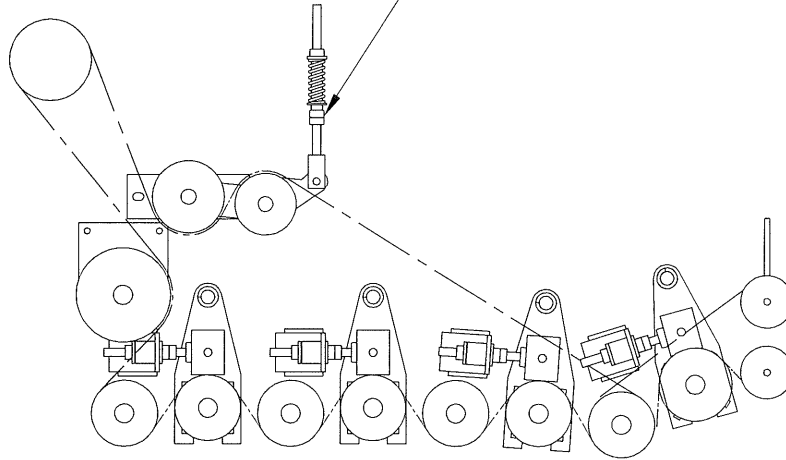

FIGURE 11

AFTER THE RUN-IN IS COMPLETE

Review all of the lubrication checkpoints listed on the maintenance schedule on page 36 and lubricate the entire harvester according to the item explanations. **Important: Be sure the slide joint on the PTO driveline is thoroughly greased** before the machine is placed in operation. This is often overlooked. Lack of grease in this area may cause premature failure in the joints and possible damage to the tractor PTO.

Optional Rock Protection Lifter Wheel Struts and Lifter Wheel Cushions:

If the optional rock protection lifter wheel struts and/ or lifter wheel cushions are installed, check the tightness of the bolts holding all plastic cushions. The bolts should be tightened just enough to securely hold, but compress the cushions very little. The paddle shaft should be adjusted to have at least 2" clearance from the lifter wheels (the distance may vary depending on the condition) and the optional rubber backing paddles should be installed.

CARRIER WHEEL AND LIFTER WHEEL SPACING

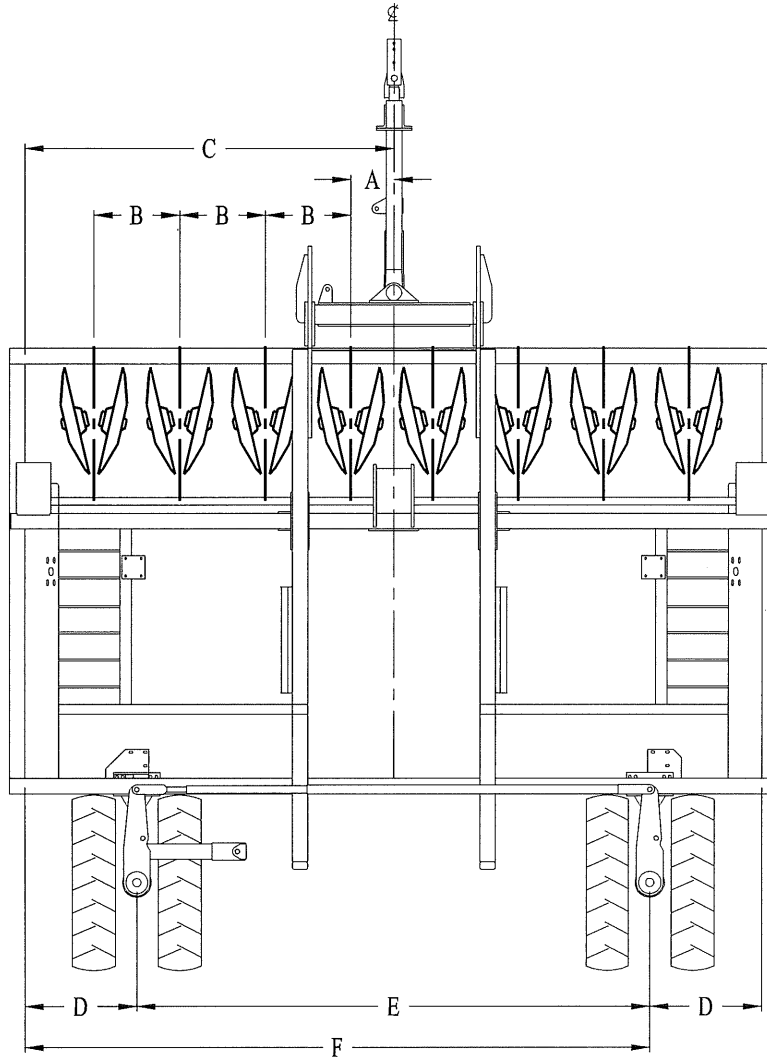

****NOTE:** In dry land planting & wet conditions, set one of the carrier wheels into the dug row.

SPACING	A	B	C	D	E	F
6-21"	10 1/2"	21"	72 3/4"	20 1/4"	105"	125 1/4"
6-22"	11"	22"	72 3/4"	17 3/4"	110"	127 3/4"
6-30"	15"	30"	94 3/4"	19 3/4"	150"	169 3/4"
8-22"	11"	22"	94 3/4"	17 3/4"	154"	171 3/4"

OPTIONS SETUP AND ADJUSTMENTS

ROW FINDER OPERATION:

During the operation of the harvester, **the row finder, if used, plays the largest single part in keeping the machine on the row and allowing the lifting of beets without breakage.** Therefore **it is essential that it be set and adjusted correctly, and the operator fully understands its operation.** The most preferred location of the row finder is attached to the lifter wheel strut next to the tongue on the side of the harvester nearest where the trucks run. Refer to the illustration in Figure #12, for proper mounting and adjustment.

1. Attach the mounting bracket (Item #1), assembled to the row finder, to the lifter wheel strut mounting bolts.
2. Disconnect the turnbuckle attached to the control valve (Item #2), and adjust the centering springs to have a minimal clearance to the control arm and so the springs are the same length.
3. Move the tension plate (Item #3) until the fins are directly in line with the pinch point of the lifter wheels. Then reattach the turnbuckle. Be sure to adjust it so there is no pressure against the valve spool.
4. The width of the fin tails should be approximately $\frac{1}{2}$ inch wider than the average beet size at ground level. To adjust the width, loosen the fin mounting bolts (Item #4) and add washers to the inside of the lower or upper bolts as required.
5. Using the up/down adjusting nuts (Item #5), move the fin tails to have approximately 4 inches of ground contact. More contact than that may cause the control of the row finder to be erratic. The adjusting bolt on the mounting frame (Item #7) may have to be turned up or down to provide ground clearance for the correct fin tail angle.
6. Adjust the down pressure on the fins with the spring adjustment (Item #6) just enough to eliminate fin bouncing.
7. Grease the pivot shaft that the fins are attached to thoroughly to insure free movement of the fins.

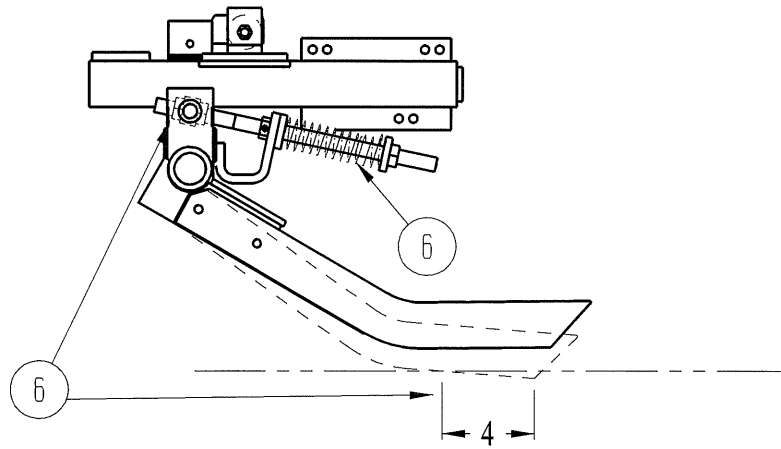
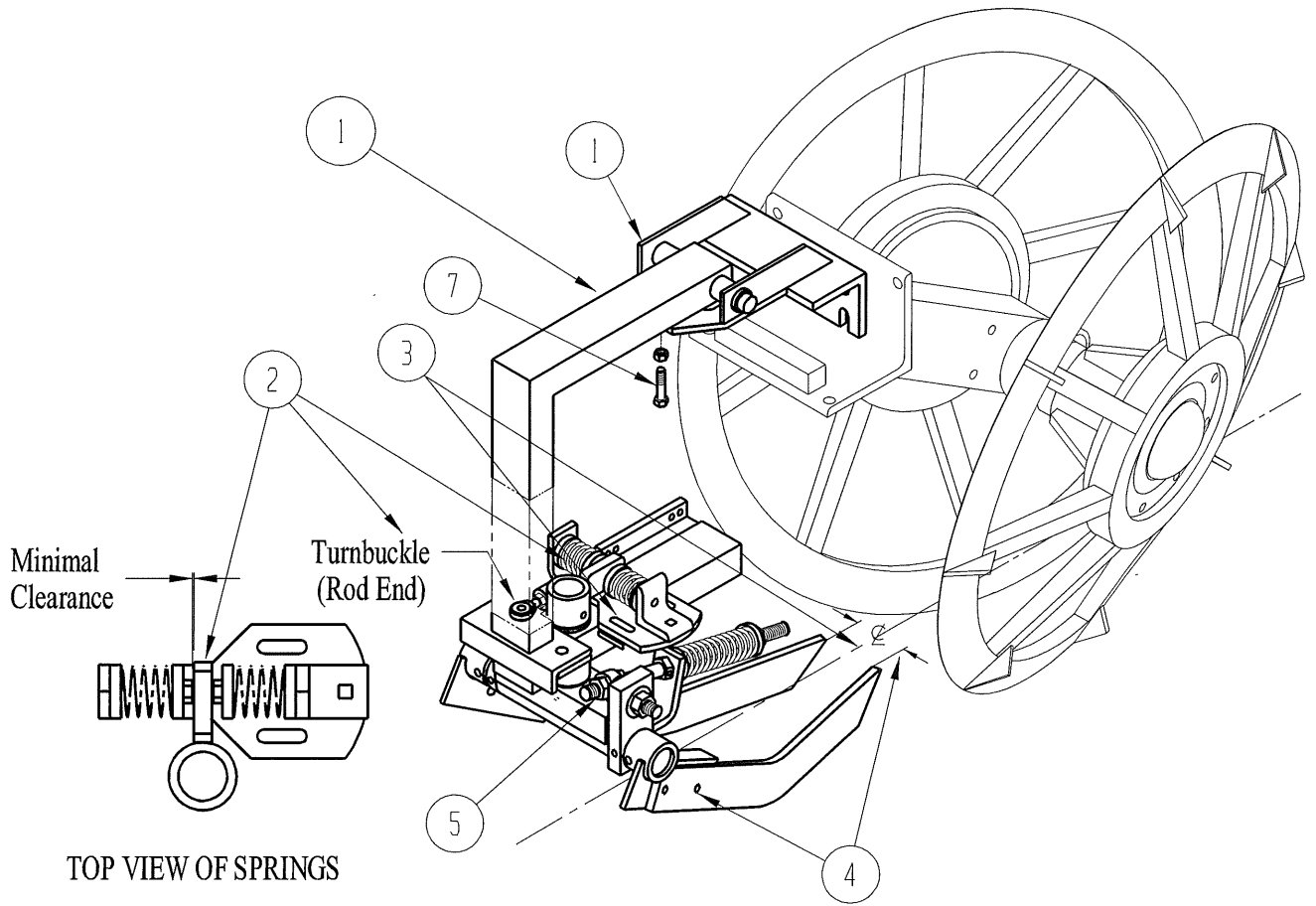

ROW FINDER HYDRAULICS:

1. The row finder valve will work for both open and closed center hydraulic systems. The valve is furnished for use with closed center hydraulics. To convert to open center, remove the 3/8" socket hex head pipe plug from the port in the outlet port (Figure 13, Item #1). To convert back to closed center, reinstall the same plug to the port that it was taken from. See page 24 for row finder plumbing, open or closed center hydraulics.

2. The hydraulic valve on the row finder has had the internal pressure relief preset at 1500 PSI. On most tractors, the hydraulic pressure is 2000 PSI or above. If you experience a squealing sound in the valve (pressure bypass) adjust the valve pressure relief until the squealing sound stops. Adjust the relief pressure by removing the acorn nut (Figure 13, Item 2), and turning the adjusting screw. Turn the screw clockwise to increase the pressure and counter clockwise to decrease the pressure.

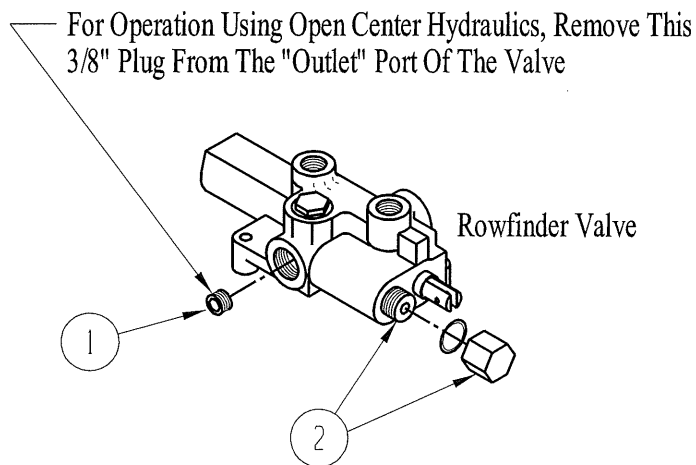
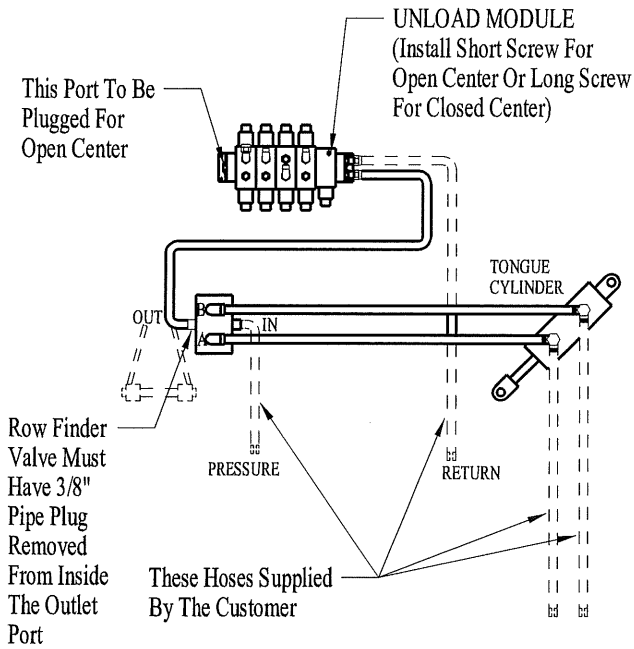
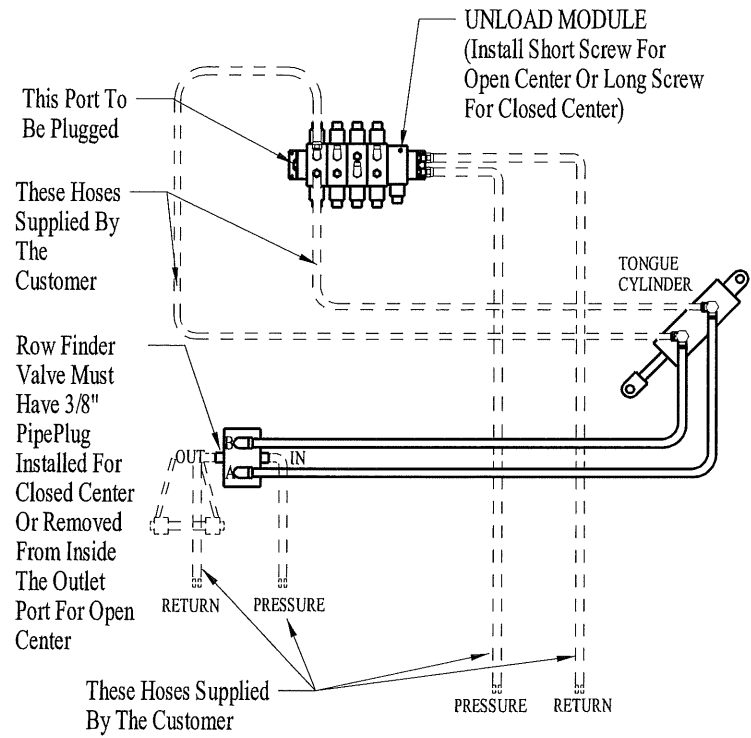

FIGURE 13



OPEN CENTER HYDRAULICS
 PLUMBING USING TRACTOR VALVE OVERRIDE



OPEN & CLOSED CENTER HYDRAULICS
 (Plumbing Using Tractor Power Beyond And Valve Bank Override)

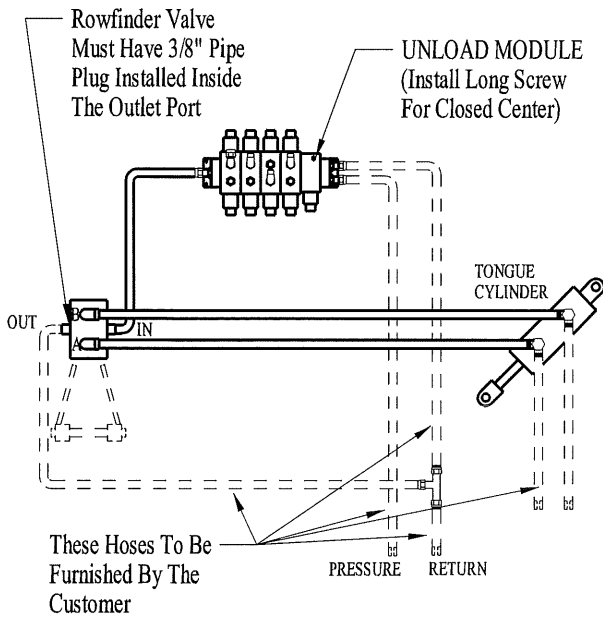

CLOSED CENTER HYDRAULICS
 (Plumbing Using Tractor Valve Override)

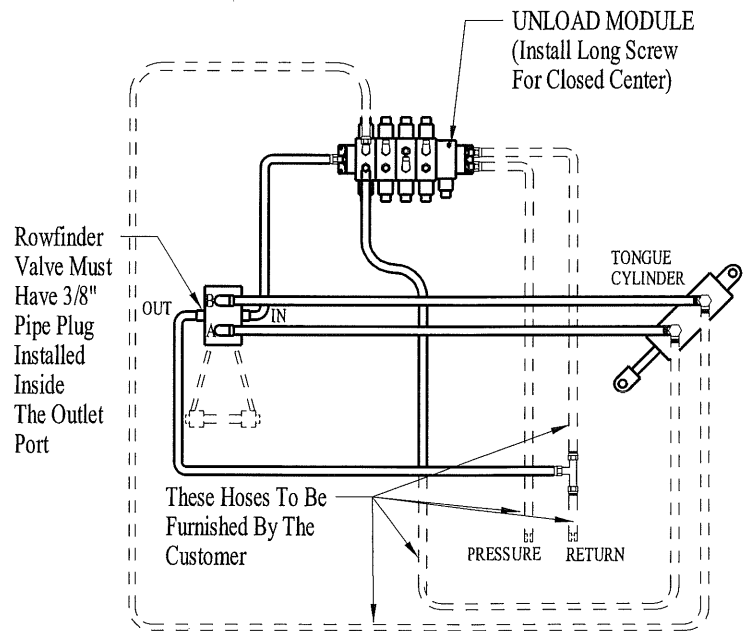

CLOSED CENTER HYDRAULICS
 (Plumbing Using Valve Bank Override)

ROW FINDER HYDRAULIC PLUMBING

HYDRAULIC SYSTEM

Front Control Valve Bank:

The valve bank is an optional item that can operate all the hydraulic cylinders on the harvester. The amount of valves required will depend on the harvester model and the amount of hydraulic outlets available from the tractor.

It is a unit made of precision parts and four things can affect its performance most commonly:

1. **Oil flow from the tractor is in excess of the capacity** of the valves and causes the valve spools to float and malfunction. The **maximum** flow allowable through the valves is **21 G.P.M.** Most tractors provide in excess of 20 G.P.M. so check the flow prior to operation. Backpressure, due to excess flow, against some tractor systems can cause malfunctioning in the secondary remote outlets.

In most cases the harvester **lift cylinders are connected to the priority remote, and valve bank should be connected to the secondary remote on the tractor.** If the steering cylinder (or row finder override) is connected directly to the tractor, it should be connected to the secondary remote and the valve bank to the third remote.

2. Oil from the tractor can flow through the valve bank in only one direction without causing a malfunction. The valve ports are marked with **"P" for pressure and "T" for tank.** It is important that the lines from the tractor are connected correctly.

3. The valve bank is set for open center hydraulics but the tractor system is closed center. **Some tractors have systems that are advertised to be useable as both open and closed which may cause problems.** The dealer and farmer should be aware of the limitations of the tractor system and how the harvester needs to be plumbed before going to the field.

4. Dirt contamination in the oil (even the smallest speck sometimes) can cause the spools to stick.

The next page shows illustrations and notes of and about the valve bank. Review it and even highlight some of the important items such as:

1. Pressure and return ports.
2. Location of screws that allow the valve to operate with open or closed center tractor hydraulic systems.
3. Removal and reassembly of the valve spool. **Don't forget the small pin, which can be lost easily.**
4. Oil cleanliness.

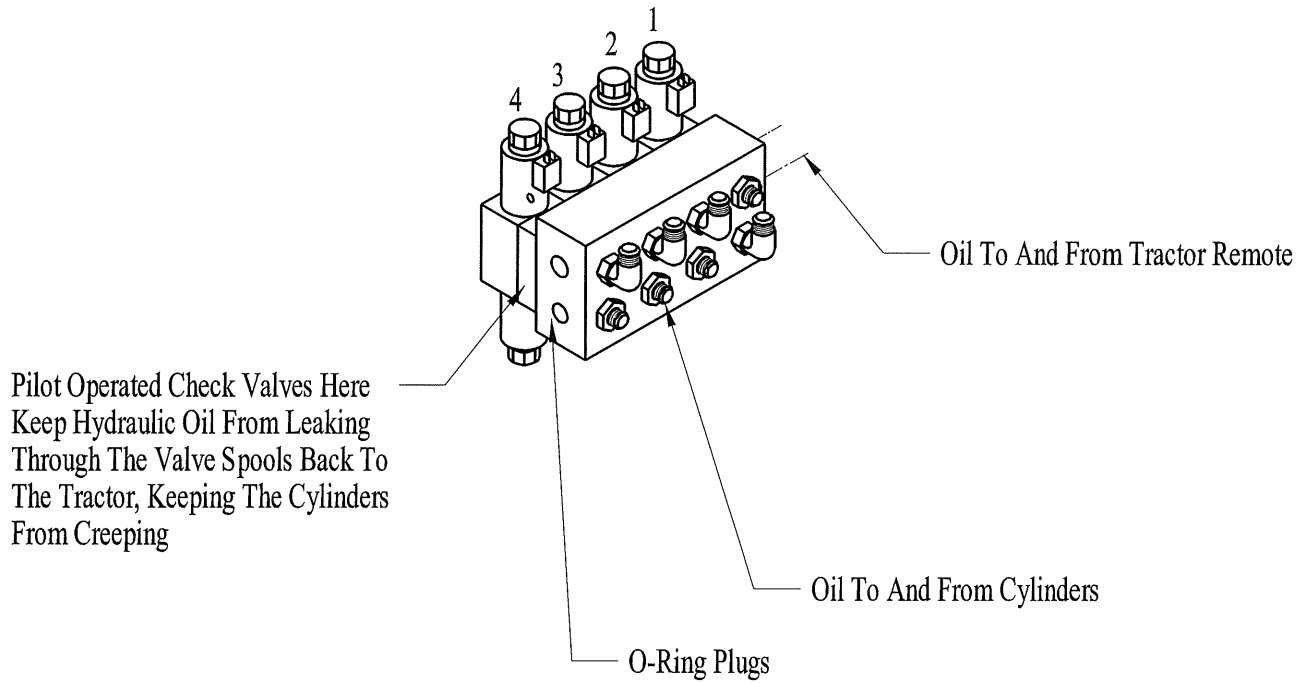

STANDARD VALVE FUNCTIONS		<u>REMEMBER:</u> Oil Flow Rate In Excess Of 21 GPM And Oil Contamination Are The Primary Causes For Valve Malfunction TURN THE FLOW DOWN! KEEP THE OIL CLEAN!
VALVE		
4	ROWFINDER	
3	STEERING	
2	STEERING	
1	BOOM	

FRONT VALVE BANK OPERATION

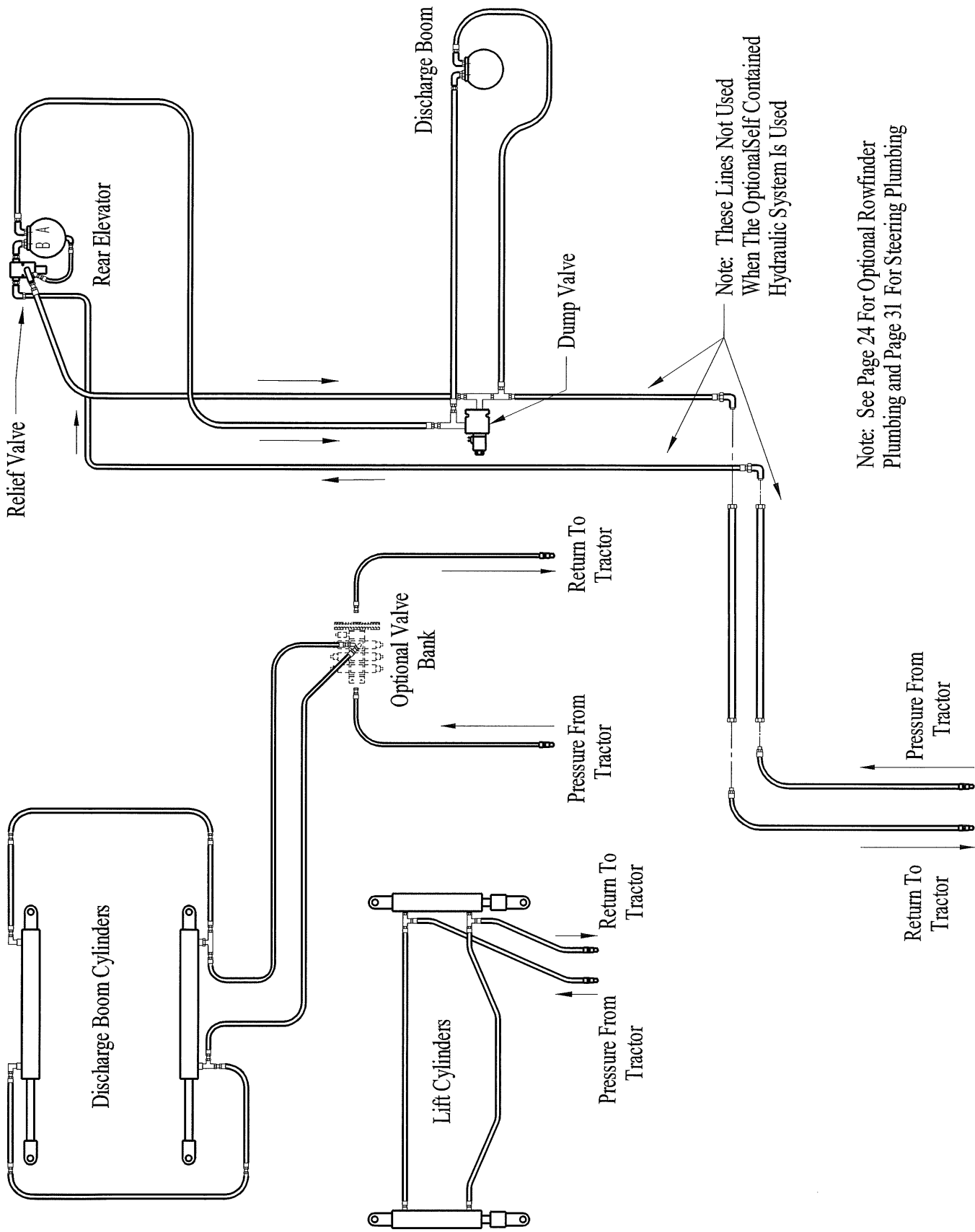

Note: These Lines Not Used
When The Optional Self Contained
Hydraulic System Is Used

Note: See Page 24 For Optional Rowfinder
Plumbing and Page 31 For Steering Plumbing

HYDRAULIC DIAGRAM USING TRACTOR HYDRAULICS

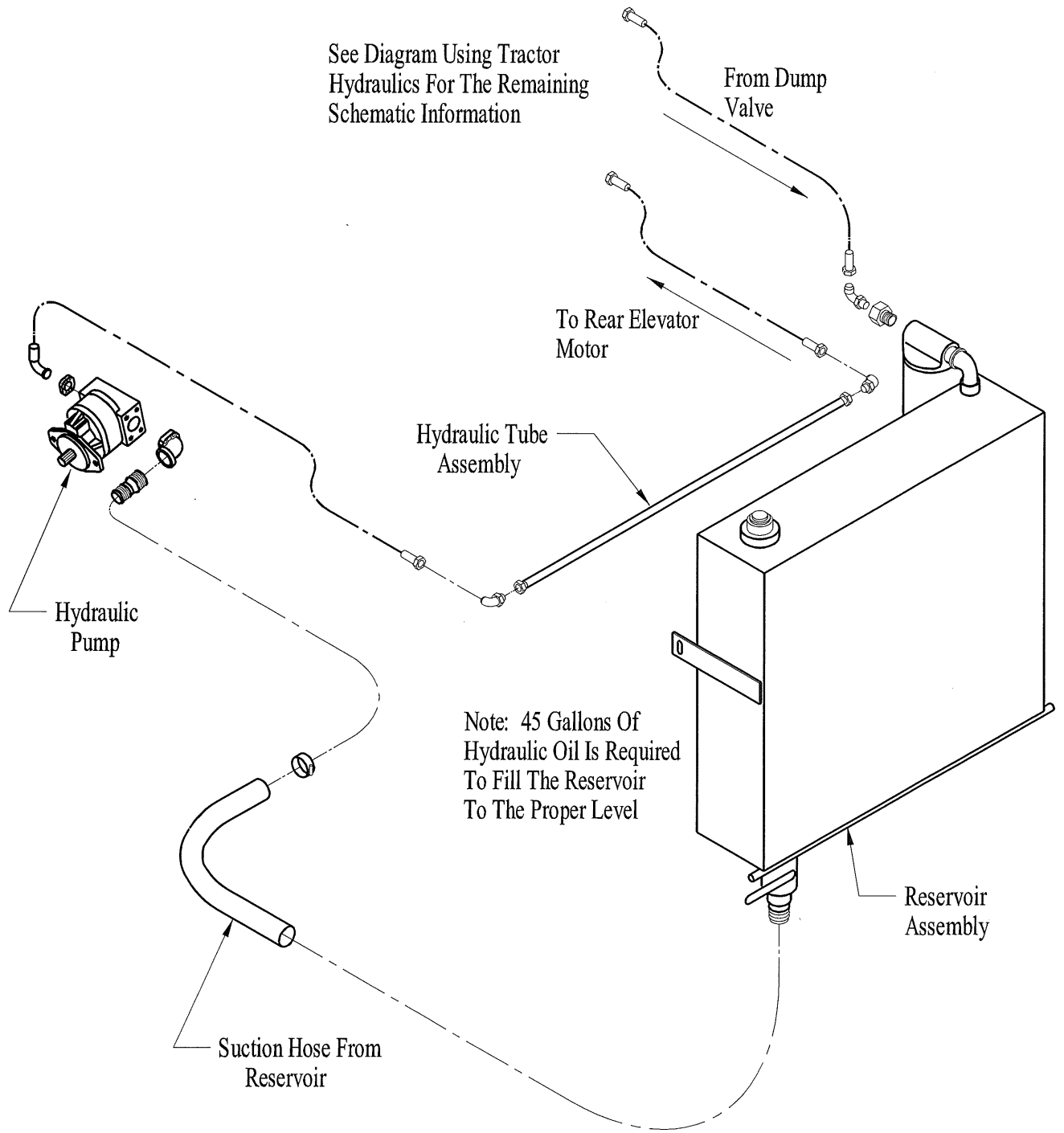

HYDRAULIC DIAGRAM, SELF-CONTAINED OPTION

HYDRAULIC SYSTEM RELIEF VALVES:

The relief valves in the harvester hydraulic system is normally set to 3500 PSI from the factory. Periodically, we have found one that is not and would be set at 1000-2000 PSI. In most cases, when this happens, the valve has to be reset for the harvester to operate correctly. The illustration below shows how to do that.

Be aware that the valve has the capability of reaching 6000-PSI relief pressure and **it is crucial that caution be taken, if readjustment is required, that the setting not exceed 3500 PSI or damage may occur to the hydraulic components.** The purpose for the difference between the 3500-PSI recommended setting and the 6000-PSI maximum capability is to prevent damage to the relief valves when pressure spikes occur due to occasional rock jamming in the harvester.

One clockwise turn of the adjusting screw increases the pressure by 1200 PSI. If a pressure gauge is not available, and the valve has to be reset, turn the adjusting screw clockwise until the snap ring on the screw contacts the lock nut. The pressure at this setting will be 6000 PSI. (**Caution: DO NOT FORCE THE SCREW INTO OR PAST THE RETAINING SNAP RING**). At this position, turn the adjusting screw counter clockwise 2 1/2 turns. The pressure setting at this position will be approximately 3000 PSI, which will be adequate for 90% of the conditions.

NOTE: the above information applies only to Sun brand Relief Valve Cartridges #RPGC-JCN (Parma Part Number 264887).

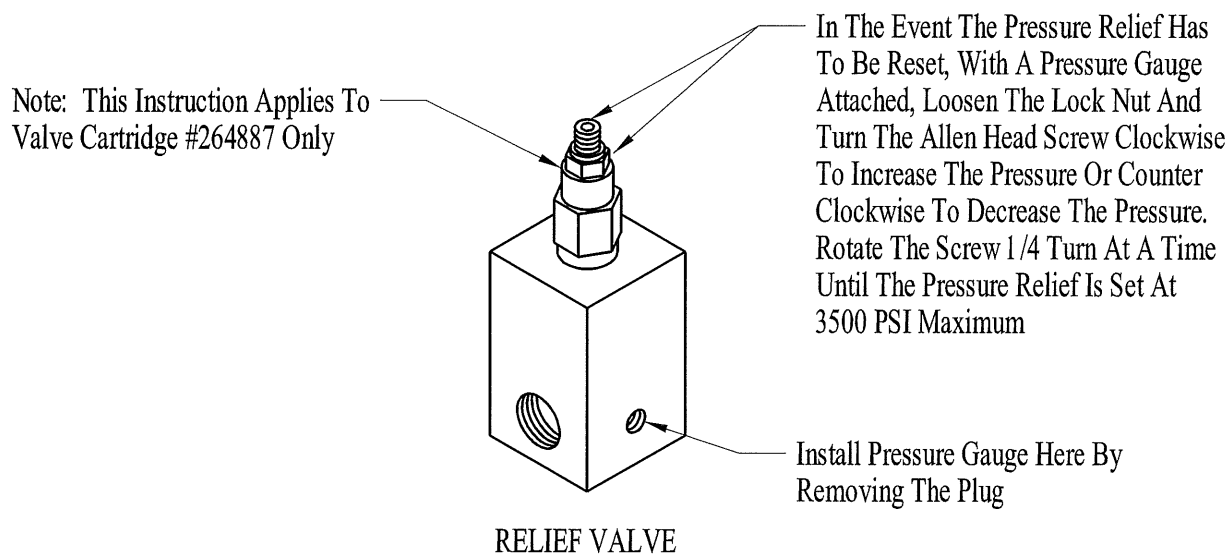

PUMP AND MOTOR PERFORMANCE:

If a hydraulic motor unexpectedly slows down or operates substantially slower under heavy load (extreme digging conditions) it may be caused by several conditions:

1. The relief valve pressure setting is too low
2. The relief valve is defective.
3. The harvesting conditions are causing loads against the system that are exceeding its capabilities
4. The motor is defective
5. The pump is defective

Pump and motor performance continued:

The cause of the problem can be found easily by following these steps:

1. With a pressure gauge installed in the appropriate port shown on the previous page, the hydraulic circuit can be “stalled” by disconnecting the motor discharge hose at the reservoir end. Look at the oil dripping out of the motor. If it has metallic substance in it, the **motor is likely excessively worn** and may have to be replaced.
2. Cap the hose, then very slowly engage the tractor PTO and read the pressure setting on the gauge. If the reading is at 3500 PSI, or the relief valve can be adjusted to get that reading, **then the system is OK** and likely the harvesting conditions are causing excess loads above the rated capacity of the system. If you cannot adjust the pressure with the valve screw as shown on the previous page to the proper setting, then **one of the components in the circuit may be defective** or worn. In most cases the relief valve is the problem.
3. Replace the valve cartridge and check the pressure again. If it cannot be adjusted to the proper level, **then either the motor or the pump is bad.**
4. Reconnect the hose and disconnect the hose at the inlet side of the motor. Again cap the hose, and very slowly engage the tractor PTO and read the pressure setting on the gauge. If the reading is OK, **the pump is good and the motor is excessively worn or defective.**
5. If the pressure is low **the pump section is excessively worn or defective.** In past history, the pump is seldom bad.

It is possible that contaminated oil, or oil at an extremely low level, may have caused the problem, so before you run the harvester again, please check it and replace the oil filter as well as the oil if necessary.

REAR CARRIER WHEEL RETURN TO STRAIGHT:

Rear harvester steering on the harvester can be either one-way or two-way steering. When two-way steering is desired, the return to straight option is recommended. A simple double rod cylinder control is operated through the front valve blank by two switches on the switch box in the tractor.

Connect the hoses furnished from the front valve bank tubes to the cylinder. Note: The hoses can also be connected directly to one of the tractor outlets if preferred and the tractor has the outlets available, but the required hoses will have to be furnished by the customer. If this is done, two valve banks on the harvester will not be required.

For correct operation, the cylinder must have the outside clevis rod fully extended and the inside clevis rod fully compressed when the carrier wheels are straight. One clevis is adjustable for making fine alignment adjustments. See illustration below.

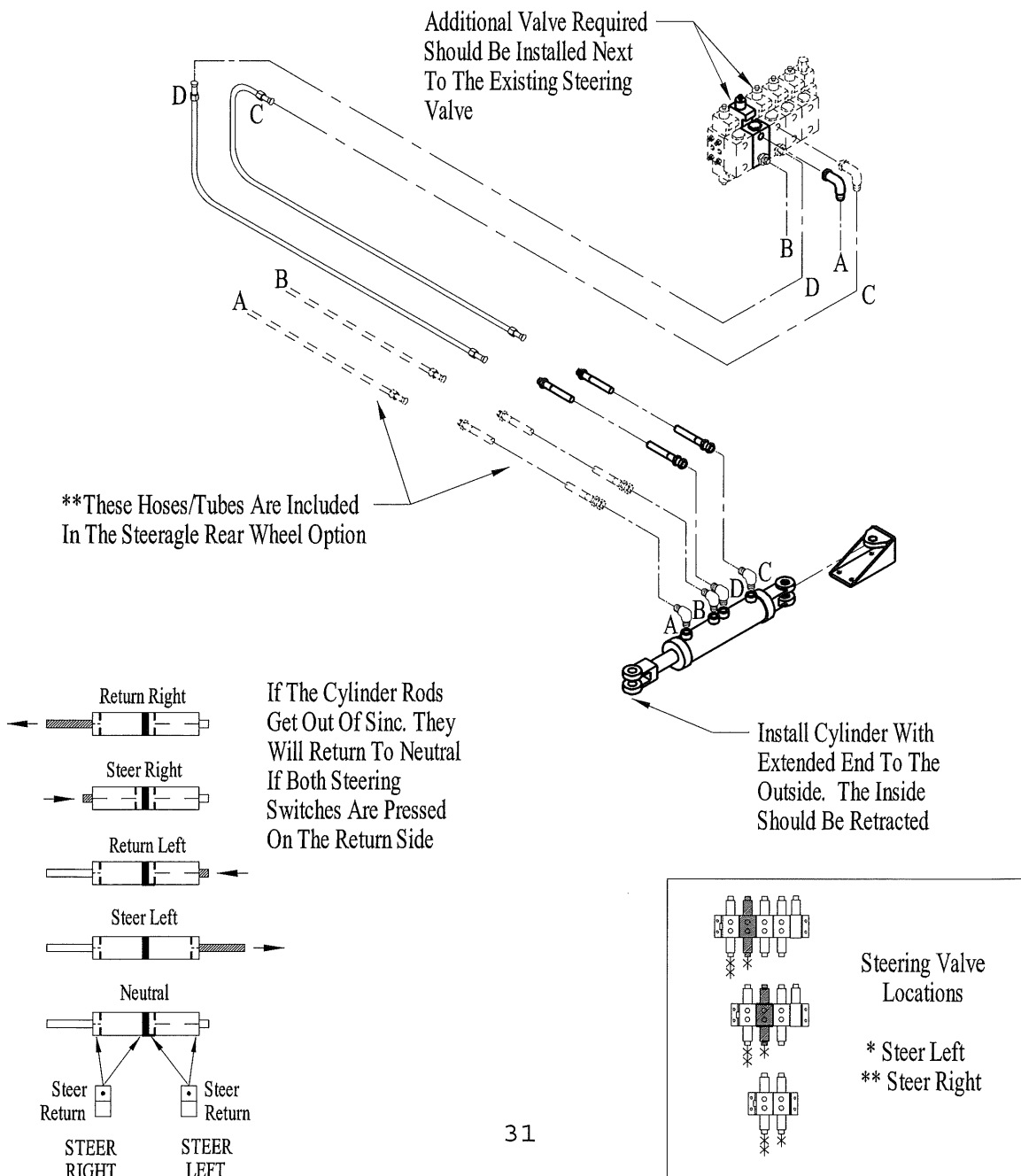

FIELD ADJUSTMENTS

Tractor PTO, RPM and Horsepower Requirements:

It is important that our customers understand that the shaft speeds of the harvester (that has been determined to be correct for the best harvesting operation) requires the tractor PTO to run at a full 1000 RPM or what is considered tractor "PTO speed." If the PTO is not operated at 1000 RPM, beet spillage in front of the grab rolls, potential harvester plugging, and excessive power consumption may occur.

It is also important to understand that if the tractor is underpowered and engine RPM is allowed to drop, resulting in slower PTO speed, the same problems may occur. The recommended minimum PTO horsepower for the 6-Row Harvesters is 150 HP minimum and the 8-Row Harvesters is 180 HP minimum.

Lifter Wheel Pinch Point Width and Digging Depth:

As assembled at the factory, the lifter wheel pinch point will be approximately 1¾" with one pair of wheel spacers in each wheel. This spacing with a digging depth of approximately 3½ inches is a good average setting to lift beets with a sufficient amount of soil to keep tail breakage and other beet damage to a minimum.

If possible, a minimum row speed of 4-5 miles per hour should be maintained for best root recovery and minimum spillage on the ground.

Ground conditions and texture vary greatly, and as a result these settings may have to be changed or set differently to obtain optimum performance of the harvester. If the beet tonnage exceeds 25 tons per acre or if the average beets exceed 6" in diameter, extra lifter wheel spacers may have to be installed to keep from breaking tails. If the ground is "**heavy gumbo**" and/or the average beets are less than 6 inches in diameter, lifter wheel spacers may be removed and the digging depth reduced. This will also greatly reduce the amount of mud being lifted into the machine. Refer to illustration Figure 8, page 17.

Place an appropriate amount of stroke control spacers in the lift cylinders to assure consistent digging depth. Place an equal amount of spacers in each cylinder to ensure even digging depth.

The illustration below shows how the band of dirt being lifted can change as pinch point widths differ. In general, the wider the pinch point is, the deeper the digging depth has to be and the more dirt will be lifted.

Paddle Shaft Height Adjustment:

The factory setting of the paddle shaft (approximately 3/4 inch clearance between the 3" square tubing corners and the lifter wheels) will operate effectively in most conditions. However, **in some conditions like heavy mud, very small beets, very large beets, slower or faster ground speed, changes may have to be made.** See the following chart for easy reference on change recommendations.

If the optional rock protection struts are used, **the paddle shaft should be raised so the lifter wheels don't hit the shaft tube when they flex.** Rubber paddle extensions should also be installed when flexible rock struts are used to make up for the raised position of the shaft. Refer to page 20.

The outside paddle shaft bearings are mounted on adjustable bearing plates, which are simple to raise up or down. The drive chain on the left side may have to be lengthened or adjusted as the shaft position changes.

PADDLE SHAFT HEIGHT / SPEED ADJUSTMENT CHECK								
	SPEED	SPEED	TONS	TONS	SIZE	SIZE	MUD	ROCKS
	-3 MPH	+5 MPH	+35	-20	-5"	+8"		
PADDLE HEIGHT	LOWER	-----	RAISE	LOWER	LOWER	RAISE	LOWER	RAISE
PADDLE SPEED	RAISE	----	----	----	LOWER	RAISE	RAISE	----
RUBBER EXTENSIONS	----	----	NO	YES	YES	NO	YES	YES
**PLEASE NOTE THAT THE ABOVE INFORMATION IS INTENDED ONLY FOR POSSIBLE SOLUTIONS TO PROBLEMS AND NOT DEFINITE ANSWERS.								

Machine leveling:

It is important that the machine be level front to back when in digging position. See page 18.

Row finder Adjustment:

See Options Setup and Adjustment on Page 21.

Grab Roll Adjustments:

The grab roll bed plays the single largest part in the cleaning and potential damage of the beets during harvesting. As a result, **proper adjustment of the grab rolls is vitally important.** If trash and mud removal is not an issue, **keep the rolls adjusted so there is approximately 1/4" clearance between the spiral on the large grab roll and the smooth roll.** As trash and mud removal become more important, the roll spacing should be widened. **Important: As the spacing**

gets wider, potential damage to beets and beet loss gets greater, and tractor power requirements become greater. Therefore, while making adjustments, move the smooth roll in small increments until the desired position is obtained. For severe "gumbo" condition, an optional mud flap kit is available to keep the beets on the grab roll longer.

Please note: When beet tops freeze and become ropey and tough, it is important that the beets are properly topped because the harvester "will not" remove the top and potential plugging problems may occur. If this condition exists, keep the grab roll spacing closer. See Figure 14. for adjustment explanation with the standard spring cushion as well as the rock protection spring.

The spacing should be rechecked at the beginning of each season to verify that the setting is OK for the initial ground conditions. Be sure to readjust if necessary through the season as the conditions change.

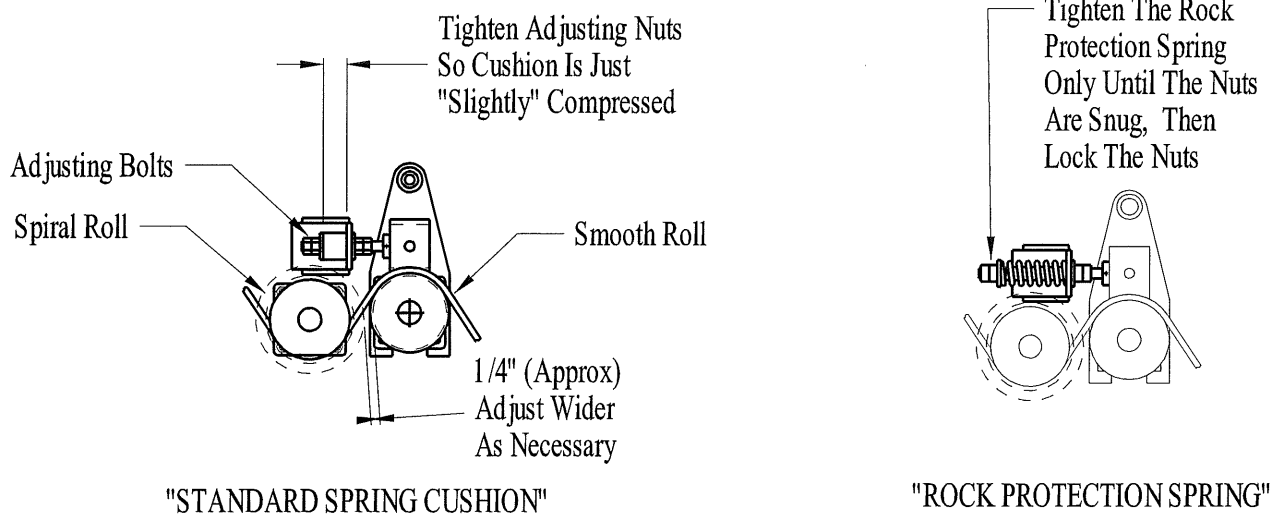

FIGURE 14

Rear Elevator:

The speed of the rear elevator draper chains, can be set to be in a "scrub" mode in extreme mud and heavy ground conditions. The most effective method found so far to accomplish this is to slow down the outside chain by replacing the existing 36-tooth sprocket with a 45-tooth sprocket. See Figure 15.

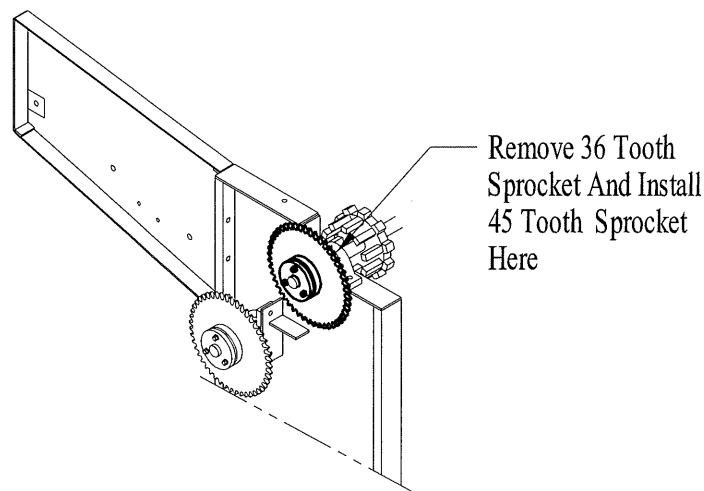

FIGURE 15

Rear Elevator Continued:

The **hugger arm springs** on the rear elevator can be adjusted in **some conditions** to help increase the cleaning of the beets. If the tension on the lower two springs is maintained properly, the two top springs can be loosened which will create more of a tumbling action in the beets. Start with adjusting the top spring only. **Only Attempt this if conditions are severe enough that the other adjustments aren't effective enough.** In higher tonnage or very large beets it is usually best to keep tension on all springs or the beets may stop moving entirely and jam in the elevator. The adjustable stops for the spring arms can also be adjusted to allow some increase in tumbling action in the beets (see page #15).

Beet Delivery From the Grab Rolls to the Rear Elevator:

It is **“CRITICAL”** that the grab roll spirals not be allowed to wear extensively. It has been proven that, especially in muddy conditions or in terrain that has hills, if the spirals get worn the beets will not feed properly into the elevator and may require the ground speed to be reduced and may eventually cause the beets to pile up and jam on the grab rolls.

The spirals have been hard surfaced by the factory, however you should check the spirals regularly through the season, and **if more than 1/8" of the top is worn off the spirals should be built up again with hard surfacing rod.**

Loss of Small Beets:

If this is occurring, it can usually be eliminated or greatly reduced by doing or checking the following:

1. Reduce the spacing between the grab rolls.
2. Check the spacing between the elevator draper chain and the last spiraled grab roll. If the spacing is more than 2" adjust it closer by moving the rollers forward. See figure 16.

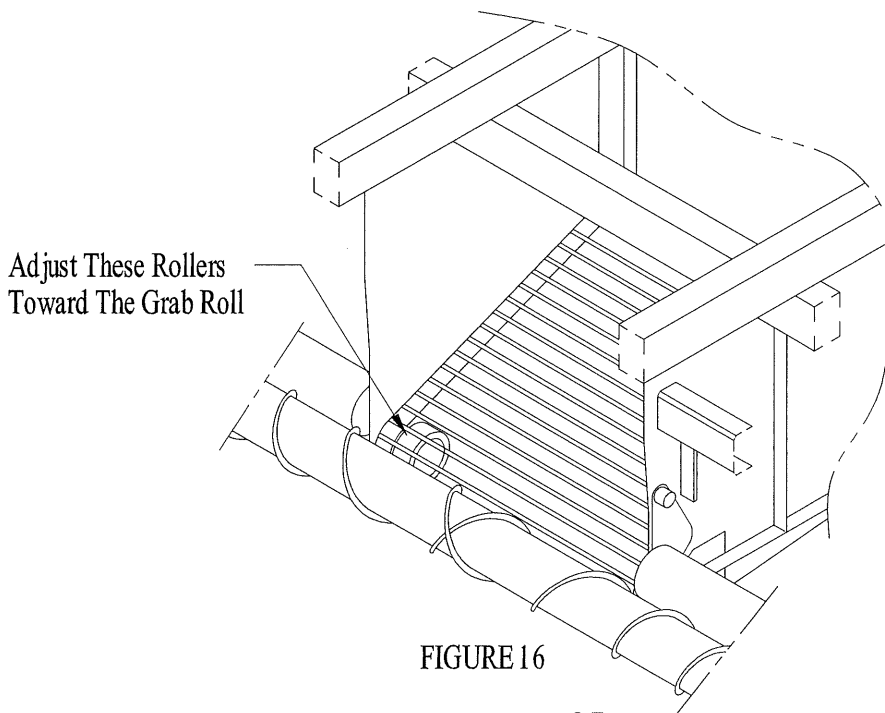

FIGURE 16

MAINTENANCE SCHEDULE

Item	Service	4 Hr	Daily	Weekly	Yearly
1	Gear Box Oil Level			X	X
2	Lifter Wheel bearing Lubrication			X	
3	Roller Bearing Lubrication**				
4	Pillow Block & Flanged Bearing Lubrication**		X	X	
5	Carrier Wheel Bearing Re-pack				X
6	Roller Chain Lubrication		X		
7	Tongue Bushing Lubrication		X		
8	Elevator Drive & Chain Tightener Lubrication		X		
9	Discharge Boom Pivot Lubrication		X		
10	Steering Strut Lubrication		X		
11	PTO Drive Line & Other U-Joint Lubrication		X		
12	Grab Roll Hanger Bracket Lubrication			X	
13	Draper Chain Adjustment / Check		X		
14	Roller Chain Adjustment / Check	X			
15	Grab Roll Drive Belt Tightener Adjustments	X			
16	Elevator Hugger Spring Tension**				
17	Bolt & Nut Tightness Check		X		
18	Row Finder Pivot Shaft		X		

**Refer to corresponding item in maintenance schedule explanation

MAINTENANCE SCHEDULE EXPLANATION

- Item 1: To check the oil level in the main gearbox, remove the pipe plug in the back or side of the housing. The oil level should be at the level of the hole. If it is not, fill through the top hole until oil starts to run out. Use a good grade of 90-weight gear oil. Check for oil leaks daily and replace the oil on a yearly basis.
- Item 2: Check to be sure the lifter wheel hubs are fully packed with grease before initial use of the harvester. Apply grease with a gun until grease is visible coming out of the inner seal. The hubs should be greased on a weekly basis and re-packed with new grease at the beginning or end of each season.

- Item 3: The bearings in the rollers in the elevator, tank, and discharge conveyor are sealed and need not be greased.
- Item 4: The Pillow Block and Flanged bearing units are factory pre-lubricated and, therefore, do not require supplemental grease before service life begins. Re-lubrication, when administered correctly, can increase the life of a bearing substantially. **Bearing manufacturers recommend that all these bearings be greased daily to weekly**, considering the environmental condition that these harvesters are exposed to. **NOTE: Over lubrication is a major cause of bearing failures. Please re-lubricate conservatively.** When selecting a bearing lubricant, use any lithium-based NLGI #2 grease.
- Item 5: Carrier wheel bearings should be re-packed and the seals replaced at the beginning of each season.
- Item 6: Apply oil to all roller chains daily during operation.
- Item 7: There are two areas of lubrication on the front tongue. One is at the pivot near the harvester (heavy duty swivel hitch) and one is at the pivot near the tractor. Grease these two areas daily.
- Item 8: The chain tightener arms in the elevator have grease points at each end. Grease these daily. Grease each spring loaded roller chain tightener arm daily.
- Item 9: There are two lubrication points at the outside ends of the discharge boom pivot tube. Grease daily.
- Item 10: There are two grease points on each rear steering strut. Grease these daily.
- Item 11: **The PTO driveline slip joint must be greased thoroughly prior to initial use** and at the beginning of each season. Pull the driveline apart and apply grease by hand on the male shaft then reassemble. During operation, this slide as well as the U-joints on the driveline should be greased daily. The other U-joints mounted on the main gearbox (there are three) should be greased daily.
- Item 12: Grease the hanger bracket pivot points at each end of the smooth grab rolls on a weekly basis.
- Item 13: The lock nuts in the splice connection of the belted chain in the rear elevator and hopper should be checked daily to be sure they are snug and secure. If any need replacing, **Do Not Replace Them With Elastic Stop Nuts.** If they are used, failure may occur causing possible damage to the belted chain and/or machine.
- Item 14: The roller chain drives should be checked for tightness and sprocket alignment. Excessive slack in the chain that is not spring loaded will cause premature wear in the chain and sprockets. Also check spring loaded drives for excessive slack.. Remove links as necessary.

- Item 15: Initially the idler arm tightener should be adjusted so the spring is compressed so that there is approximately 1/16" clearance between the coils. (Refer to page 19, Figure 11)
This compressed distance should be maintained. Once the drive belts have been "**run in**", the belt stretch should be minimal but "**Check often**" to prevent belt slippage or breakage.
- Item 16: The required tension of the elevator hugger springs may vary according to ground wetness conditions and/or beet size variation and tonnage. If excessive roll back is noticed in the elevator, the springs should be tightened. The bottom tightener arm springs usually play a larger part in solving this problem. In many cases, adjustments made here may be the only ones required. Be careful not to over tighten the upper springs because this can also hinder the beet flow in some conditions. (Refer to page 15, Figure 6 & page 35.)
- Item 17: PARMA COMPANY employees are concerned with the quality of the product they produce. Sometimes, however, improperly tightened bolts may occur. Also, quite often, vibration during initial harvesting operation may cause bolts to loosen. If they are checked after the first few hours of operation and then periodically during the first season, potential problems can be eliminated.
- Item 18: Smooth operation of the Rowfinder is key to keeping the harvester directly on the row at all times. Grease the pivot shaft that the fins are connected to daily, and inspect the pivot to be sure the fins move freely, and there is no excess slop between the pivot shaft and the bushings in the frame.

TROUBLE SHOOTING

SYMPTOM	POSSIBLE CAUSE	POSSIBLE SOLUTION
<p>Harvester not staying on row.</p>	<p>Row finder not operating or adjusted correctly.</p> <p>Rear steering not set properly and harvester is not tracking straight, or rear wheels are not set on correct spacing.</p> <p>Harvesting over a guess row.</p> <p>With some tractor tire spacings, the tongue is offset to the right hand side. The tongue should be straight rather than set on an angle.</p> <p>Lifter wheels not set at correct row spacing.</p>	<p>See row finder adjustments pg. 21 & 22.</p> <p>Straighten steering by adjusting cylinder clevis. If return to straight option is being used, refer to pg. 31 for adjustment. Refer to pg. 20 for row settings, & pg. 18 for wheel tracking.</p> <p>Recount rows and start again.</p> <p>Check and reset if necessary. See page 20 for correct settings.</p> <p>See Lifter Wheel Spacing Chart on pg. 20.</p>
<p>Beet tails are breaking and staying in ground.</p>	<p>Digging depth may be too shallow and/or pinch point width may be too narrow.</p> <p>Refer to "Harvester not staying on row"</p> <p>Lifter wheel spacing not correct</p> <p>Ground is dry and hard.</p> <p>Rear tractor tires too wide, and the beets are being moved.</p>	<p>Change digging depth or add spacers to lifter wheels to widen pinch point or both.</p> <p>Refer to pages 17 & 32.</p> <p>See page 20.</p> <p>Increase digging depth. Irrigate if possible before harvesting</p> <p>Consult your dealer. Change Tires</p>

TROUBLE SHOOTING CONTINUED

SYMPTOM	POSSIBLE CAUSE	POSSIBLE SOLUTION
<p>Beet tails being lifted, but beets are being broken in or dropped through harvester.</p>	<p>Paddle shaft too high for small beets.</p>	<p>Lower paddle shaft. Install optional rubber paddle extensions. Refer to page 33.</p>
	<p>Small beets falling through lifter wheel spokes.</p>	<p>Increase row speed to 4-5 MPH. Increase digging depth.</p>
	<p>Beets rolling back over lifter wheel hubs.</p>	<p>Check PTO speed (should be 1000 RPM). Decrease row speed to 4-5 MPH. Lower paddle shaft. Install optional rubber paddle extensions.</p>
	<p>Grab roll spacing too wide and beets being broken or pulled through rolls.</p>	<p>Adjust grab roll spacing. See pages 33-34 for instructions.</p>
<p>Solenoid valve bank not operating correctly.</p>	<p>Oil flow from tractor too high</p>	<p>Lower the flow to 21 G.P.M. maximum</p>
	<p>Tractor hydraulics (open / closed) do not match valve bank or row finder setting.</p>	<p>Refer to pages 23-27 for instructions.</p>
	<p>The pressure/ tank ports on the valve bank do not match the pressure/tank ports on the tractor.</p>	<p>Switch the hydraulic lines. "P" & "T" ports are marked on the valve bank.</p>
	<p>Contamination exists in one or more valves or a valve is defective or damaged.</p>	<p>Remove and clean or replace spool in valve, or replace valve. Refer to pages 25 & 26 for instruction.</p>
	<p>Wiring hookup wrong.</p>	<p>Refer to schematic page 42.</p>

TROUBLE SHOOTING CONTINUED

SYMPTOM	POSSIBLE CAUSE	POSSIBLE SOLUTION
<p>Damage to harvester or jamming occurring due to rocks or stones in field.</p>	<p>Rock protection option for lifter wheels, struts, and grab rolls not installed. If rock protection springs are installed on the grab rolls, and problems still occur, adjust the grab rolls closer together.</p>	<p>See your local dealer for available options. <u>Please Be Aware that the available options do not eliminate all problems or damages encountered with harvesting in rocky conditions. They only minimize the problems or damage.</u></p>
<p>Excess dirt and or tops being loaded into truck.</p>	<p>Digging depth too deep.</p> <p>Grab roll spacing too close.</p> <p>Rear elevator draper chain speeds can be changed to compensate for severe mud conditions.</p> <p>Beet tops not being removed and/or swept from top of row adequately.</p> <p>Grab roll mud flaps not positioned correctly.</p>	<p>Raise machine. If beets start breaking when this happens, pinch point width can be increased to possibly stop the breakage.</p> <p>Adjust grab roll spacing. See pg. 33-34 for instructions.</p> <p>See pg. 34 for changes to obtain "Scrubbing" effect.</p> <p>This is a common problem with many harvesting operations and often overlooked as a cause for excessive tear and/ or plugging problems.</p> <p>Readjust the grab roll mud flaps further forward to keep the beets on the grab rolls longer.</p>

SWITCH BOX 15 POSITION CONNECTOR PIN NUMBERS/COLORS

PIN#	COLOR	FUNCTION	PIN#	COLOR	FUNCTION
1	Orange	Not Used	9	Black/Red	Steer Right
2	Orange/Black	Not Used	10	Red	Steer Right
3	Green	Not Used	11	Red/Black	Unloader Valve
4	Brown/Black	Not Used	12	Orange/Red	Over Ride
5	Blue	Boom Up	13	Yellow/Black	Over Ride
6	Blue/Black	Boom Down	14	Black/White	Not Used
7	Blue/Red	Steer Left	15	Yellow	Ground
8	Black	Steer Left			

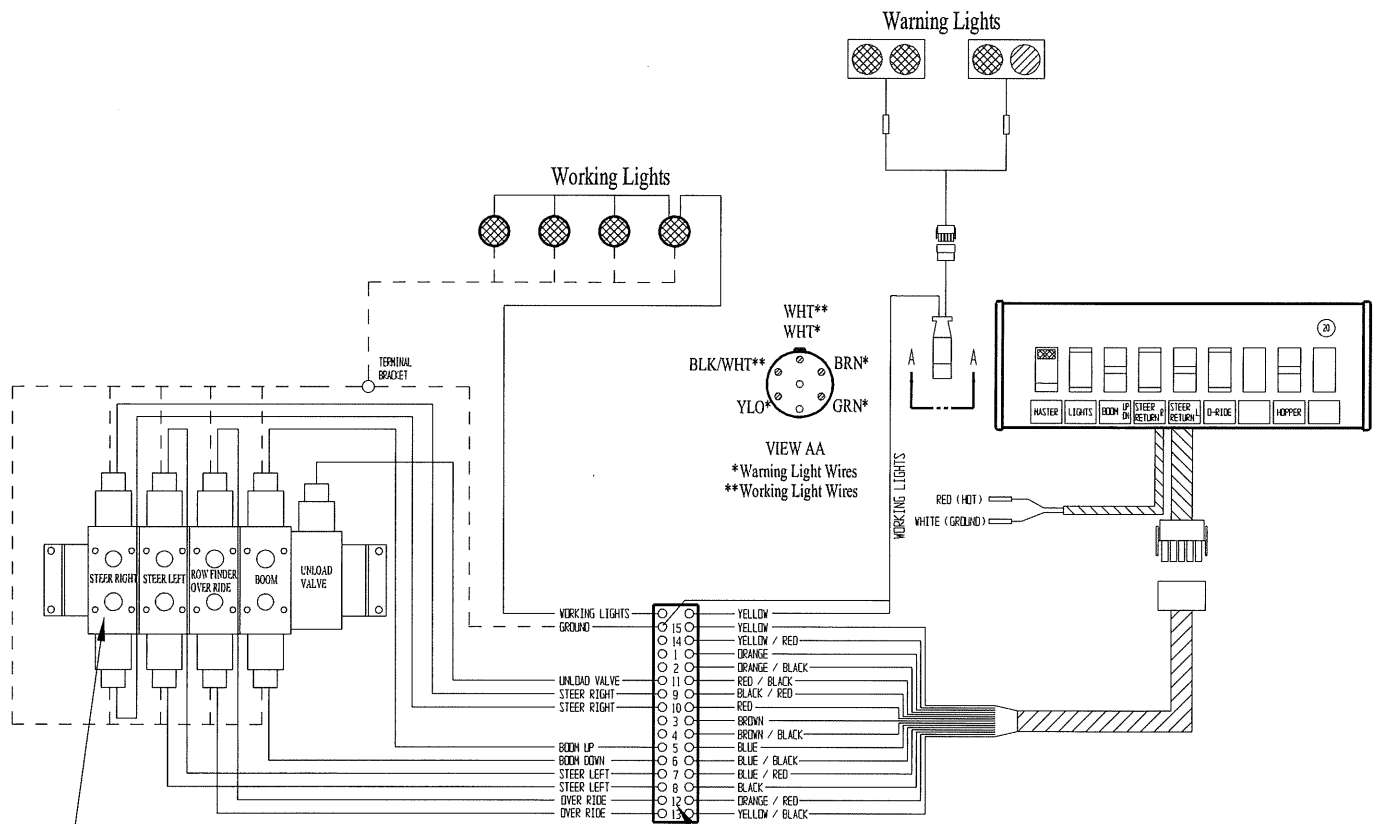

Note: When The RETURN To Straight Steering Is Not Used, This Valve Is Eliminated.

These Numbers Should Correspond With The Pin Number Functions In The Above Chart. The Colors May Vary.

ELECTRICAL DIAGRAM

PARMA[®]

Model 12228
Beet Harvester
PARTS BOOK

Manual Number 04192016-12228

PARMA COMPANY

P.O. BOX 190
PARMA, IDAHO 83660
PHONE (208) 722-5116 FAX (208) 722-6012
Website: www.parmacompany.com

INDEX

DECAL GROUP	40
GEAR BOX ASSEMBLY	43
GRAB ROLL BED ASSEMBLY	18
GRAB ROLL BELT DRIVE COMPONENTS	16
GRAB ROLL HANGERS & DOORS	14
GRAB ROLL MUD FLAPS	13
GRAB ROLL ROCK SPRING KIT	12
HOPPER MOUNTING & ATTACHMENTS	20
HOPPER ASSEMBLY	22
HYDRAULIC SCHEMATIC (CYLINDERS)	32
HYDRAULIC SCHEMATIC (MOTOR DRIVES, TRACTOR DRIVEN)	34
LIFTER WHEEL ROCK STRUT ASSEMBLY	8
LIFTER WHEEL STANDARD STRUT ASSEMBLY	6
LIGHTING KITS	38
MAIN DRIVE GROUP	2
PADDLE & BAFFLE GROUP, 12228	10
PLATFORM ASSEMBLY	41
PTO DRIVE LINE ASSEMBLY, STANDARD	3
PTO DRIVE LINE ASSEMBLY, CONSTANT VELOCITY	4
REAR ELEVATOR ASSEMBLY	24
REAR ELEVATOR TOP ASSEMBLY	25
RETURN TO STRAIGHT, 2-WAY STEERING	30
ROLLERS AND IDLER SPROCKETS	26
ROW FINDER ASSEMBLY	37
ROW FINDER HYDRAULICS	39
SLIP CLUTCH ASSEMBLY	13
STEERABLE REAR WHEEL ASSEMBLY	28
TONGUE ASSEMBLY	1
VALVE BANK ASSEMBLY	31
WIRING SCHEMATIC	42

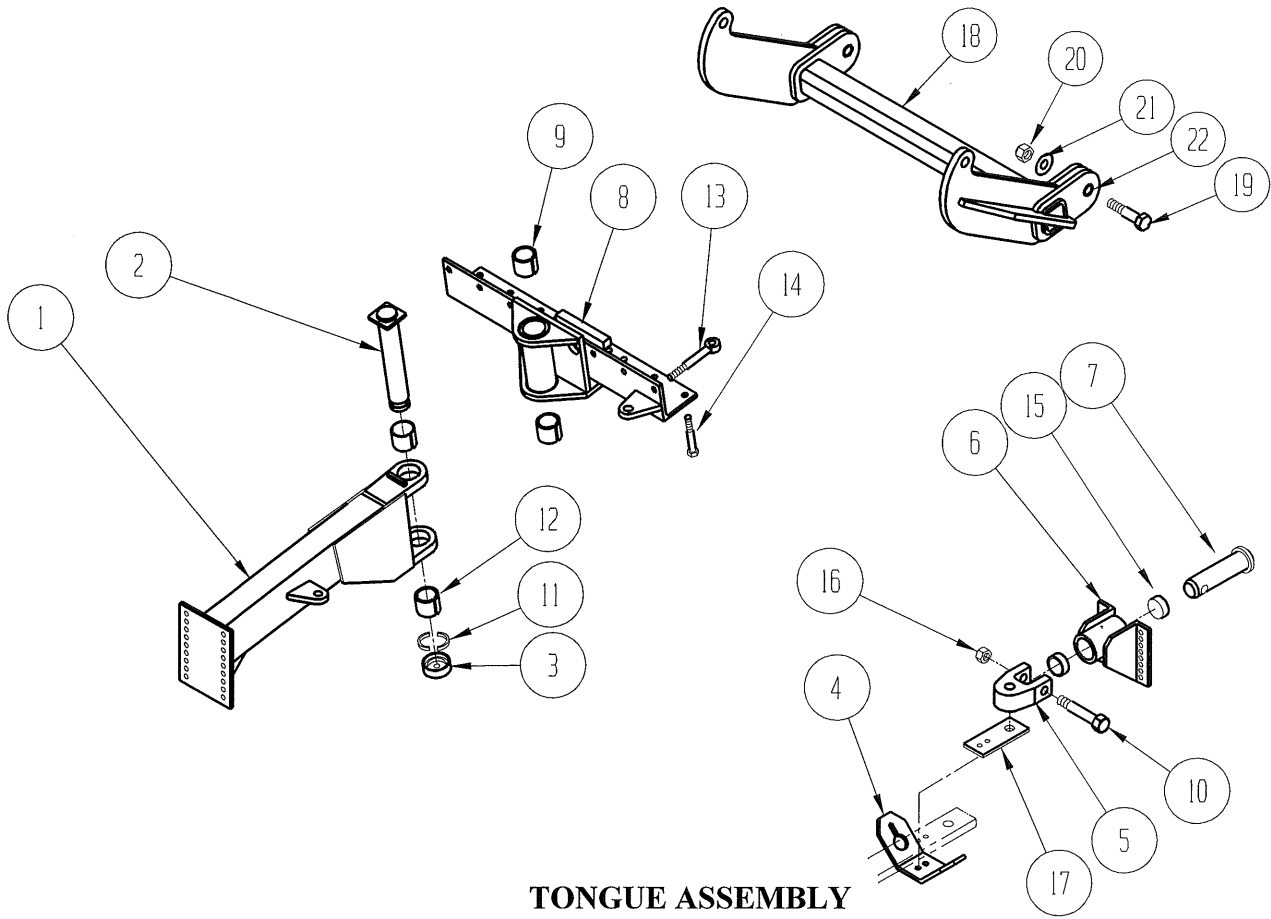

TONGUE ASSEMBLY

ITEM NO.	QUANTITY	PART NO.	DESCRIPTION
1	1	268582	Tongue (Less Bushing)
2	1	268587	Tongue Pin
3	1	268590	End Cap
4	1	264659	Draw Bar Support
5	1	721072	Hitch Clevis
6	1	721074	Tongue Pivot w/Bushings
7	1	721073	Pivot Pin
8	1	268592	Tongue Mounting w/ Bushings
9	2	721070	Bushing
10	1	721077.12	Hitch Clevis Bolt
11	1	268591	Split Collar
12	2	268589	Bushing
13	6	997903	Eye Bolt 3/4-10 x 6"
14	6	-----	Hex Cap Screw 3/4-10 x 6
15	2	721070	Bushing
16	1	-----	Hex Lock Nut, 1 1/8-7 UNC
17	1	264658	Spacer Plate
18	1	268545	Lift Bracket
19	2	-----	Hex Bolt, 1 1/4 x 5 1/2 Grade 8
20	2	-----	Lock Nut, 1 1/4
21	4	-----	Flat Washer, 1 1/4
22	4	522387	Bushing, 1 1/4 ID, 1 5/8" OD
23	1	268795	Drawbar Shim Kit

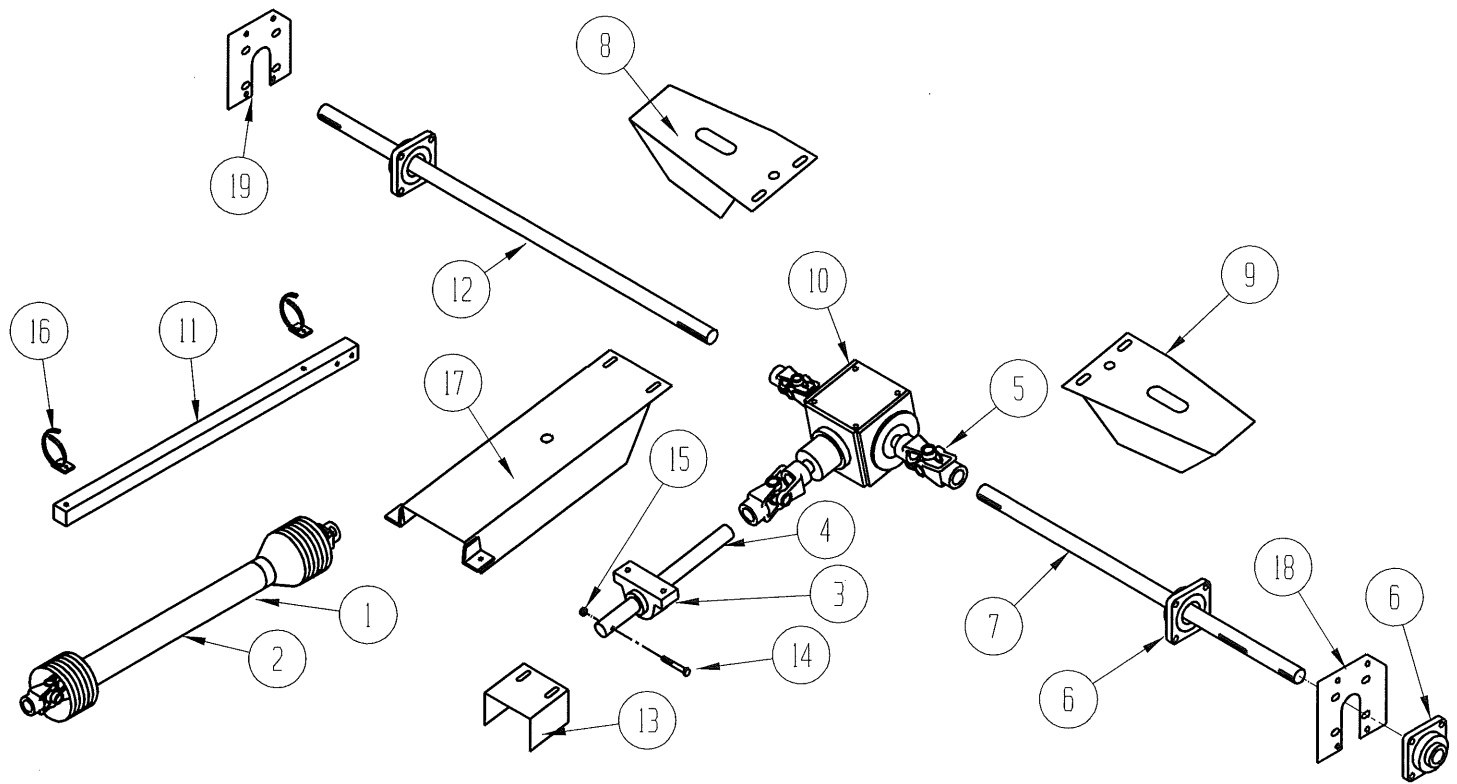

MAIN DRIVE GROUP

ITEM NO.	QTY	PART NO. 12228	DESCRIPTION
1	1	----- 991040	PTO Drive Line Asm 1 3/8-21
	1	----- 991096	PTO Drive Line Asm 1 3/4-20 (Bondioli, See Breakdown Pg.3)
2	1	----- 991042	C.V. PTO Drive Line 1 3/8-21
	1	----- 991043	C.V. PTO Drive Line 1 3/4-20 (Bondioli, See Breakdown Pg.4)
3	1	----- 267470	Bearing, 1 3/4 Spherical Roller
4	1	----- 267541	PTO Drive Shaft
5	3	991074	Yoke, 1 3/4 Bore-6-Spline
		990824	Cross Kit, #6
		991063	Yoke, 1 3/4" 6-Spline
		991089	Yoke, 1 3/4 Smooth
6	4	980822	4-Bolt Flange Bearing 1 3/4
7	1	----- 268570	Cross Drive Shaft, LH
8	1	----- 230077	U-Joint Cover, RH
9	1	----- 230078	U-Joint Cover, LH
10	1	----- 267171	Gear Box 1.93:1(see page 46)
11	1	----- 266556	Hose Holder
12	1	----- 268570	Cross Drive Shaft, RH
13	1	----- 266368	Cover, Gear Box Shaft
14	1		Hex Cap Screw, 3/8 x 3 1/2, GRD 5
15	1		Lock Nut, 3/8
16	2	----- 265953	Hose Ring
17	1	----- 267540	PTO Shield
18	4	----- 267876	Bearing Plate

+

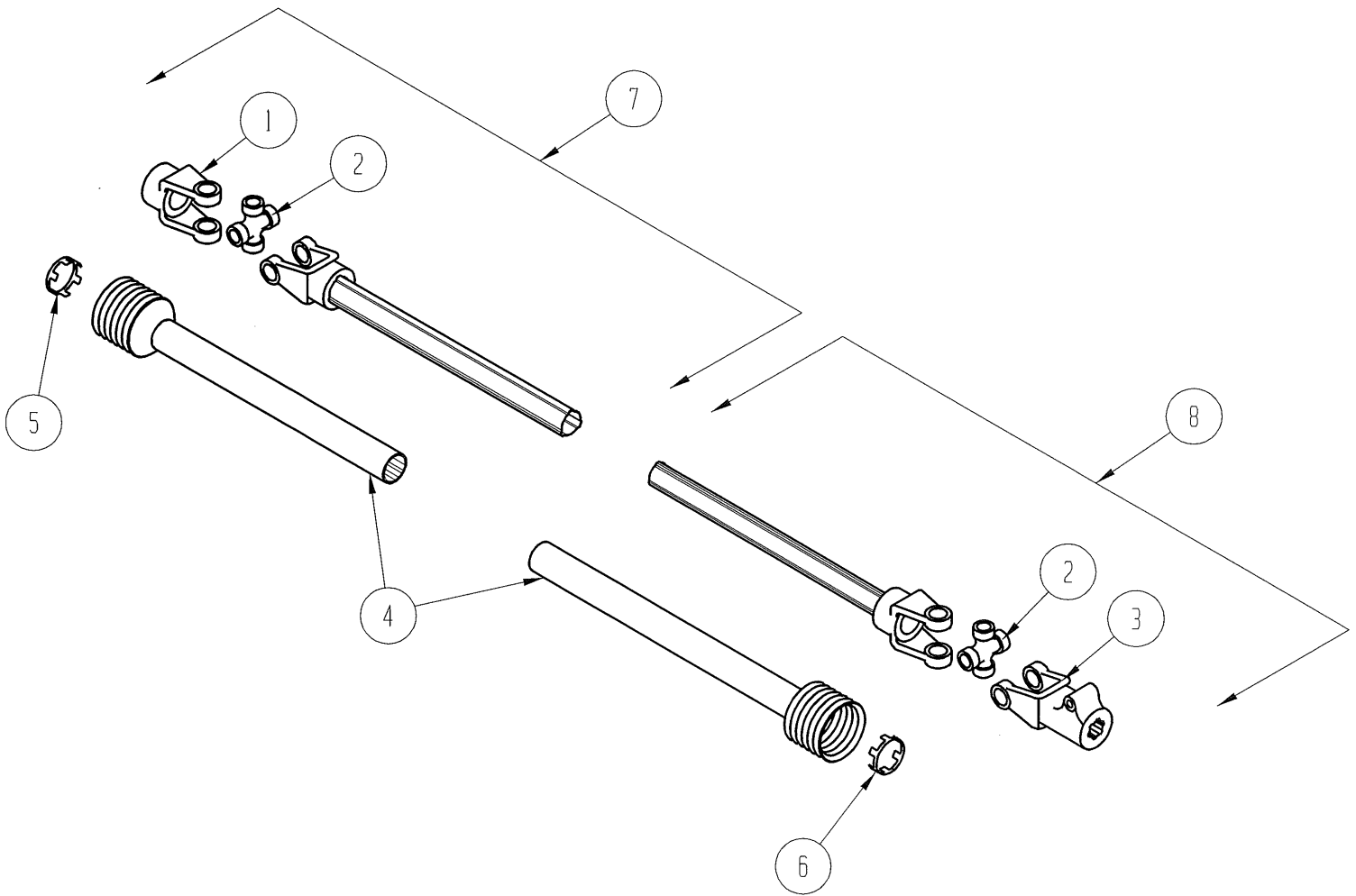

PTO DRIVE LINE ASSEMBLY

ITEM NO.	QUANTITY	PART NO.	DESCRIPTION
1	1	-----	Round Bore Yoke 1 3/4-3/8 KW
2	2	991111	Cross & Bearing Kit
3	1	-----	Q.D. Yoke, 1 3/8-21 Splined
4	1	-----	Q.D. Yoke, 1 3/4-20 Splined
4	1	991113	Drive Line Shield Assembly
5	1	991114	Bearing retainer, Inner Shield
6	1	991115	Bearing retainer, Outer Shield
7	1	-----	Drive Line Implement Half w/ Shield, 1 3/4"
8	1	-----	Drive Line Tractor Half w/ Shield, 1 3/4-20
	1	-----	Drive Line Tractor Half w/ Shield, 1 3/8-21

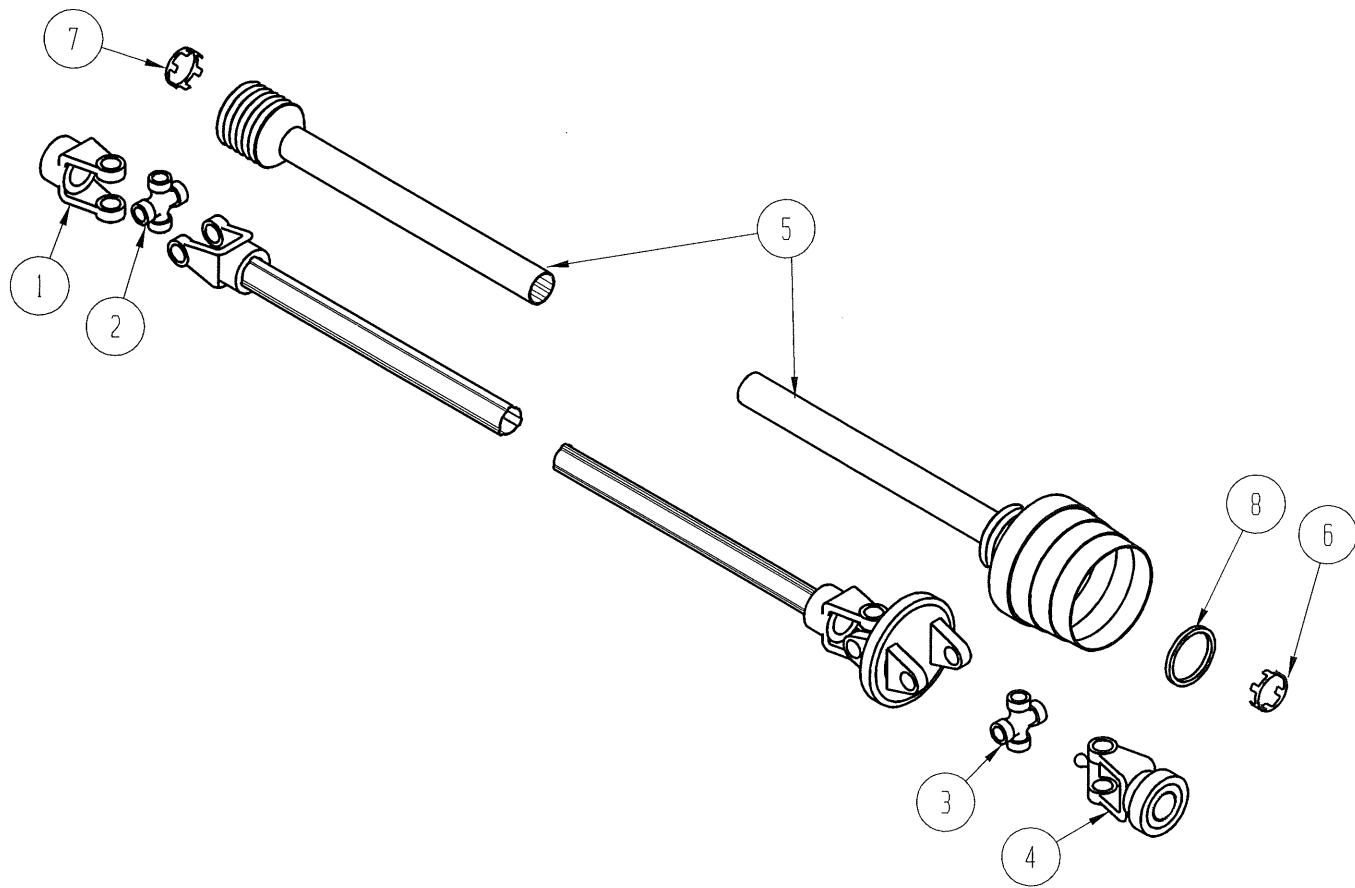

CONSTANT VELOCITY DRIVE LINE ASSEMBLY

ITEM NO.	QUANTITY	PART NO.	DESCRIPTION
1	1	991098	Yoke, 1 3/4- 3/8 KW
2	1	991100	Cross & Bearing Kit
3	1	991101	Cross & Bearing Kit
4	1	991102	QD Yoke, 1 3/8-21 Splined
		991107	QD Yoke, 1 3/4-20 Splined
5	1	991103	Drive Line Shield Assembly
6	1	991104	Bearing Retainer, Outer Shield
7	1	991105	Bearing Retainer, Inner Shield
8	1	991106	CV Cone Retainer

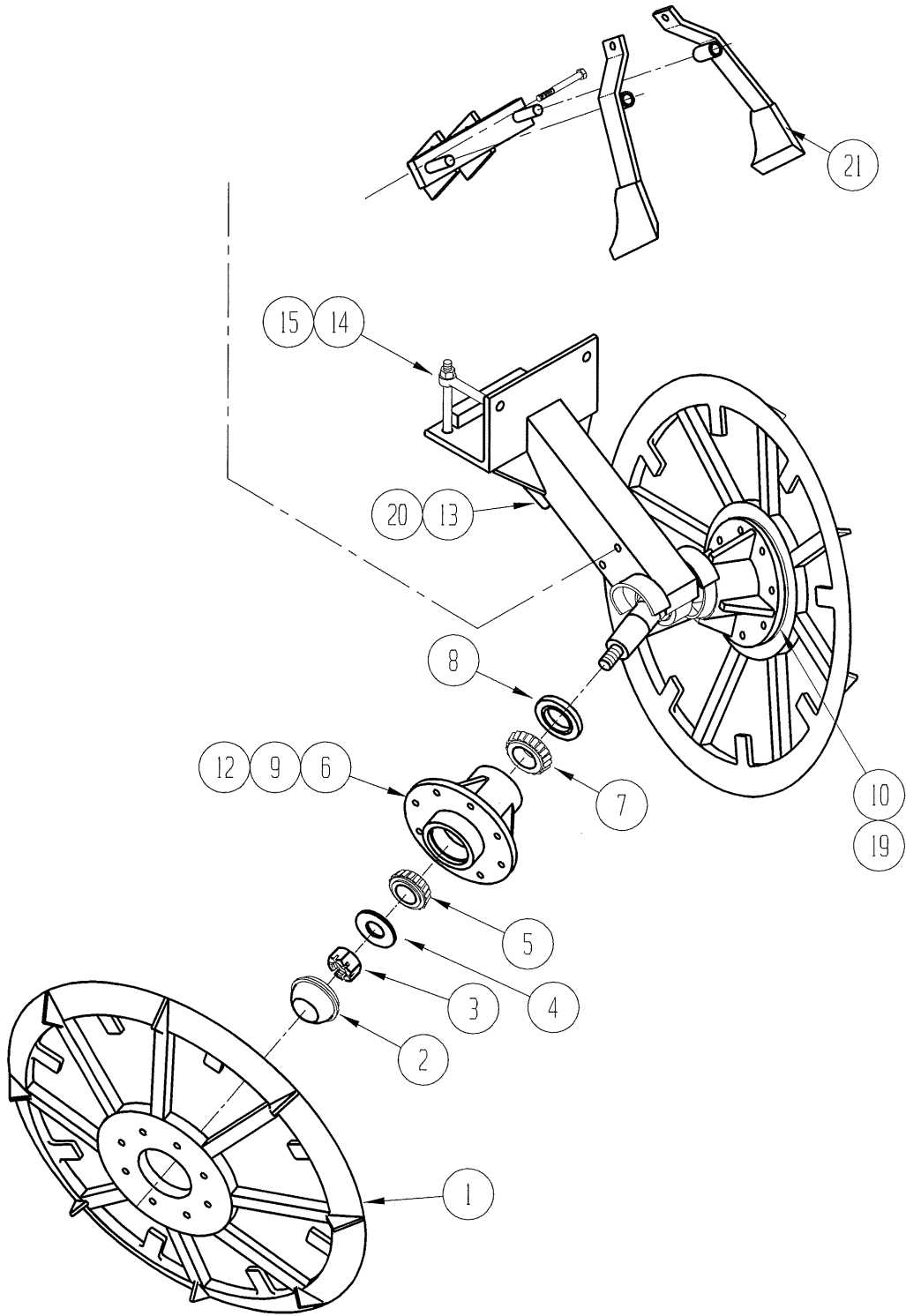

LIFTER WHEEL STANDARD STRUT ASSEMBLY

267500

ITEM NO.	QTY	PART NO.		DESCRIPTION
		WIDE	NARROW	
1	2	267939	267939	Lifter Wheel w/ Peg Fillers
2	2	999865	999865	Dust Cap
3	2	999002	999002	Slotted Nut 1 1/4-12 UNF
4	2	998139	998139	1 1/4 Flat Washer
5	2	990017	990017	Bearing Cone (Outer)
6	2	267941	267945	Hub Assembly (Includes Items #9 & #12)
7	2	990014	990014	Bearing Cone (Inner)
8	2	999837	999837	Seal
9	2	990015	990015	Bearing Cup (Inner)
10	4	999836	999836	Spacer, Single Half, 1/4"
11	2	266348	266348	Shim, 1/4"
12	2	990016	990016	Bearing Cup (Outer)
13	1	267503	267943	Lifter Wheel Strut & Spindle
	1	999841	265655	Replacement Spindle (Weld in)
14	2	264151	264151	3/4 x 8 Eye Bolt
15	2	-----	-----	Hex Bolt 3/4-10 UNC x 8
16	1	266485	266315	Scraper, LH
17	1	266486	266316	Scraper, RH
18	As Req'd	267222	267222	Shim, 1/8"
19	As Req'd	267173	267173	Spacer, Single Half, 1/8"
20	As Req'd	267501	267942	Wheel Strut Assembly w/ Bearings & Hubs
21	1	268022	268022	Scraper, LH (Optional Style)
	1	268023	268023	Scraper, RH (Optional Style)

NOTICE: The Above Lifter Wheel and Hub Assemblies use 1/2" bolts!

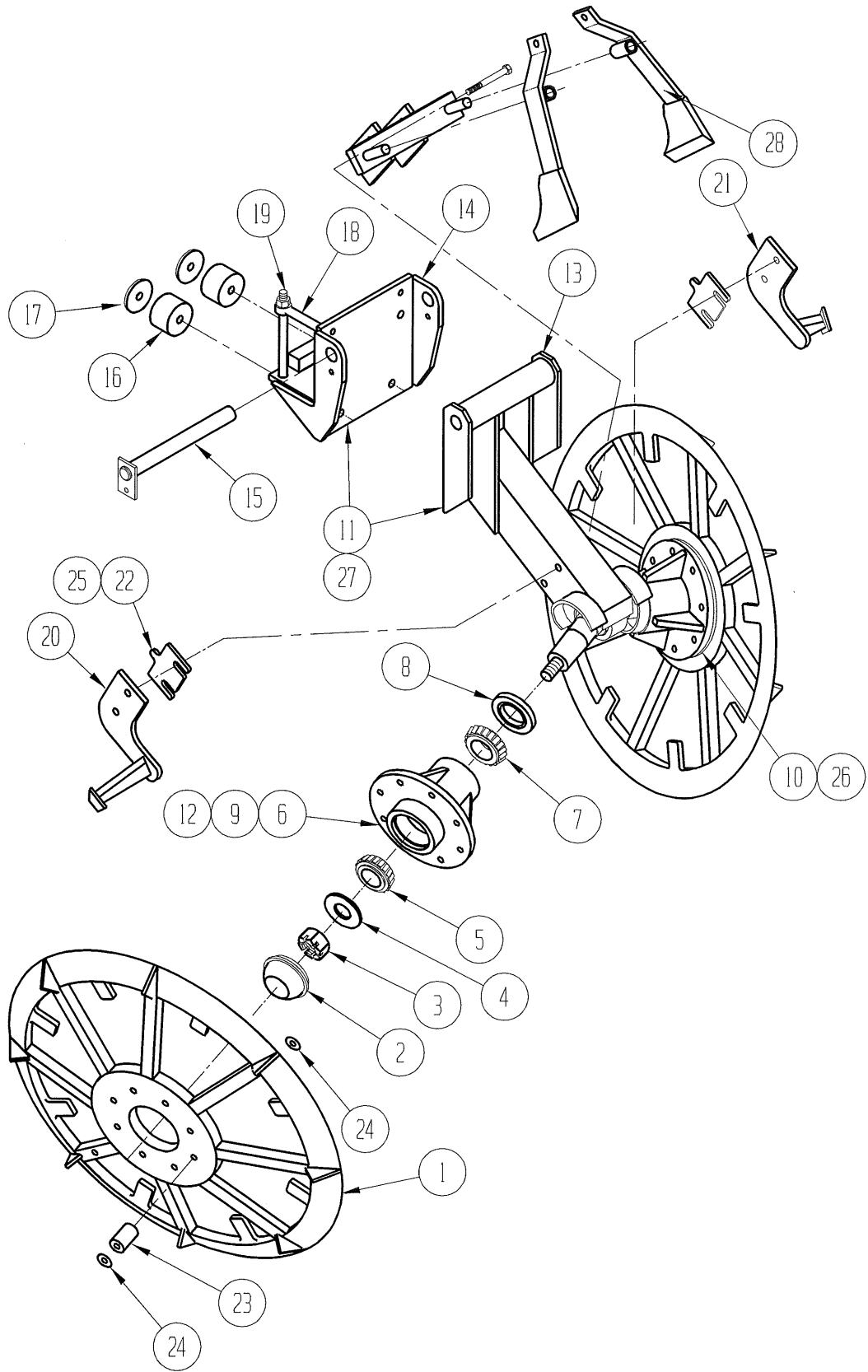

LIFTER WHEEL ROCK STRUT ASSEMBLY

268708

ITEM NO.	QTY	PART NO.		DESCRIPTION
		WIDE	NARROW	
1	2	267939	267939	Lifter Wheel w/ Peg Fillers
2	2	999865	999865	Dust Cap
3	2	999002	999002	Slotted Nut 1 1/4-12 UNF
4	2	998139	998139	1 1/4 Flat Washer
5	2	990017	990017	Bearing Cone (Outer)
6	2	267941	267945	Hub Assembly (Includes Items #9 & #12)
7	2	990014	990014	Bearing Cone (Inner)
8	2	999837	999837	Seal
9	2	990015	990015	Bearing Cup (Inner)
10	4	999836	999836	Spacer, Single Half, 1/4"
11	1	267731	267948	Strut & Mounting Asm (Includes Items #13,14,15,16, & #17)
12	2	990016	990016	Bearing Cup (Outer)
13	1	267769	267949	Lifter Wheel Strut & Spindle
	1	999841	265655	Replacement Spindle (Weld in)
14	1	267729	267729	Mounting Weldment
15	1	266430	266430	Pivot Pin
16	2	265134	265134	Spring Cushion
17	2	265135	265135	Spring Washer
18	2	264151	264151	3/4 x 8 Eye Bolt
19	2	-----	-----	Hex Bolt 3/4-10 UNC x 8
20	1	266485	266315	Scraper, LH
21	1	266486	266316	Scraper, RH
22	2	266348	266348	Shim, 1/4"
23	32	267986	267986	Urethane Cushion
24	32	267985	267985	Washer
25	As Req'd	267222	267222	Shim, 1/8"
26	As Req'd	267173	267173	Spacer, Single Half, 1/8"
27		267803	267947	Wheel Strut Assembly w/ Bearings & Hubs
28	1	266986		Scraper Assembly Top Mount

NOTICE: The Above Lifter Wheel, Hub Assemblies, and Cushions use 1/2" bolts!
 1/2 x 4 1/2 Grade 5

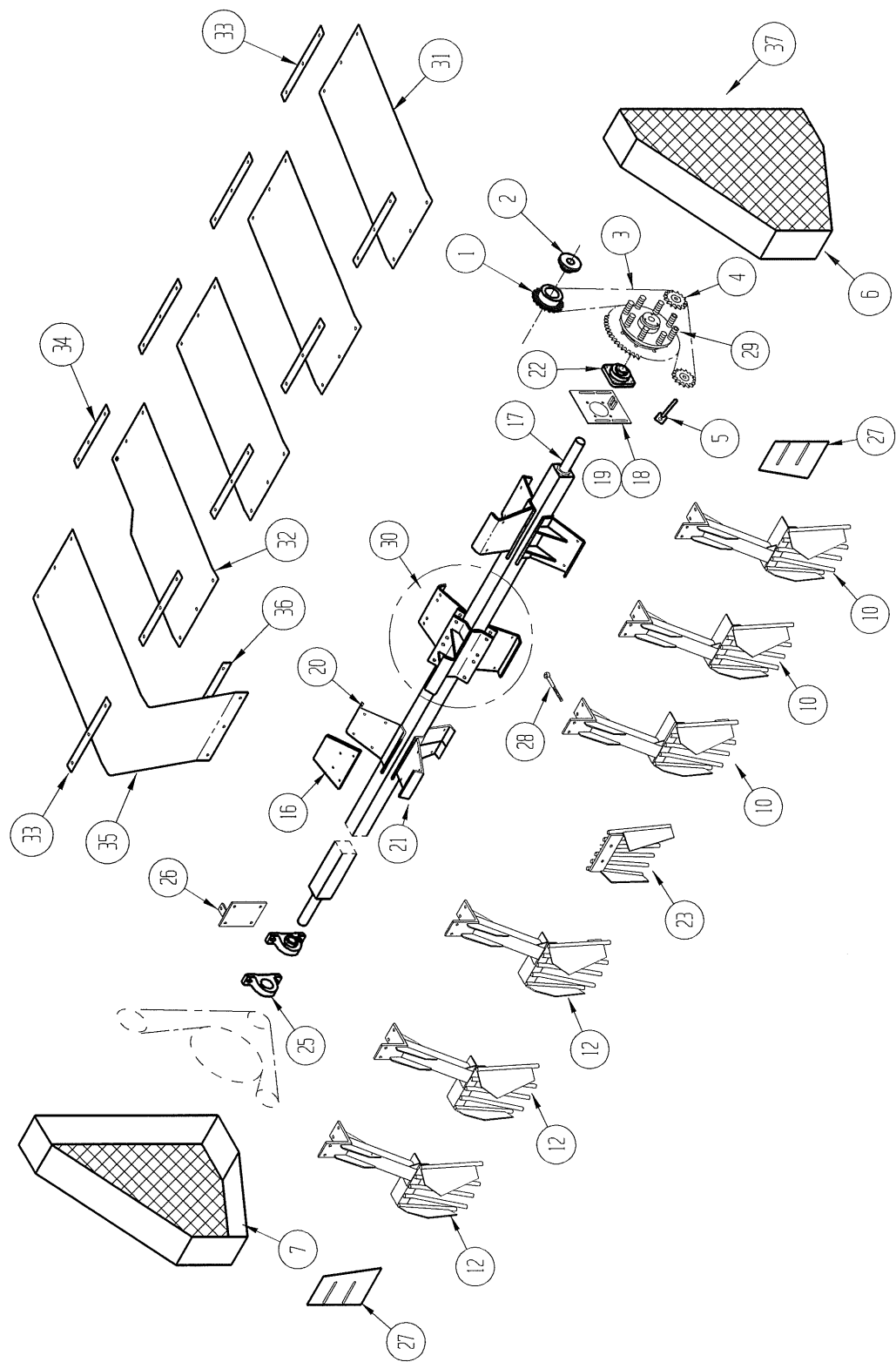

PADDLE & BAFFLE GROUP, MODEL 12228 SERIES

ITEM	QTY	PART NO.	DESCRIPTION
1	2	267212	Sprocket, H80P12
2	2	290357	Bushing, P1-1 3/4
3	96"/Side	980912	Roller Chain, RC80
	1 / Side	980927	Master Link, RC80
4	4	980751	Idler Sprocket, 12 Tooth
5	2	266998	Draw Bolt
6	1	267864	Drive Cover, LH
7	1	267865	Drive Cover, RH
8			
9	6	-----	Hex Bolt, 1/4 x 3, Double Nut
10	5	268330	Baffle Bracket, LH Offset
11			
12			
13	5	268332	Baffle Bracket, RH Offset
14			
15			
16	1/rw	268929	Rubber Backing Paddle
17	2	268552	Paddle Shaft
18	1	268311	Bearing Plate, LH
19	1	268312	Bearing Plate, RH(not shown)
20	1/rw	266072	Paddle, Assembly
21			
22	2	980821	Flanged Bearing, 1 15/16
23			
24			
25	2	980029	Pillow Block Bearing, 1 15/16
26	1	265875	Adjusting Plate
27	2	266924	Deflector
28	10	997904	Eye Bolt, 5/8 x 6
	8	997904	Eye Bolt, 5/8 x 6 (30" Row Quantity)
29	2	267292	Slip Clutch Assembly (See Page 13)
30			
31	9	268413	Paddle Cover, Outside
32	2	268411	Paddle Cover, Inside
33			
34			
35	1	268415	Paddle Cover, Row Finder Row
36	1	267780	Clamp Bar, R.F. Row (Standard Struts Only)
37	1	270244	Rubber Latch(not shown)

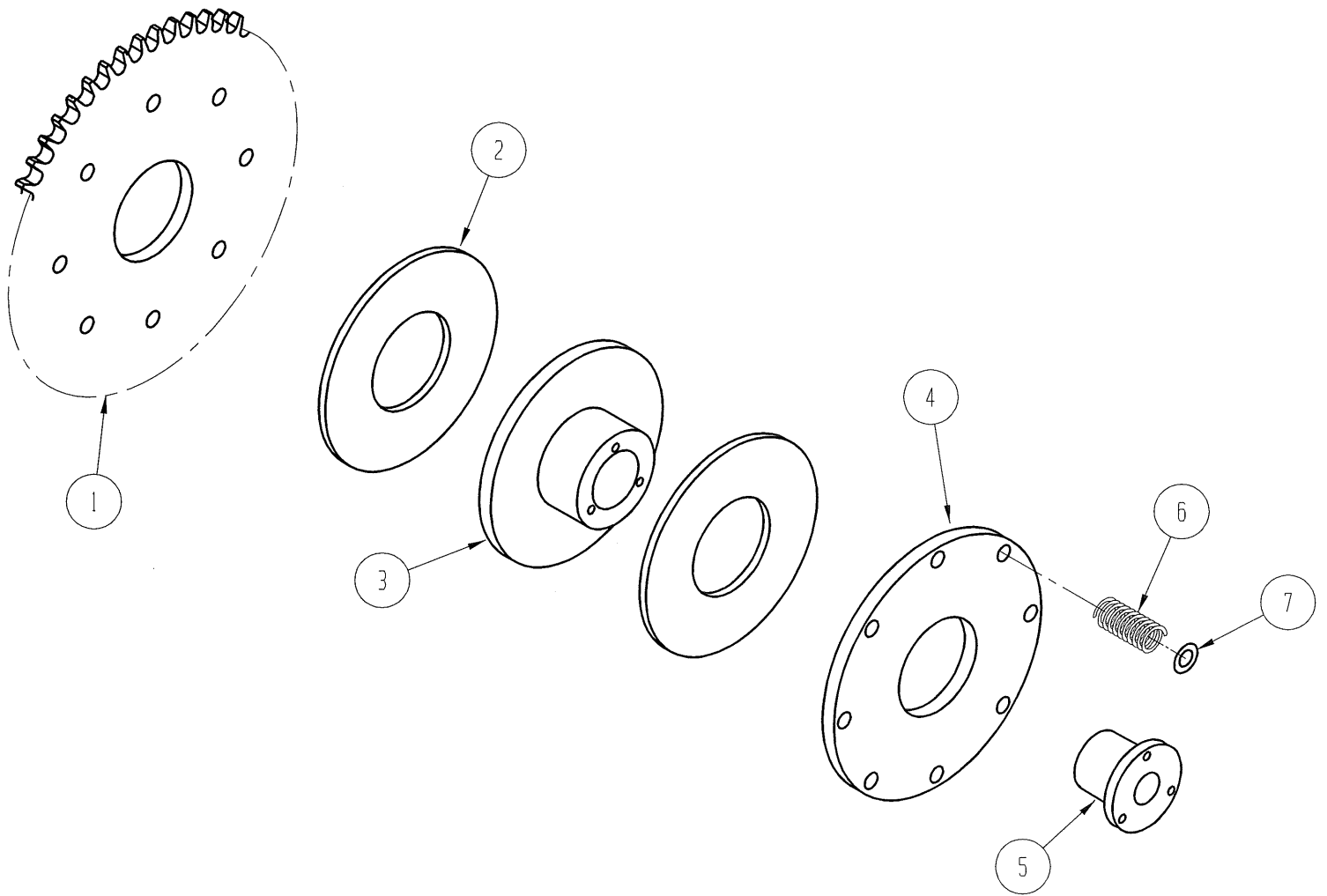

SLIP CLUTCH ASSEMBLY
(Paddle Shaft)

ITEM NO.	QUANTITY	PART NO.	DESCRIPTION
1	1	267387	Sprocket, 80A45
2	2	265763	Fiber Disk
3	1	265764	Hub
4	1	265765	Clutch Plate
5	1	980219	Bushing, Q1 1 15/16
6	8	265761	Spring
7	8	264786	Washer
8	1	267292	Clutch Assembly, Less Bushing

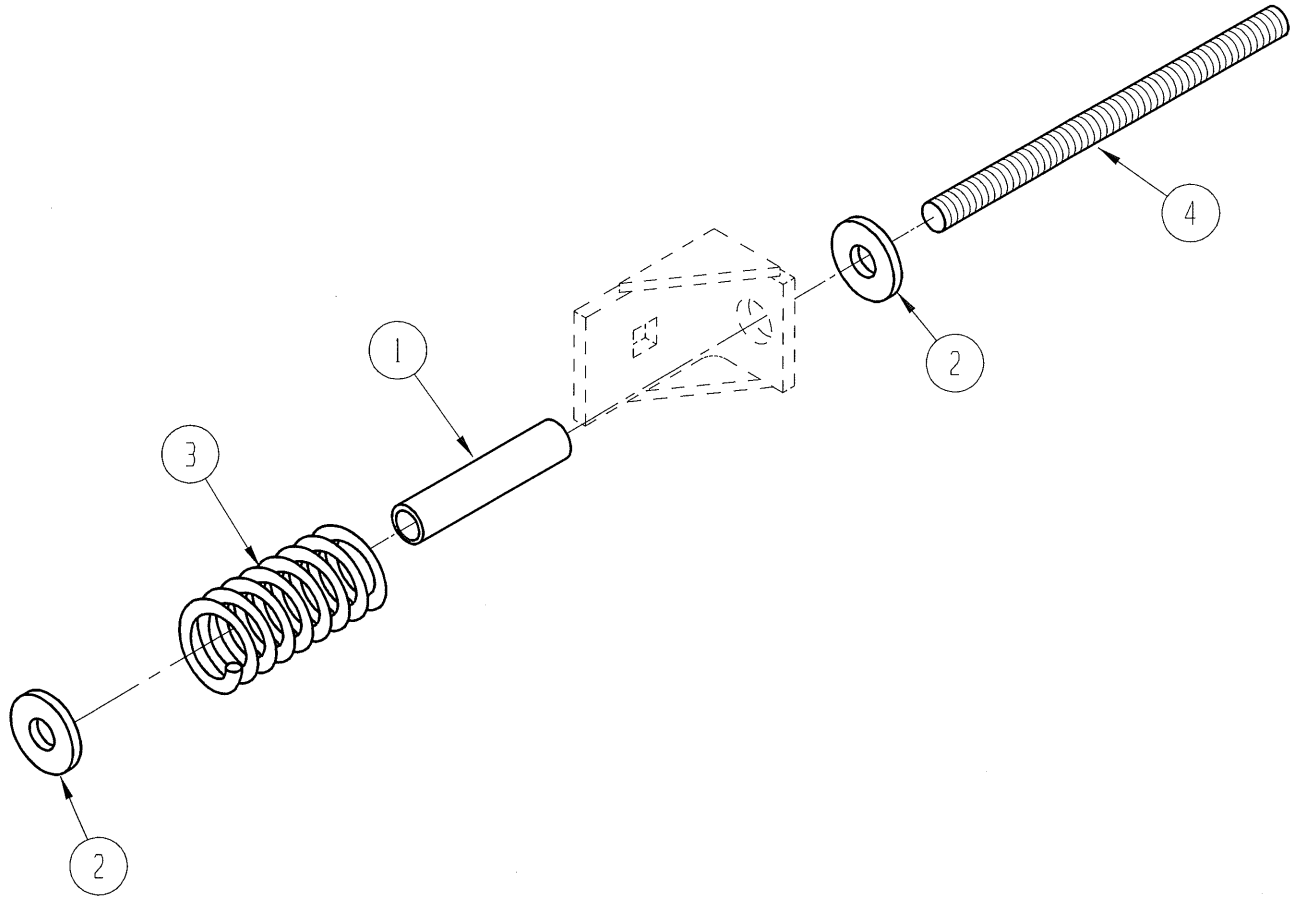

GRAB ROLL ROCK SPRING KIT
268016 for 12228

ITEM NO.	QUANTITY	PART NO.	DESCRIPTION
1	As Req'd	265249	Spring Spacer
2	As Req'd	-----	Flat Washer, ³ / ₄
3	As Req'd	264737	Spring
4	As Req'd	267268	Adjusting bolt

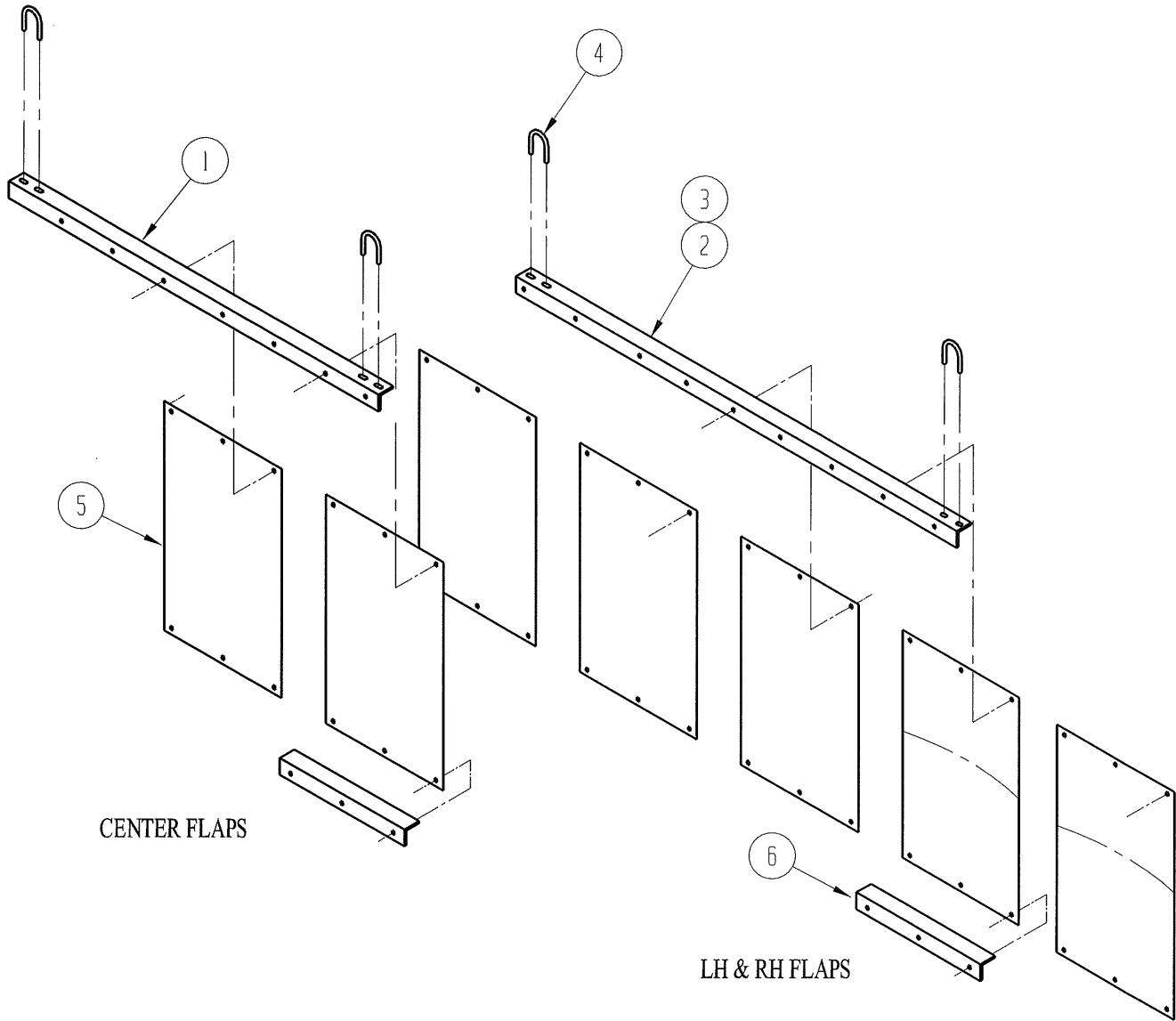

GRAB ROLL MUD FLAPS

ITEM NO.	-----	QTY	-----	PART NO.	DESCRIPTION
		12228		12228	
1	-	1	-----	268703	Center Flap Angle
2	-	1	-----	268705	LH Flap Angle
3	-	1	-----	268706	RH Flap Angle (Not Shown)
4	-	6	-----	265280	U-Bolt
5	-	12	-----	265281	Rubber Flap
6	-	12	-----	265265	Flap Angle

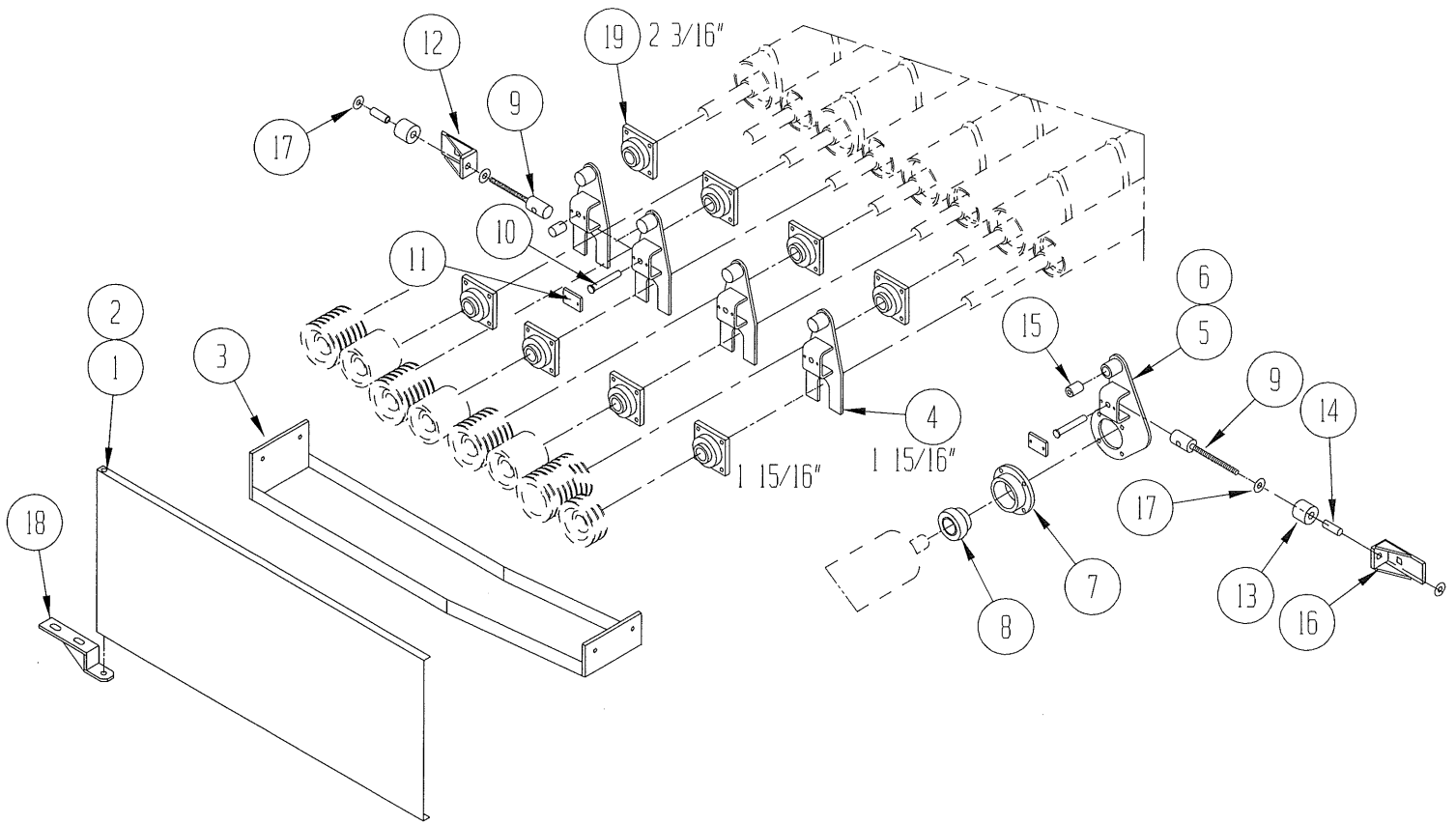

GRAB ROLL HANGERS & DOORS

ITEM NO.	QTY	PART NO.	DESCRIPTION
1	-	268305	Grab Roll Door, LH
2	-	268306	Grab Roll Door, RH
3	-	265482	Lower Guard
4	-	267873	Hanger Bracket
	-	268568	Hanger Bracket
5	-	267608	Inside Hanger Bracket, LH
6	-	267609	Inside Hanger Bracket, RH
7	-	281563	Bearing Housing
8	-	268927	Bearing Insert, 1 15/16
9	-	267266	Adjusting Bolt
10	-	267640	Clevis Pin
11	-	267874	Retainer Block
12	-	264601	Take-Up Angle
13	-	264603	Cushion
14	-	264604	Spacer
15	-	264216	Bushing
16	-	267611	Take-Up Angle
17	-	264602	Washer
18	-	268309	Hinge Bracket
19	-	980821	Bearing, (1 15/16") 4-Bolt
	-	980827	Bearing, (2 3/16") 4-Bolt

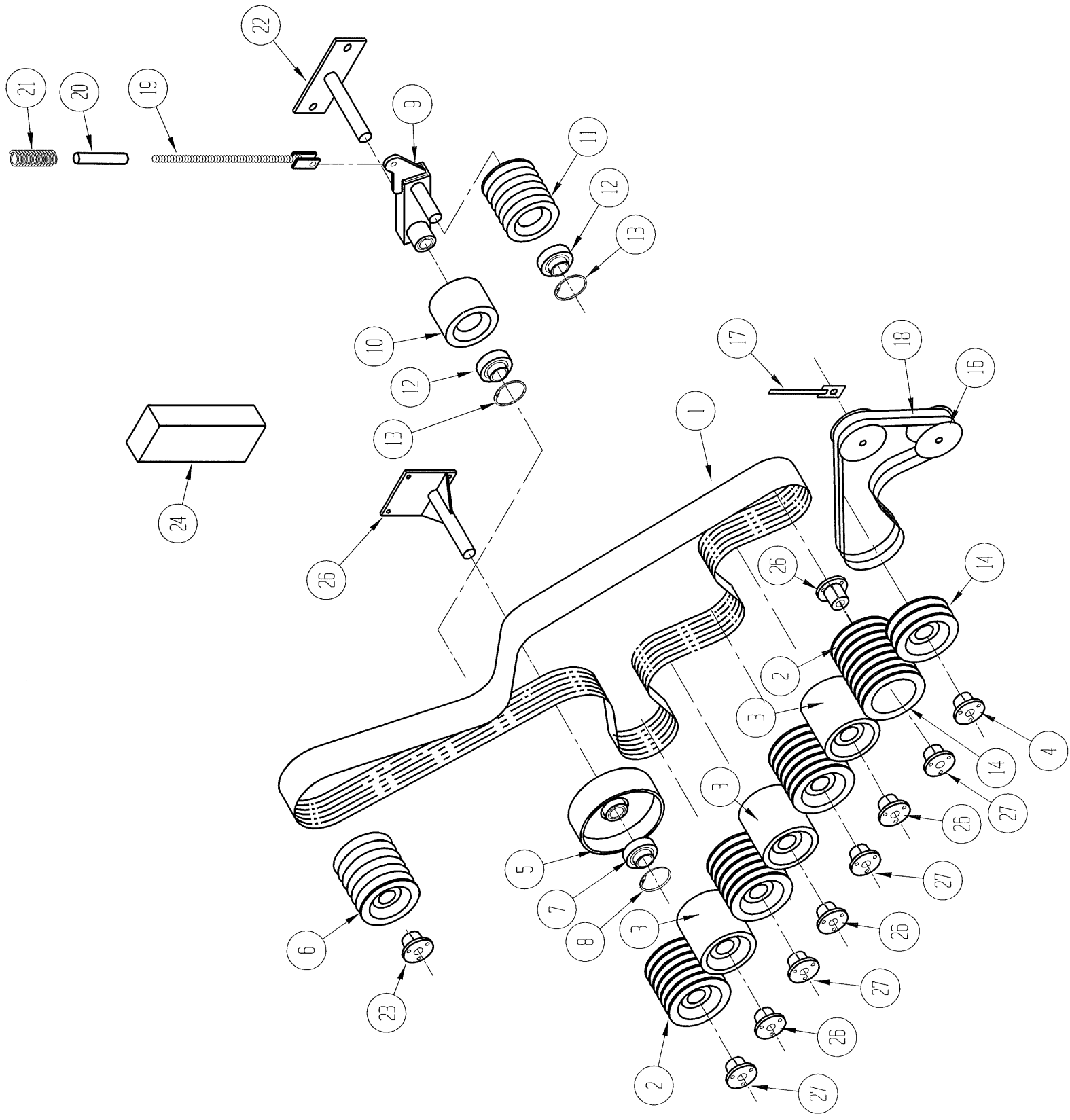

GRAB ROLL BELT DRIVE COMPONENTS

ITEM NO.	QTY	PART NO.	DESCRIPTION
		----- 12228	
1	4	268831	Power Band, 3/5VX2000 (Use Notched Only)
2	8	268829	Sheave, 6Q5V 670
3	6	265905	Smooth Pulley
4	2	980219	Bushing, Q1 1 15/16
5	2	----- 265474	Idler Assembly w/Bearings
6	2	268830	Sheave, 6R5V800
7	2	----- 980077	Bearing, 1 3/4"
8	2	----- 998915	Snap Ring
9	1	----- 267174	Idler Arm, LH shown
	1	----- 267175	Idler Arm, RH
10	2	----- 267020	Idler Assembly, 6 1/2" w/ Bearing
11	2	----- 268827	Idler Sheave Assembly w/ Bearing
12	2	----- 980073	Bearing, 1 3/8"
13	2	----- 998914	Snap Ring
14	8	----- 266327	Sheave, 2B6.4 Q1
15			
16	4	----- 265649	Idler Pulley
17	2	----- 264084	Draw Bolt
18	4	----- 265366	V-Belt, BB60
19	2	----- 266538	Draw Bolt
20	2	----- 264637	Spacer
21	2	----- 264636	Spring
22	2	----- 265471	Idler Shaft Weldment
23	2	----- 268824	Bushing, R1 1 3/4
24	2	----- 267180	Draw Bolt Cover
25	2	----- 268769	Cover
26	8	268557	Bushing, Q1 2 3/16"
27	8	268822	Bushing, Q2 2 3/16"

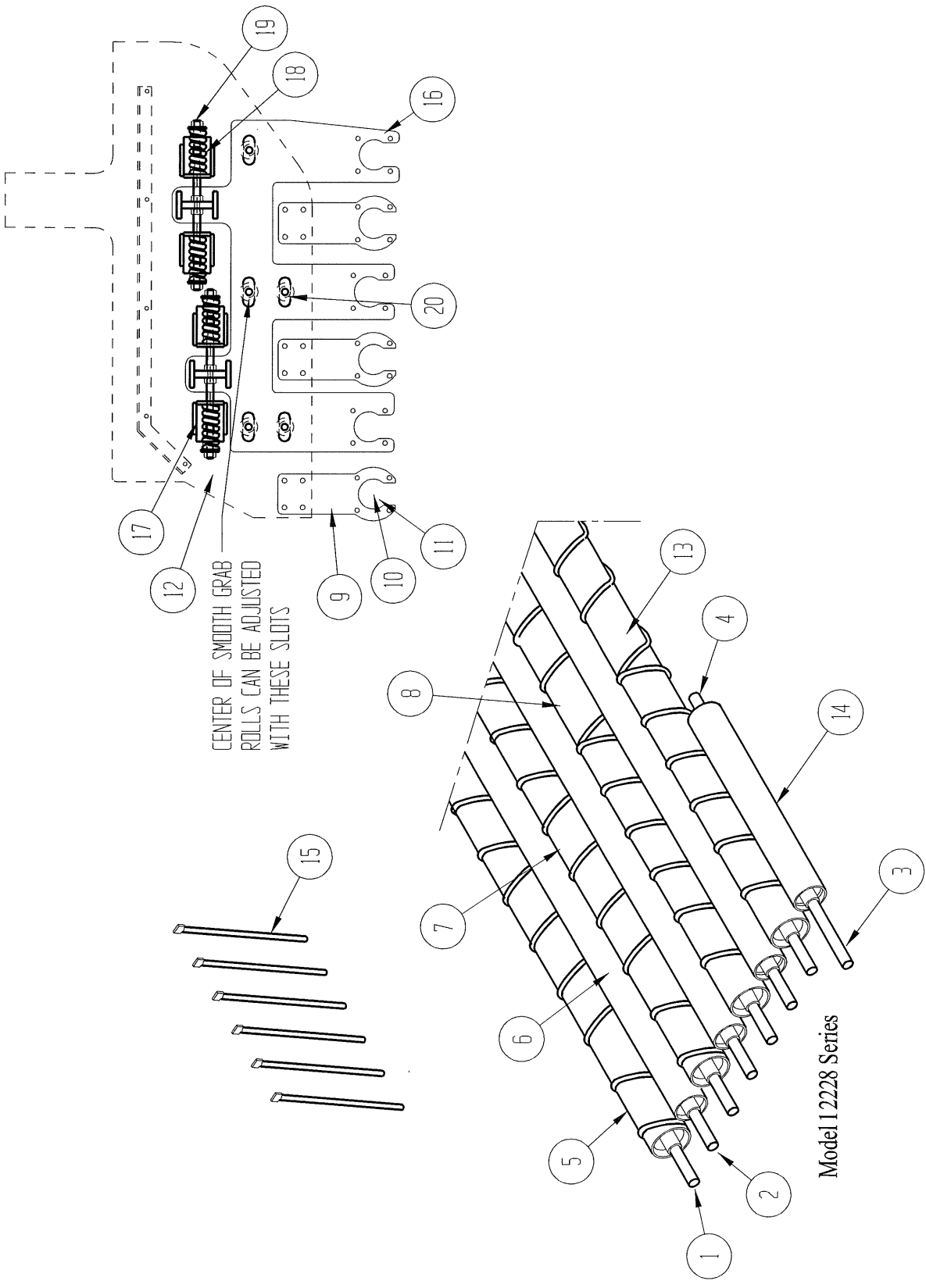

GRAB ROLL BED ASSEMBLY

ITEM NO.	QTY	PART NO. -----	PART NO. 12228	DESCRIPTION
1	8		268563	*Stub Shaft, #1, #3, #5, & #7 Grab Rolls
2	6		268563	*Stub Shaft, #2, #4, & #6 Grab Rolls
3	2		268027	*Stub Shaft, Long #8 Grab Roll
4	2		267690	*Stub Shaft, Short #8 Grab Roll
5	1		268719	Grab Roll #1 4-Way Spiral-Split(1-RH,1-LH)
6	6		268722	Grab Roll #2, #4, & #6 Smooth-Split
7	1		268723	Grab Roll #3 4- Way Spiral-Split(1-RH,1-LH)
8	1		268724	Grab Roll #5 2-Way Spiral-Split(1-RH, 1-LH)
9	6		268718	Bearing Hanger-Split Center
10	12		281563	Bearing Housing-Center
11	12		268927	Bearing Insert, 1 15/16"
12	2		268717	Bearing Hanger Plate
13	1		268528	Grab Roll #7 Solid
14	2		268781	Grab Roll #8 Short Smooth
15	128		268303	Finger Rod
16	1		268909	Bearing Hanger Bracket, RH
	1		268907	Bearing Hanger Bracket, LH
17	8		268920	Take-Up Angle
18	8		264737	Spring, 1 7/8" OD X 5"
19	4		268911	All Thread, 3/4" X 18 13/16"
20	10		268905	Bushing, Center Plate

* Weld-In Stub Shafts

The split smooth grab rolls on your 12228 harvester can be adjusted by sliding the bearing hanger plate in the center of the machine. This plate holds the three smooth grab rolls and has slots to allow forward and backward movement as needed.

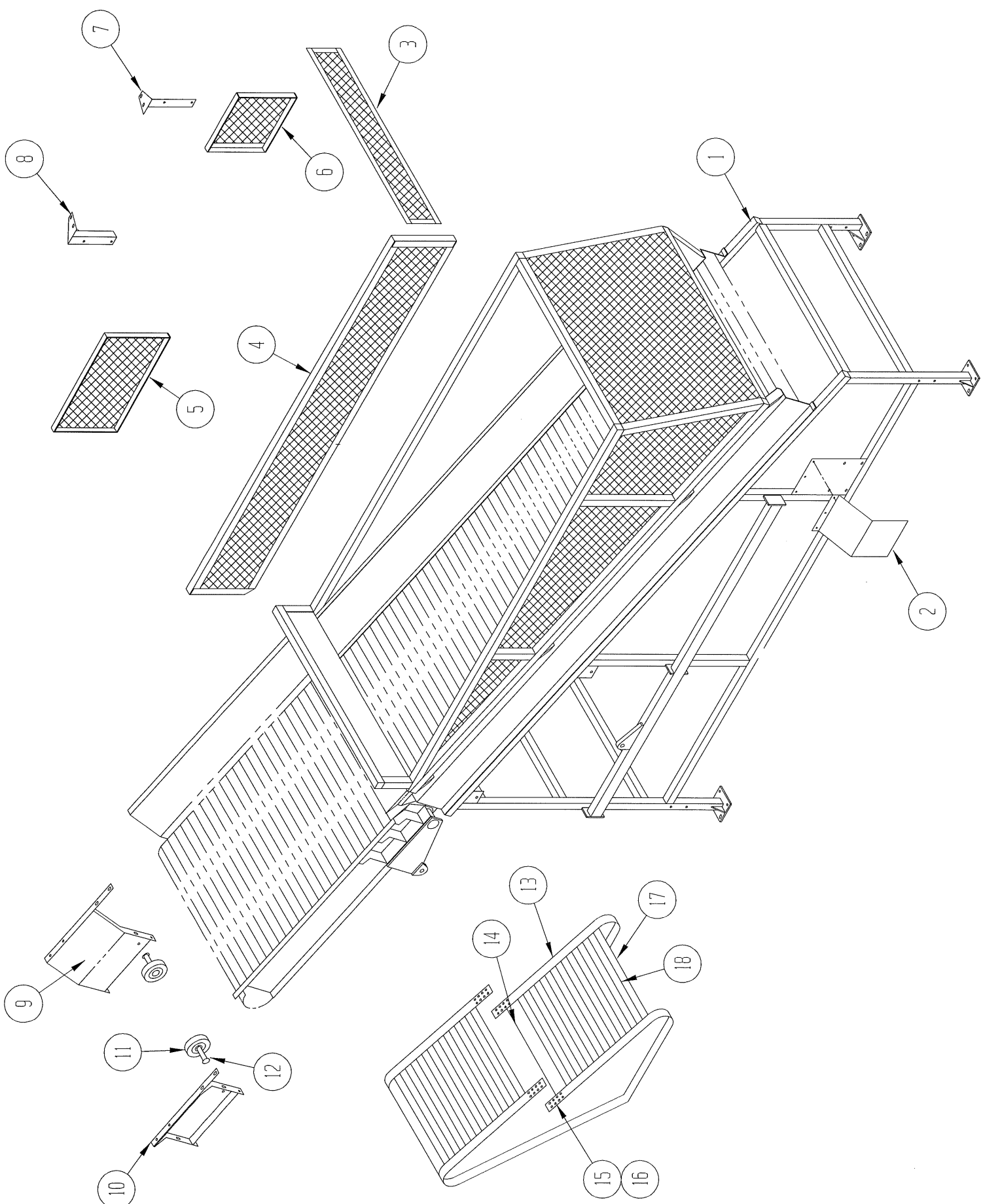

HOPPER MOUNTING & ATTACHMENTS

ITEM NO.	QTY	-----	PART NO. 12228	DESCRIPTION
1	1	-----	268615	Hopper Support
2	1	-----	267756	Cover, Valve Bank
3	1	-----	267535	Side Railing
4	1	-----	268623	Front Railing
5	1	-----	268628	Rear Railing, RH
6	1	-----	-----	Rear Railing, LH
7	1	-----	267933	Mounting Bracket, LH
8	1	-----	267934	Mounting Bracket, RH
9	1	-----	267641	Front Extension, 24" Optional
10	1	-----	267640	Front Extension, 24" Optional
11	4	-----	265150	Roller, 5"
12	4	-----	266935	Stand Off, 3 5/8"
13	1	-----		(252 Total Links)
	1		268619	(252 Total Links)
				Belted Chain, 1/2 x 48 x 56 MM, 6 str/1 up, (Includes Items #12, 13, & 14)
14	As Req'd	-----	267774	Straight Link w/ 1/4" Holes
	As Req'd	-----	268899	Chain Link, 48" Offset Up w/ 1/4" Holes
15	As Req'd	-----	998239	Backing Plate w/ Threaded Holes
16	As Req'd	-----	998240	Hex Cap Screw, 1/4-28 x 1 1/4 Grd-8, with Lock Nut. Note: Do Not Use Elastic Stop Nut.
17	As Req'd	-----	268195	Chain Link, 48" Offset Up w/ Rivet Holes
18	As Req'd	-----	268196	Chain Link, 48" Straight w/ Rivet Holes

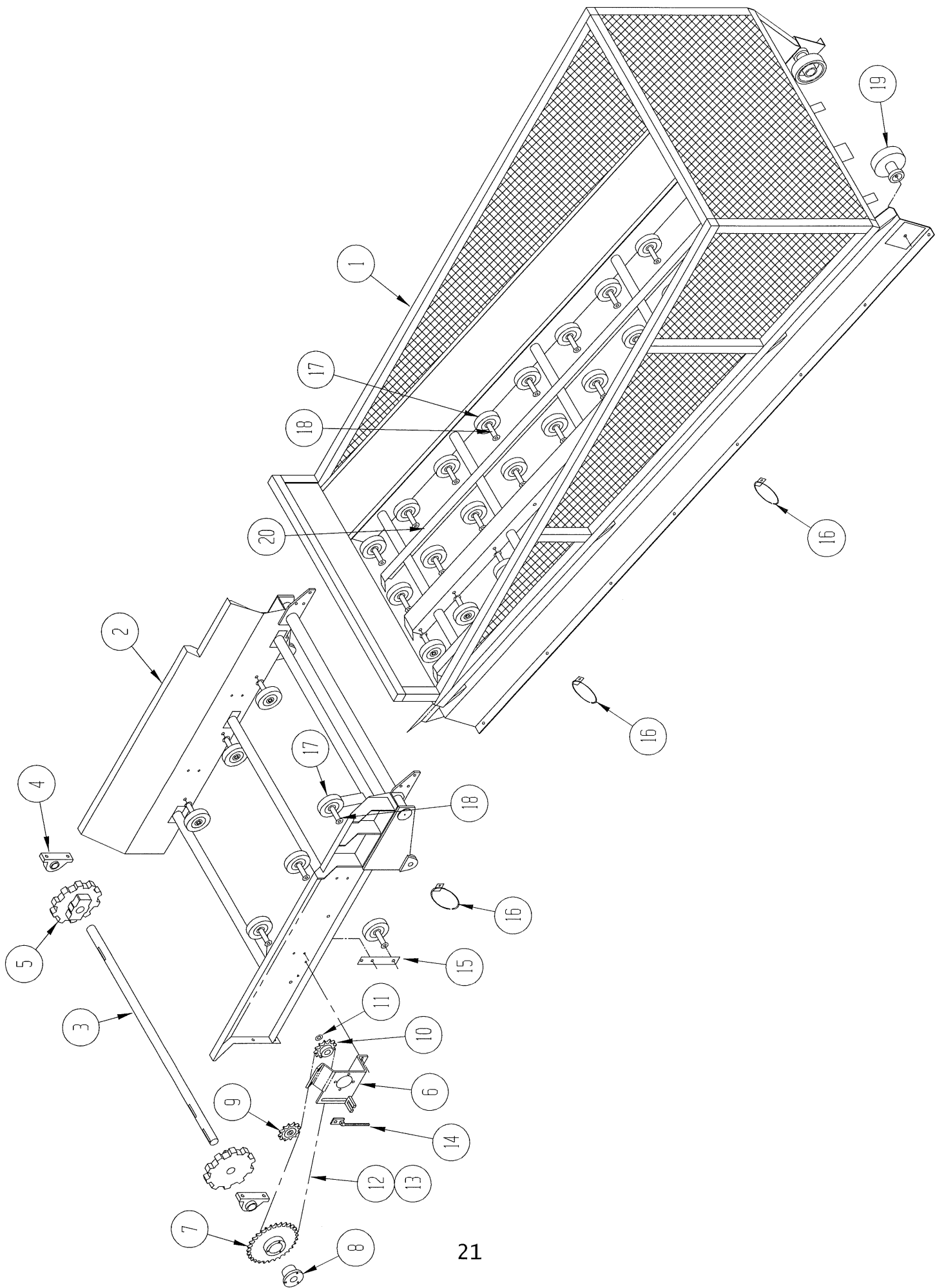

21

HOPPER ASSEMBLY

ITEM NO.	QUANTITY	PART NO.	DESCRIPTION
1	1	268559	Hopper Weldment
2	1	268880	Outer Boom Weldment
3	1	267726	Head Shaft
4	2	980028	Pillow Block Bearing, 1 3/4"
5	2	268261	Sprocket, 12T, 56 MM
6	1	267644	Motor Bracket
7	1	267295	Sprocket, 80Q 36 Tooth
8	1	980218	Bushing, Q1-1 3/4"
9	1	980751	Idler Sprocket, RC80 12T
10	1	980623 1-1/4	Sprocket, RC80 12T 1 1/4" Bore
11	1	-----	Fender Washer, 3/8 x 2" OD
12	68 Links	980912	Roller Chain, RC80
13	1	980927	Master Link, RC80
14	1	264084	Take-Up Bolt
15	6	290022	Roller Bracket
16	3	265953	Hose Ring
17	66	267894	Roller, 6"
18	66	265935	Stand Off, 3 5/8
19	2	267413	Roller, 6 1/2 x 1 7/8 (See Page 28)
20	3	269030	UHMW Wear Slat

CRITICAL!! ASSEMBLE THE BELTED CHAINS WITH THE OVERLAP IN THE DIRECTION AS SHOWN

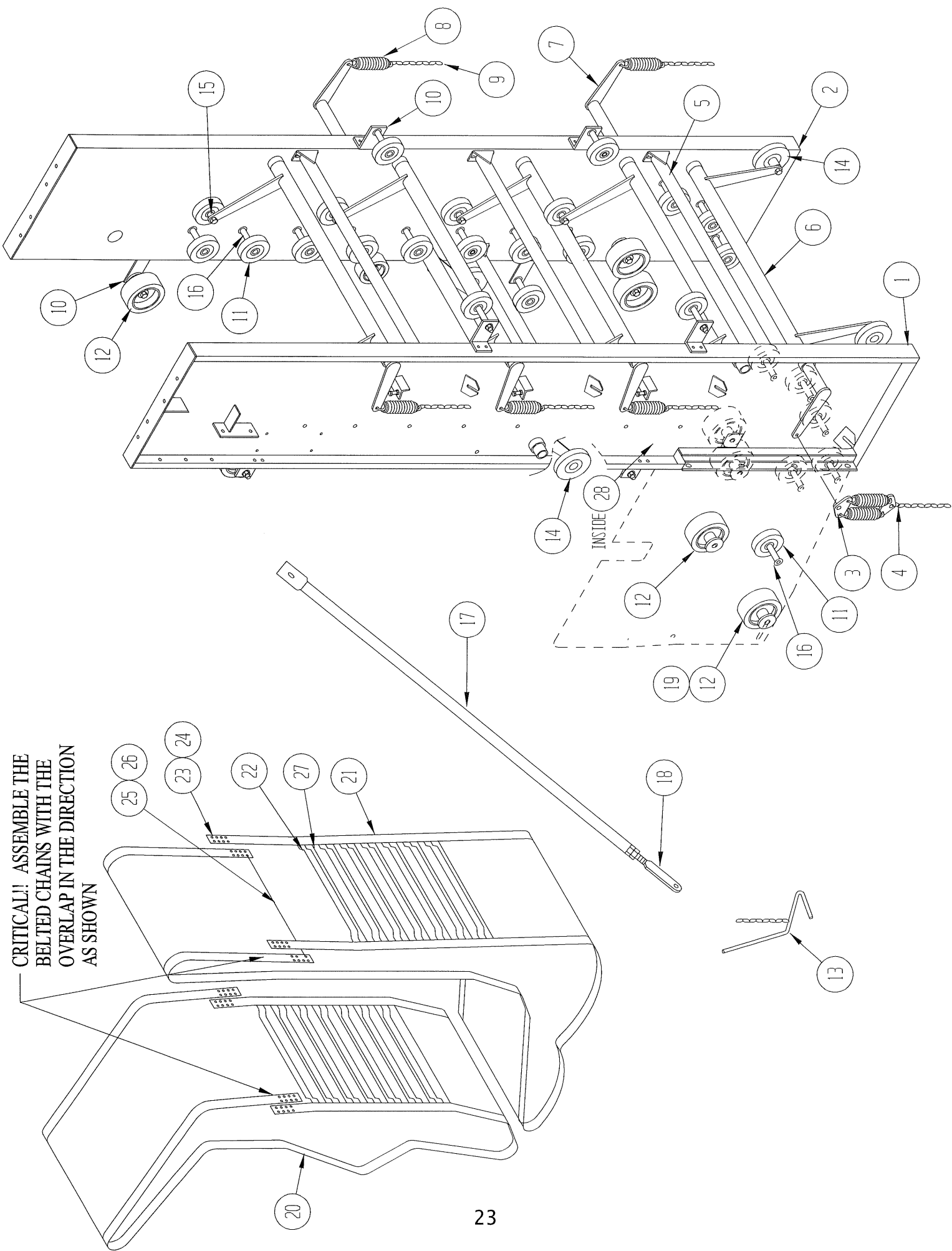

REAR ELEVATOR ASSEMBLY

ITEM NO.	QUANTITY	PART NO.	DESCRIPTION
1	1	268780	Elevator Panel (LH)
2	1	268775	Elevator Panel (RH)
3	2	290243	Spring Bracket
4	2	290244	Cold Shut, 5/16"
5	5	268749	Elevator Spreader
6	6	268750	Chain Tightener
7	6	268751	Spring Arm
8	7	998986	Extension Spring
9	6	981231	1/4 Proof Coil Chain-12 Links
10	4	267786	Roller Bracket
11	70	265150	Roller, 5" (See Page 28)
12	10	267413	Roller Asm w/ 3" Base (See Page 28)
13	1	264685	Spring Extension Tool
14	4	267894	Roller, 6" Rubber
15	12	265151	Spacer
16	54	266935	Standoff 5/8 x 3 5/8
17	1	264064	Elevator Support Rod (Includes Item #28)
18	1	290471	Adjusting Rod
19	2	-----	Hex Bolt, 5/8 x 5 Grade 8
20	1	268886	Belted Chain (Front) 1/2 x 56 x 56MM all down. (Includes Items 23, 24, 25) (153 Links plus 4 overlap)
21	1	268745	Belted Chain (Back) 1/2 x 56 x 56MM 1 strt/3 down. (Includes Items 23, 24, 25, & 26) (180 Links plus 4 overlap)
22	-----	-----	-----
23	As Req'd	998240	Hex Cap Screw, 1/4-28 x 1 1/4 Grd-8, w/ Lock Nut. Note: Do Not Use Elastic Stop Nut
24	As Req'd	998239	Backing Plate w/ Threaded Holes
25	As Req'd	268744	Chain Link, Offset Down w/ 1/4" Holes
26	As Req'd	268743	Chain Link, Straight w/ 1/4" Holes
27	-----	-----	-----
28	1	268877	Roller Bracket

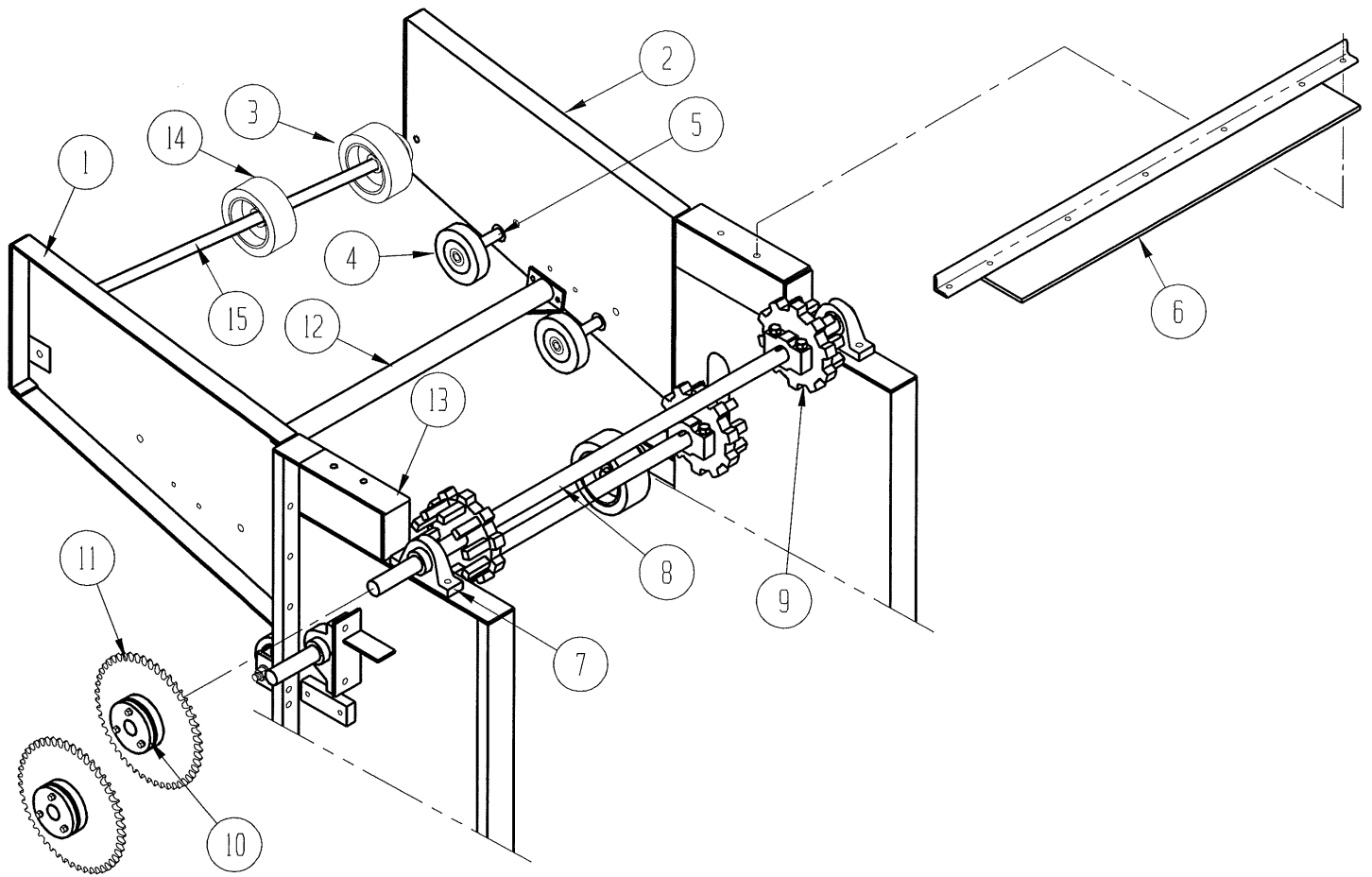

REAR ELEVATOR TOP ASSEMBLY

ITEM NO.	QUANTITY	PART NO.	DESCRIPTION
1	1	268251	Top Panel, LH
2	1	268253	Top Panel, RH
3	2	267413	Roller Asm w/ 3" Base (See Page 28)
4	4	265150	Roller, 5" (See Page 28)
5	4	265935	Stand Off, 3 5/8"
6	1	268540	Flap Assembly
7	4	980028	Pillow Block Bearing 1 3/4
		980104	1 3/4" Bearing insert for Item #7
8	2	268756	Elevator Head Shaft
9	6	268261	Split Sprocket, 12T x 56MM -1 3/4Bore
10	2	980218	Bushing, Q1-1 3/4
11	2	267295	Sprocket 80Q36T
12	1	268749	Spreader
13	2	268255	Spacer Block
14	3	268876	Roller Assembly, 1 3/8" Bearing
15	3	268873	Roller Shaft

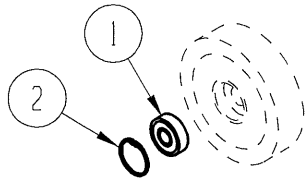

5 IN. ROLLER ASSEMBLY
PART #265150

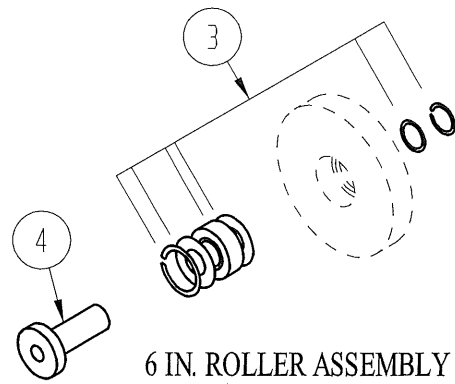

6 IN. ROLLER ASSEMBLY
PART #266494

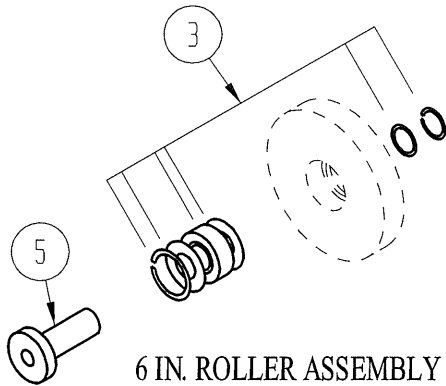

6 IN. ROLLER ASSEMBLY
PART #265719

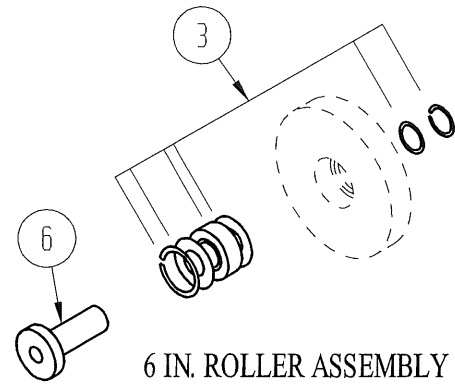

6 IN. ROLLER ASSEMBLY
PART #265718

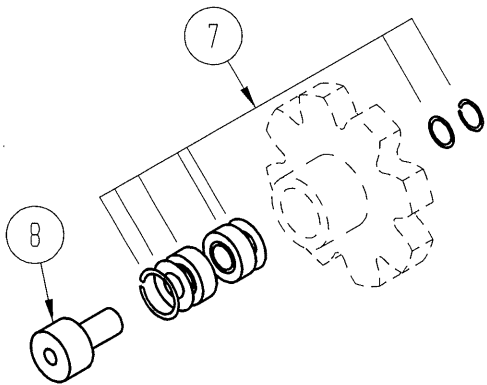

IDLER SPROCKET ASSEMBLY 8T 56MM
PART #266119

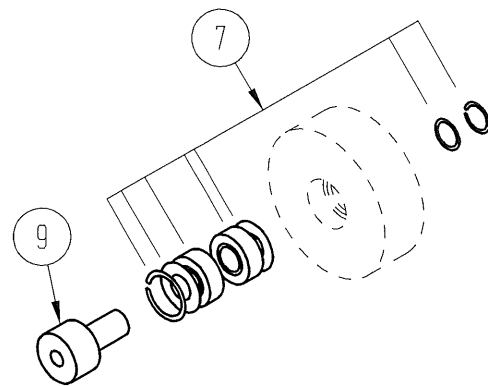

6" ROLLER ASSEMBLY
PART #267413

ROLLERS & IDLER SPROCKETS

ITEM NO.	QUANTITY PER ROLLER	PART NO.	DESCRIPTION
1	1	980081	Bearing, 5/8
2	1	998946	Snap Ring
3	1	265957	Bearing Repair Kit
4	1	267172	Stub Shaft, GB2 w/ 3" Base
5	1	265955	Stub Shaft, J2
6	1	265956	Stub Shaft, D2
7	1	265959	Bearing Repair Kit
8	1	265960	Stub Shaft w/ 3" Base
9	1	267415	Stub Shaft w/ 3" Base

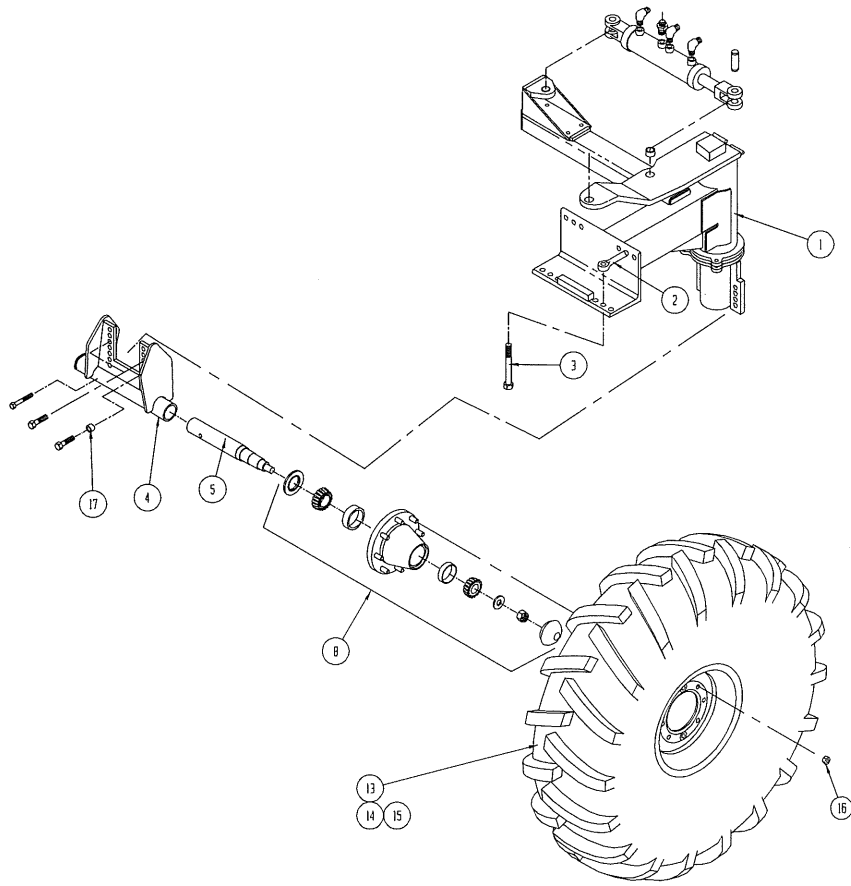

STEERABLE REAR WHEEL ASSEMBLY

ITEM NO.	QUANTITY	PART NO.	DESCRIPTION
1	1	267964	Upper Strut, RH
2	1	267960	Upper Strut, LH
3	1	265233	Cylinder Ear
4	1	268697	Tie Rod Assembly w/Bushings
5	1	250098	Tie Rod End
6	4	267278	Spindle
7	4	817718	Seal
8	4	-----	Bearing Cone (Inner)
9	4	-----	Bearing Cup (Inner)
10	4	-----	Wheel Hub with Cups
11	4	310036	Hub Asm(Includes Lugs, Bearings, Seals, Races)
12	4	-----	Bearing Cone (Outer)
13	4	999965	Flat Washer-7/8
14	4	999960	Castle Nut-7/8
15	4	999952	Hub Cap
16	4	266667	Wheel and Tire Assembly
17	4	-----	-----
18	4	-----	-----
19	32	997905	Lug Bolt
20	1	998943	Hydraulic Cylinder, 3 x 6(1-Way Steering) See page 32 for 2-Way Return to Straight Steering
21	2	-----	Hose Assembly, 1/2 100R1 x 96 w/ 1/2 Male Rigid & 1/2 Female Swivel Ends
22	2	-----	Key, 1/2 Sq. x 3 1/4
23	1	267927	Hydraulic Tube Assembly
24	2	267678	Middle Strut
25	4	264714	Spacer
26	8	997903	Eye Bolt 3/4 x 6 1/2
27	4	990003	Bearing Cup (Outer)
28	5	990251	Bushing
29	2	295043	Male 90° Elbow, 1/2 x 1/2 O-Ring
30	1	265012	Cylinder Stop
31	2	268695	Strut Bottom
32	1	990250	Bushing
33	8	-----	Hex Cap Screw, 3/4 x 8 1/2
34	2	282058	Bushing, R1-2 3/16
35	2	267962	Steering Arm
36	2	267322	Wear Disk
37	2	268420	Floatation Strut Wld(Optional)(not shown)
38	2	701282	Floatation Strut Spindle(Optional)
39	2	701283	Hub Package(Optional)
40	2	701351	16.1 Wheel, 3 3/16 Offset(Optional)
41	2	268113	Tire 21.5 x 16.1 Traction(Optional)
42	2	701325	Tube(Optional)
43	1	268428	Tie-Rod Assembly(Optional)

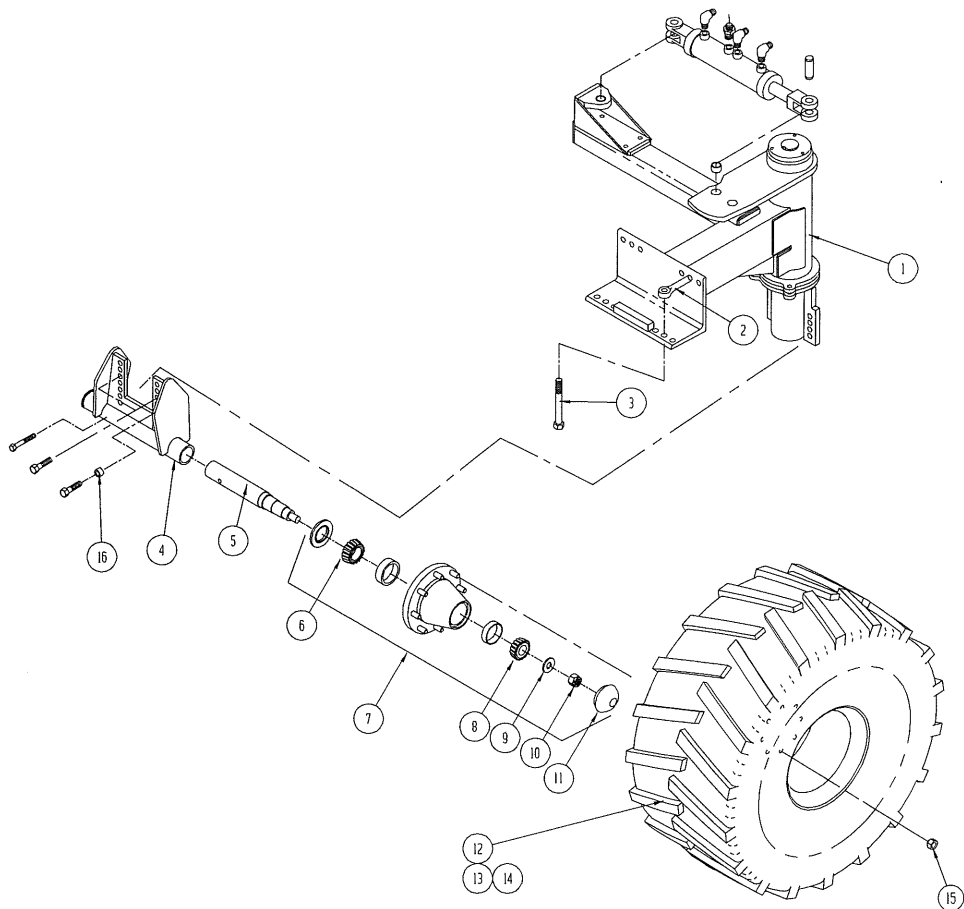

STEERABLE FLOATATION WHEEL STRUT ASSEMBLY

ITEM NO.	QUANTITY	PART NO.	DESCRIPTION
1	2	268764	Strut Assembly HD Steering
2	12	997903	Eye Bolt 3/4 x 6 1/2
3	12	-----	Hex Cap Screw 3/4 x 8 1/2
4	4	268760	Lower Strut
5	4	268851	Spindle
6	4	701882	Inner Bearing Cone
7	4	701283	Wheel Hub Asm
8	4	701883	Outer Bearing Cone
9	4	-----	7/8 Flat Washer
10	4	-----	7/8 Slotted Nut
11	4	701886	Hub Cap
12	4	701351	Wheel 16.1" Wheel 3 3/16 Offset
13	4	268113	Tire 21.5x16.1 Traction Lug
14	4	701325	Tube
15	40	701717	Flange Nut
	40	701716	Wheel Stud
16	16	264714	Spacer

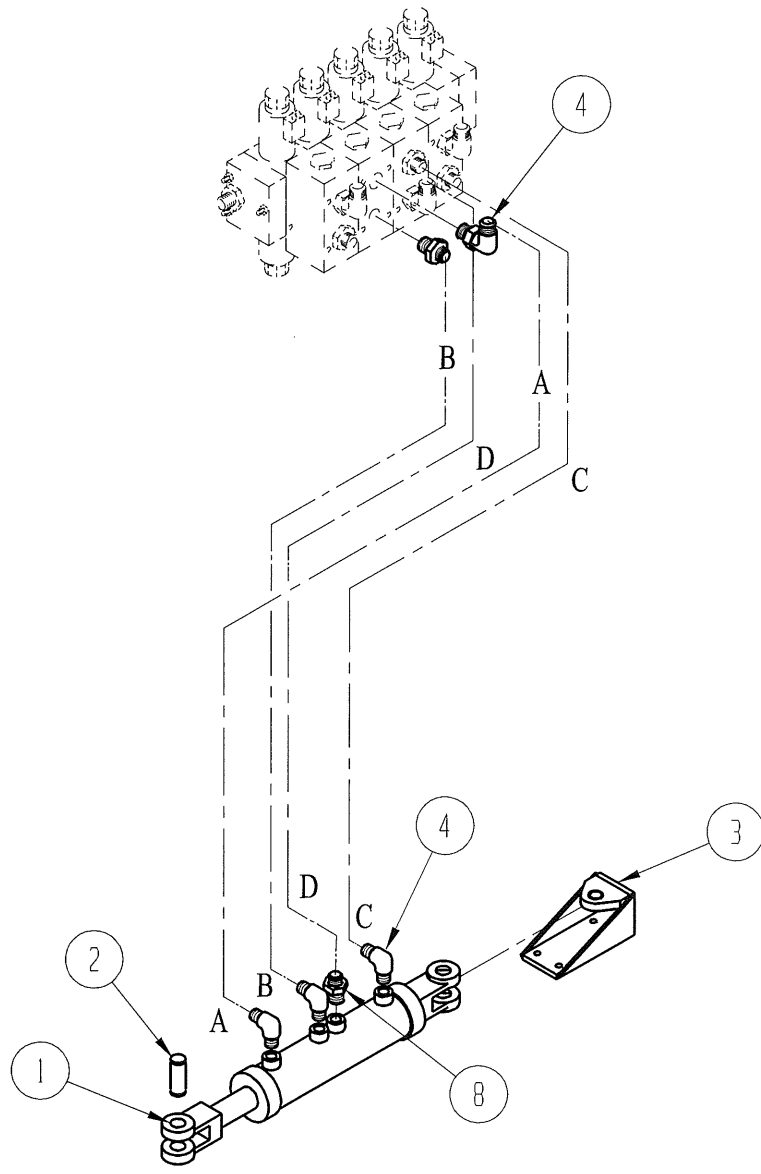

**2-WAY STEERING RETURN TO STRAIGHT
265228**

ITEM NO.	QUANTITY	PART NO.	DESCRIPTION
1	1	265226	Double Rod Cylinder
2	2	265254	Cylinder Pin w/ Hair Pins
3	1	265236	Cylinder Ear
4	4	295043	Straight Thread Elbow, 1/2 X 1/2 O-Ring

**See Page 31 for Valve Parts Breakdown

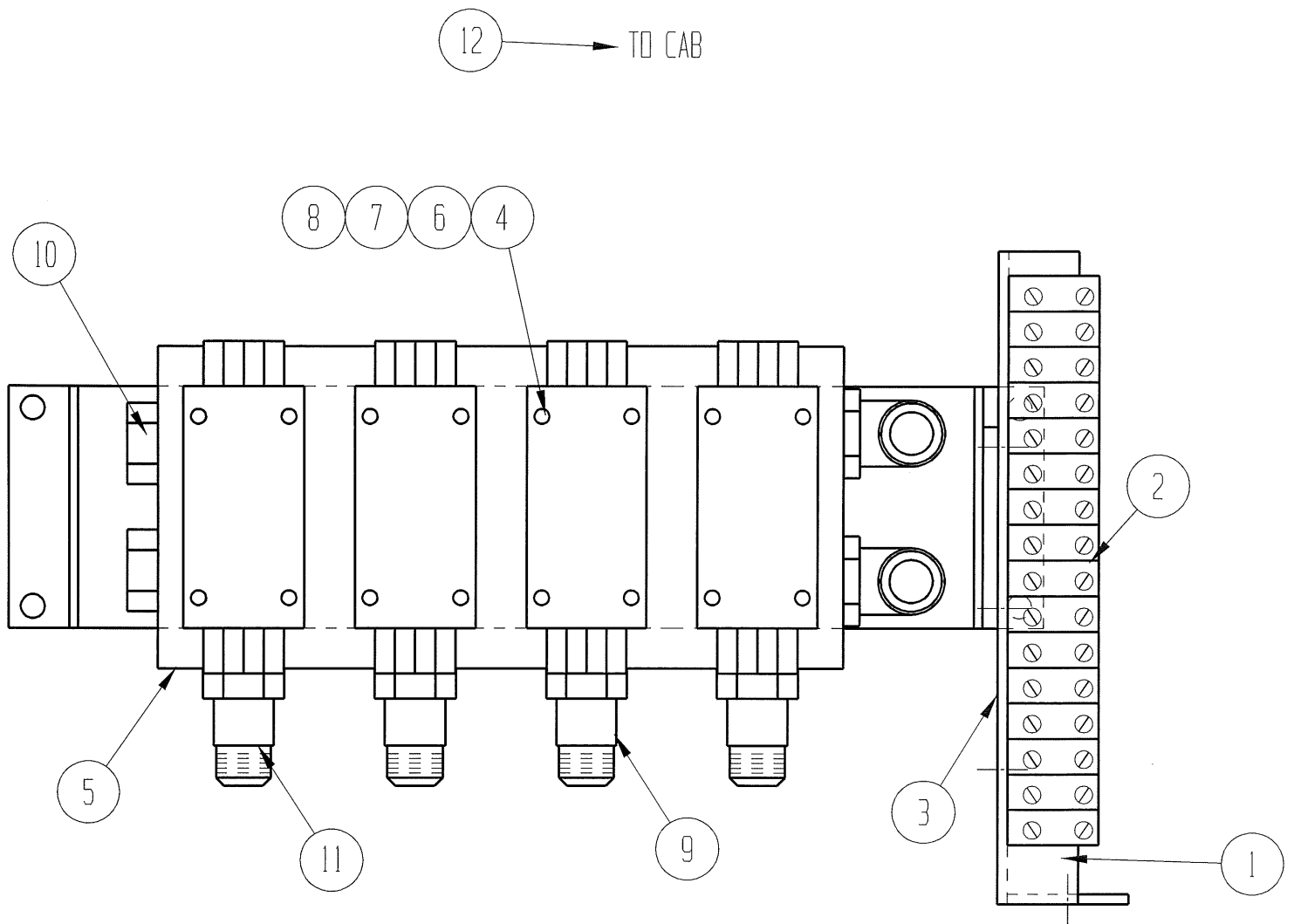

VALVE BANK ASSEMBLY
269029 4-Bank Valve Assembly

ITEM NO.	QUANTITY	PART NO.	DESCRIPTION
1	1	269049	Angle Bracket
2	1	264713	16 Wire Terminal Block
3	1	264709	Terminal Mounting Bracket
4	4	701660	Bolt/Mounting Kit
5	1	269022	4-Station Manifold
6	4	701659	P.O. Check Valve
7	4	282879	Cylinder Valve
8	8	701629	3' Pigtail Wire
9	6	0503-8-8	Str Thread Connector
10	2	05CP-10	O-Ring Plug
11	2	2503-10-10	Str Thread Elbow
12	1	268363	Tractor Cab Plug-In
13	2	701658	Restrictor Fitting Str Thread(Discharge Boom)

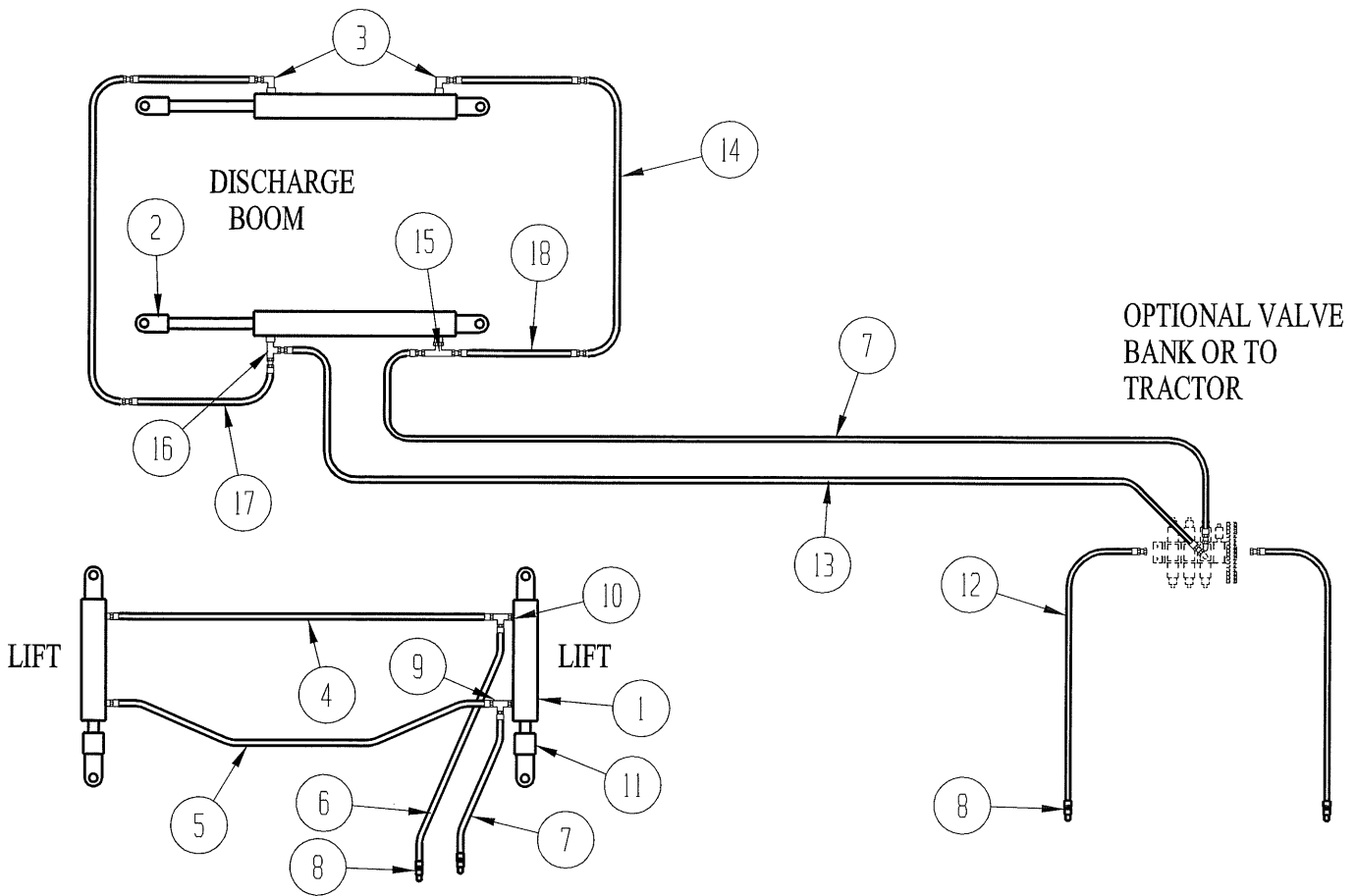

HYDRAULIC SCHEMATIC (Cylinders)

ITEM NO.	QUANTITY	PART NO.	DESCRIPTION
1	2	998403	Hydraulic Cylinder 4 x 8
2	2	300086	Hydraulic Cylinder 2 1/2 x 24
3	2	C5405-8-8	Male Elbow, 90° x 1/2 O-Ring
4	1	-----	Hyd. Hose, 1/2 100R2 x 41 w/ 1/2 JIC M & F Ends
5	1	-----	Hyd. Hose, 1/2 100R2 x 51 w/ 1/2 JIC M & F Ends
6	1	-----	Hyd. Hose, 1/2 100R2 x 144 w/ 1/2 JIC M Ends
7	1	-----	Hyd. Hose, 1/2 100R2 x 102 w/ 1/2 JIC F Ends
8	4	291027	Quick Coupler, 1/2
9	2	C5705-8	Union Tee, 1/2 JIC
10	2	C5315-8	Connector, 1/2 x 1/2 O-Ring
11	2	522012	Stroke Control Kit
12	1	-----	Hyd. Hose, 1/2 100R2 x 192 w/ 1/2 Male Pipe
Rigid			& F JIC Swivel Ends
13	1	-----	Hyd. Hose, 1/2 100R2 x 128 w/ 1/2 JIC F Ends
14	2	266160	Hydraulic Tube Asm
15	1	C5715-8	Straight Thread Branch Tee, 1/2 JIC
16	1	C5716-8	Straight Thread Run Tee, 1/2 JIC
17	2	-----	Hyd. Hose, 1/2 100R2 x 48 w/1/2 JIC M Rigid & F Swivel Ends
18	2	-----	Hyd. Hose, 1/2 100R2 x 75 w/1/2 JIC M Rigid & F Swivel Ends

*Please specify brand of cylinder involved when ordering seal kits.

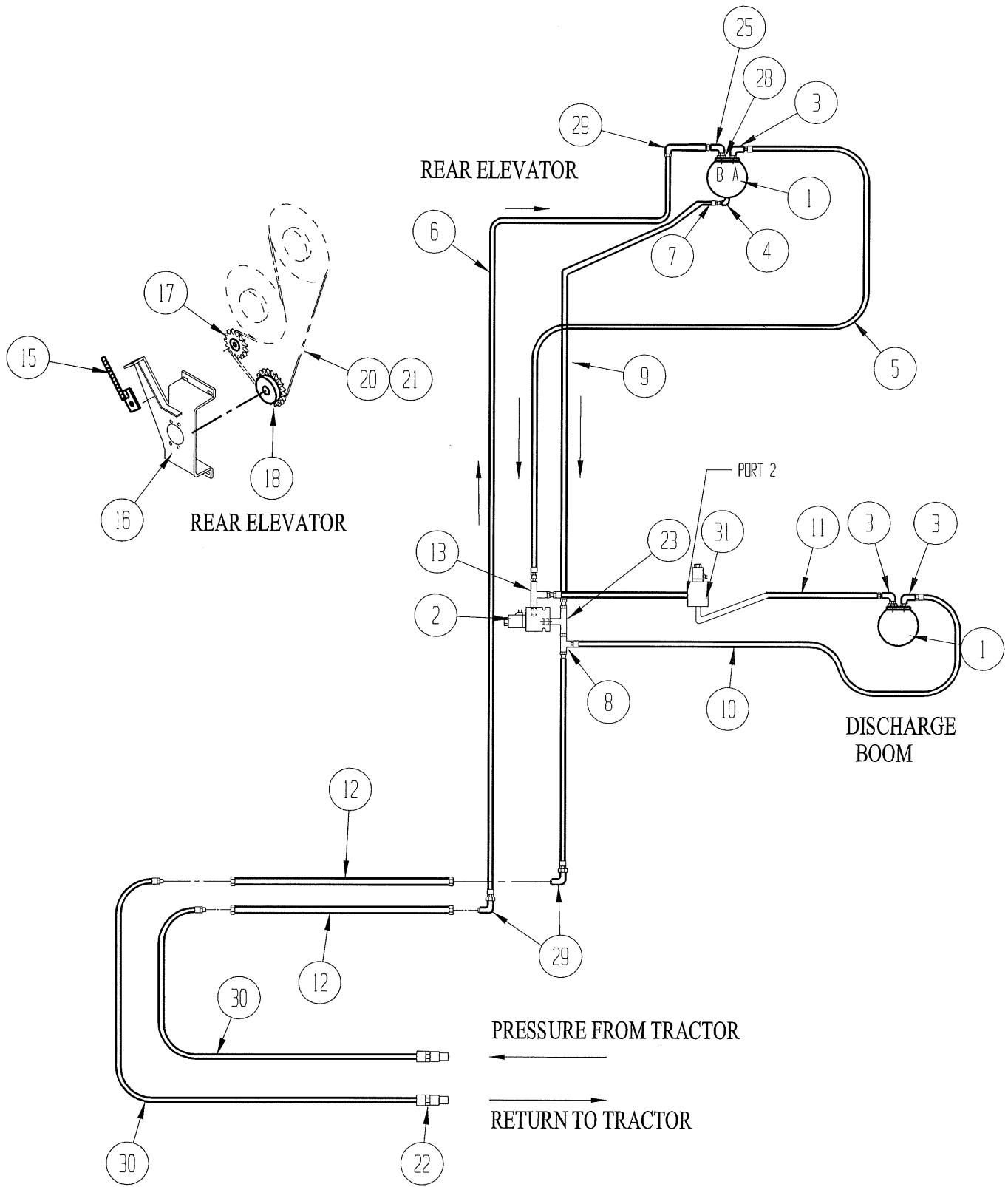

HYDRAULIC SCHEMATIC
(Motor Drives, Tractor Driven)

ITEM NO.	QUANTITY	PART NO.	DESCRIPTION
1	2	701378	Hydraulic Motor
2	1	267766	Dump Valve
		267801	Replacement Coil for Item #2
		267767	Replacement Cartridge for Item #2
3	3	C5515-12	Straight Thread Elbow
4	1	C5515-6-4	Straight Thread Elbow
5	1	-----	Hydraulic Hose Asm, 3/4 100R2 x 70 w/ 3/4 JIC Female Swivel Ends
6	1	-----	Hydraulic Hose Asm, 3/4 100R2 x 110 w/ 3/4 JIC Male Rigid & Female Swivel Ends
7	1	-----	Hydraulic Hose Asm, 1/4 x 10 w/ 3/8 JIC Female Swivel Ends
8	1	C5706-12	Swivel Nut Run Tee
9	1	-----	Hydraulic Hose Asm, 3/4 100R2 x 100 w/ 3/4 JIC Female Swivel Ends
10	1	-----	Hydraulic Hose Asm, 3/4 100R2 x 163 w/ 3/4 Female Swivel Ends
11	1	-----	Hydraulic Hose Asm, 3/4 100E2 x 155 w/ 3/4 JIC Female Swivel Ends
12	2	267927	Tube Assembly
13	1	C5716-12	Straight Thread Run Tee
14	1	266162	Elbow
15	1	264084	Draw Bolt
16	1	268803	Motor Mounting Bracket
17	1	980751	Idler Sprocket, 12 Tooth RC 80
18	1	980633	Sprocket, 80B22 1 1/4" Bore 5/16" KW
19	-	-----	-----
20	98 Links	980912	Roller Chain, RC80
21	1	980927	Master Link, RC80
22	2	291027	Quick Coupler, 1/2 Male
23	1	C5705-12	Branch Tee
24	1	264886	Relief Valve
		264887	Relief Valve Cartridge Only
25	2	C5506-12	Swivel Nut Elbow, 3/4 JIC
26	2	C5216-12-12	Straight Thread Connector
27	1	C5405-6	Elbow
28	1	C5315-10-12	Straight Thread Connector
29	3	C5505-12	Union Elbow, 3/4 JIC
30	2	-----	Hydraulic Hose Assembly, 3/4 100R2 x 216 w/ 3/4 JIC Male & 1/2 Male Pipe Ends
31	1	268239	Valve, Hydraulic Control

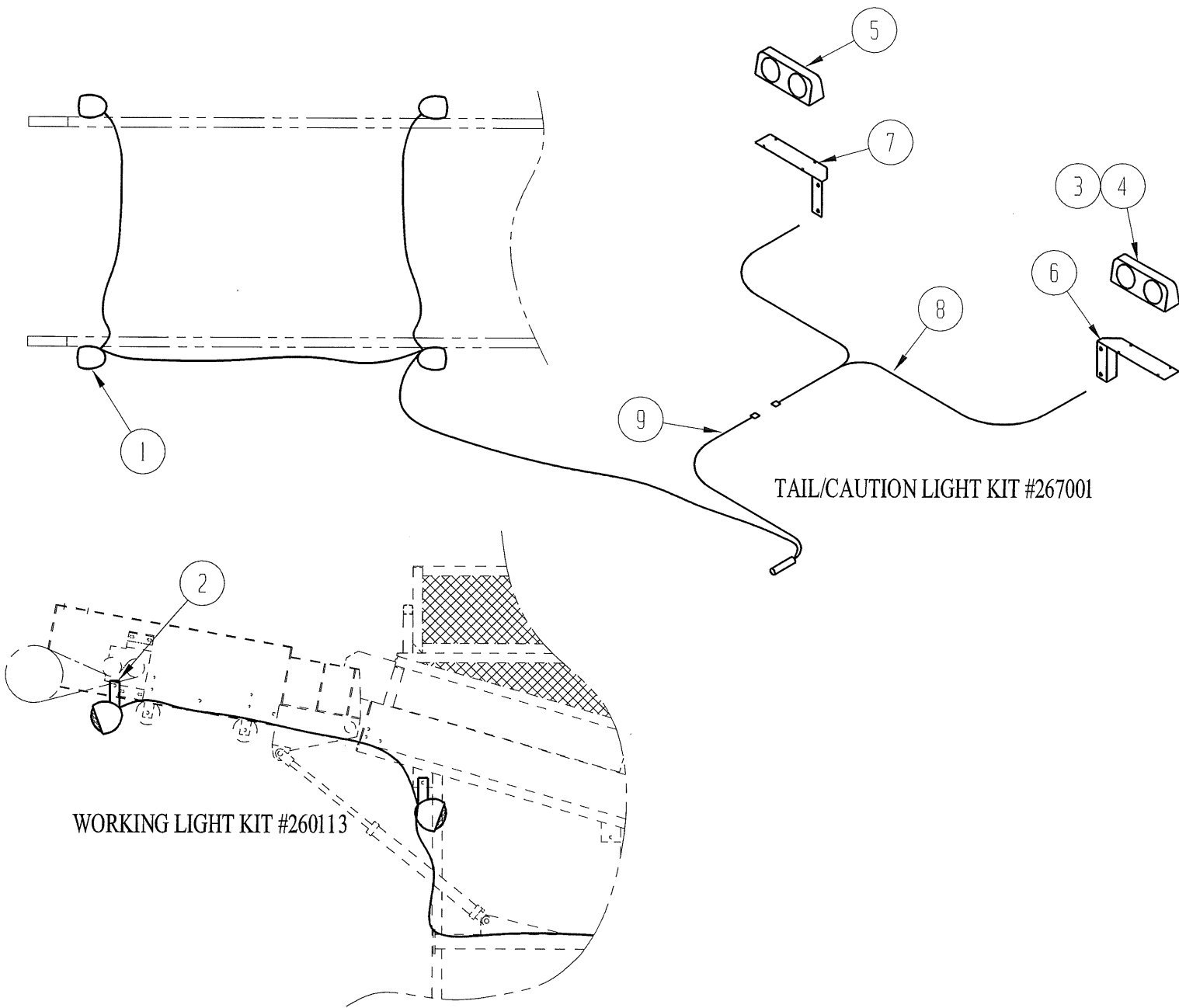

LIGHTING KITS

ITEM NO.	QUANTITY	PART NO.	DESCRIPTION
1	4	265337	Light Assembly
2	4	250111	Mounting Bracket
3	4	521277	Light Bulb #1157
4	1	521271	Dual Light, LH
5	1	521272	Dual Light, RH
6	1	266167	Light Bracket, LH
7	1	266168	Light Bracket, RH
8	1	521275	Wishbone Rear Harness
9	1	521274	Straight Harness, 7 Pin

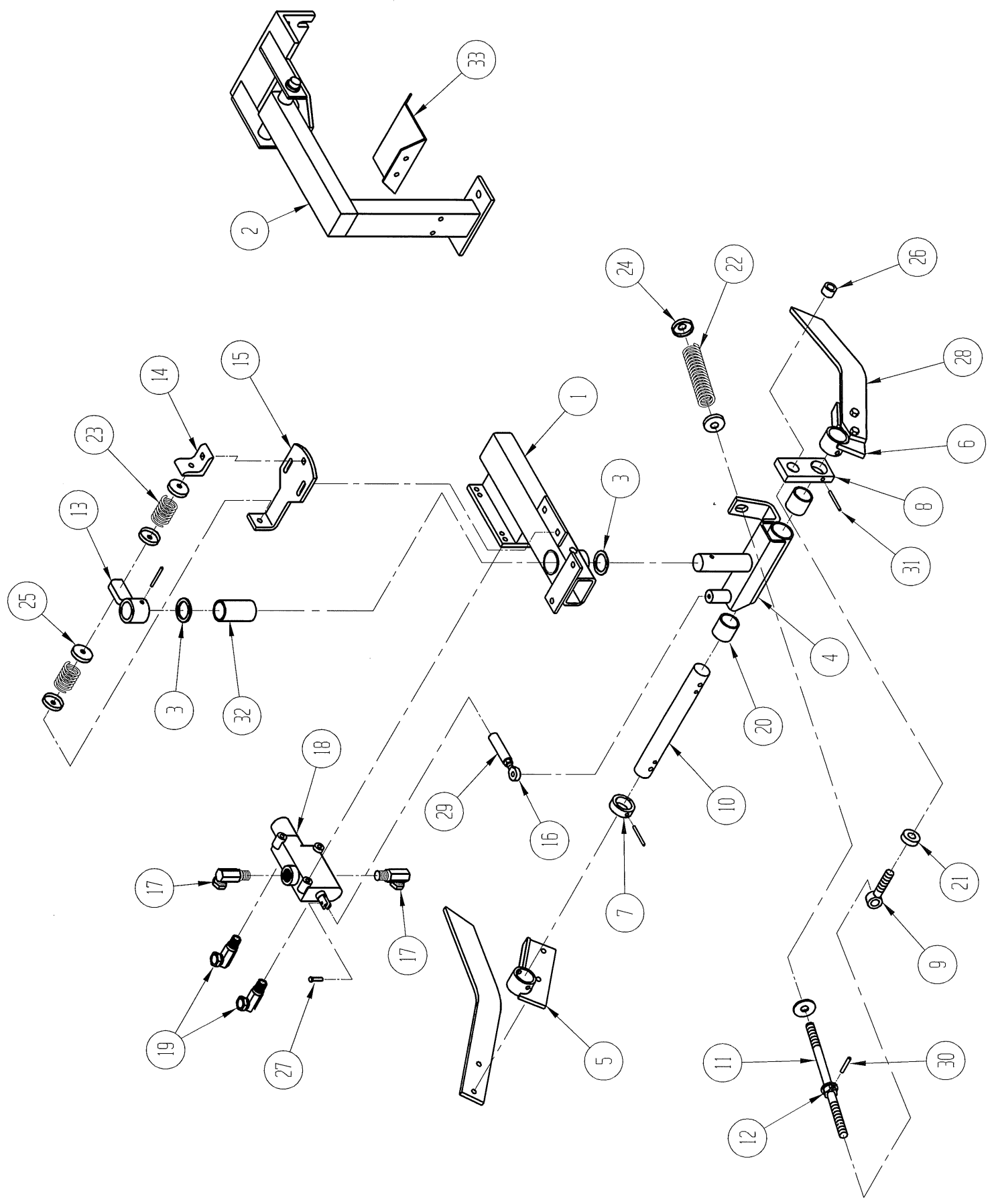

ROW FINDER ASSEMBLY
(#268278)

ITEM NO.	QUANTITY	PART NO.	DESCRIPTION
1	1	266468	Row Finder Body
2	1	268274	Mounting Arm
3	3	998423	Shim
4	1	998236	Control Arm
5	1	998227	Collar (RH)
6	1	998225	Collar (LH)
7	1	998210	Set Collar
8	1	998211	Link Arm Plate
9	1	998607	Rod End Take-up Bolt
10	1	998212	Guide Arm Shaft
11	1	998487	Tension Bolt
12	1	998492	Adjusting Nut
13	1	998484	Control Arm Headpiece
14	1	998490	Tension Plate Bracket
15	1	998483	Tension Plate
16	1	300082	Male Rod End
17	2	2107-12-6	Swivel Elbow, 90° X 3/4 M x 3/8 Female NPT
18	1	903018	Control Valve
19	2	2107-8-6	Swivel Elbow, 90° X 1/2 M x 3/8 Female NPT
20	2	890020	Sleeve Bearing
21	1	998214	Spacer
22	1	998494	Compression Spring
23	2	998493	Compression Spring
24	2	890358	Expansion Plug
25	4	890357	Expansion Plug
26	1	998215	Bushing
27	1	-----	Roll Pin 3/16 x 1
28	2	998224	Fin
29	1	998228	Valve Take-up Bracket
30	1	-----	Roll Pin 1/4 x 1 1/2
31	3	-----	Roll Pin 5/16 x 2
32	1	998230	Bushing
33	1	267156	Cover

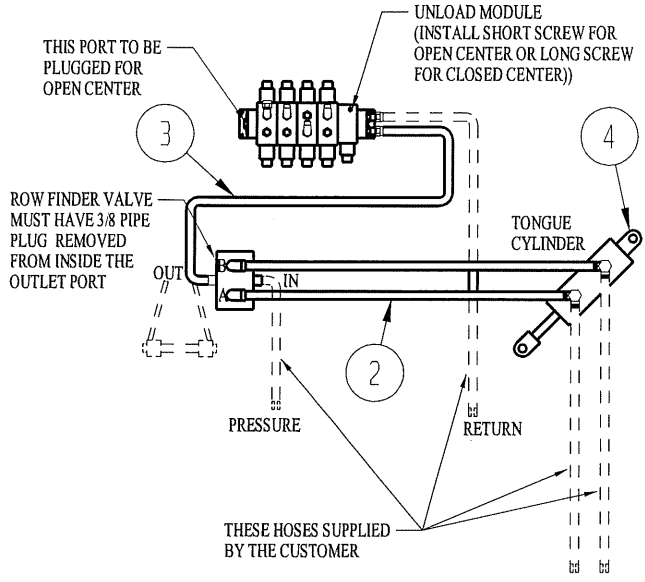

OPEN CENTER HYDRAULICS
PLUMBING USING TRACTOR VALVE OVERRIDE

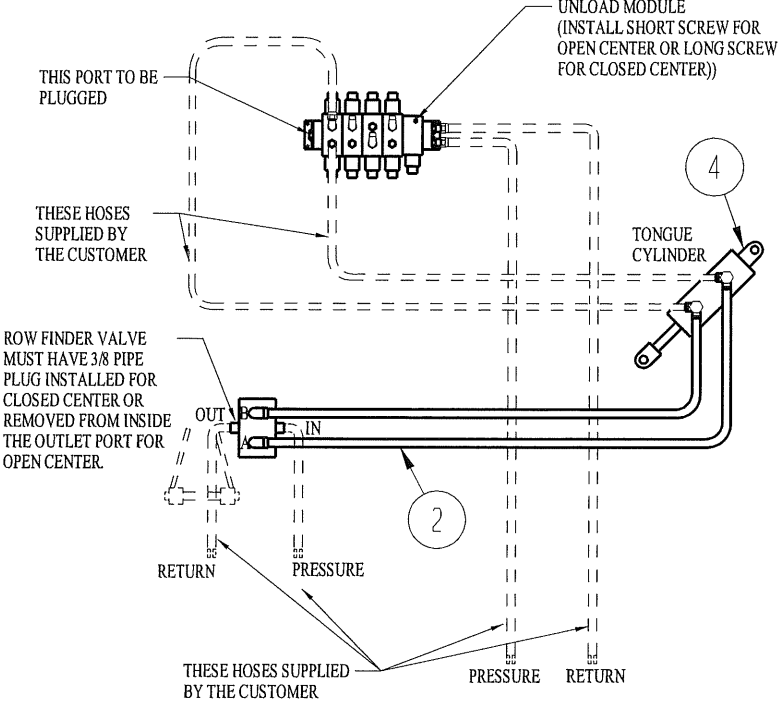

OPEN & CLOSED CENTER HYDRAULICS
PLUMBING USING TRACTOR POWER BEYOND AND VALVE BANK OVER RIDE

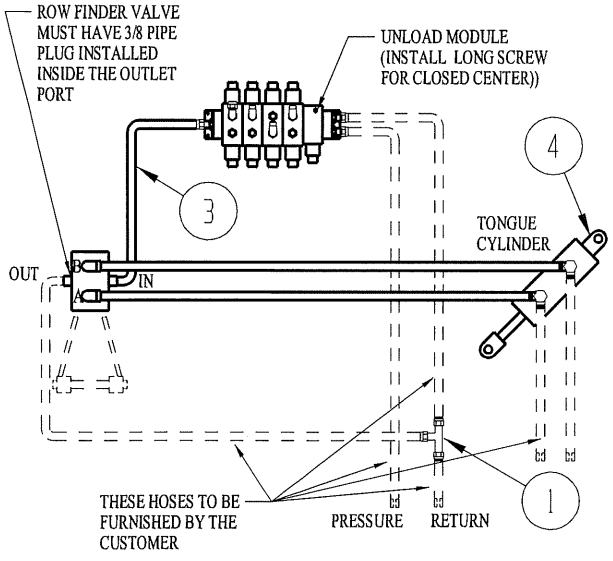

CLOSED CENTER HYDRAULICS
PLUMBING USING TRACTOR VALVE OVERRIDE

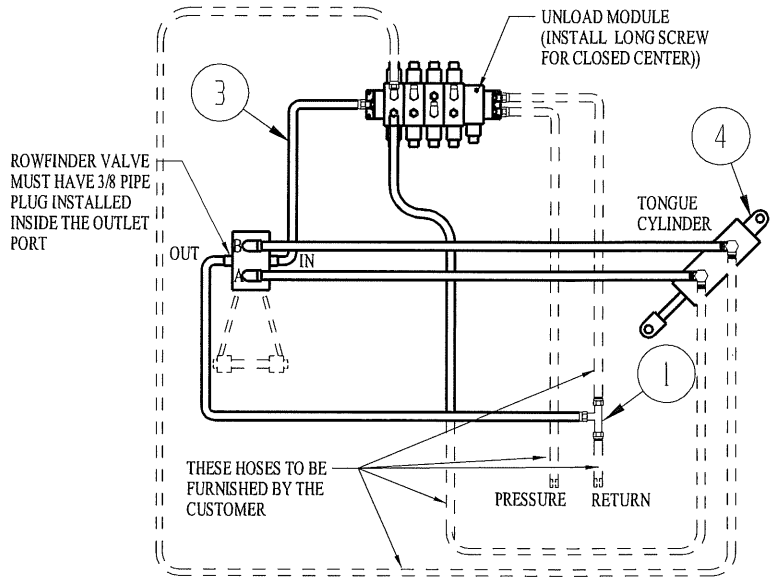

CLOSED CENTER HYDRAULICS
PLUMBING USING VALVE BANK OVERRIDE

THIS PORT TO BE PLUGGED FOR OPEN CENTER

UNLOAD MODULE
(INSTALL SHORT SCREW FOR OPEN CENTER OR LONG SCREW FOR CLOSED CENTER))

ROW FINDER VALVE MUST HAVE 3/8 PIPE PLUG REMOVED FROM INSIDE THE OUTLET PORT.

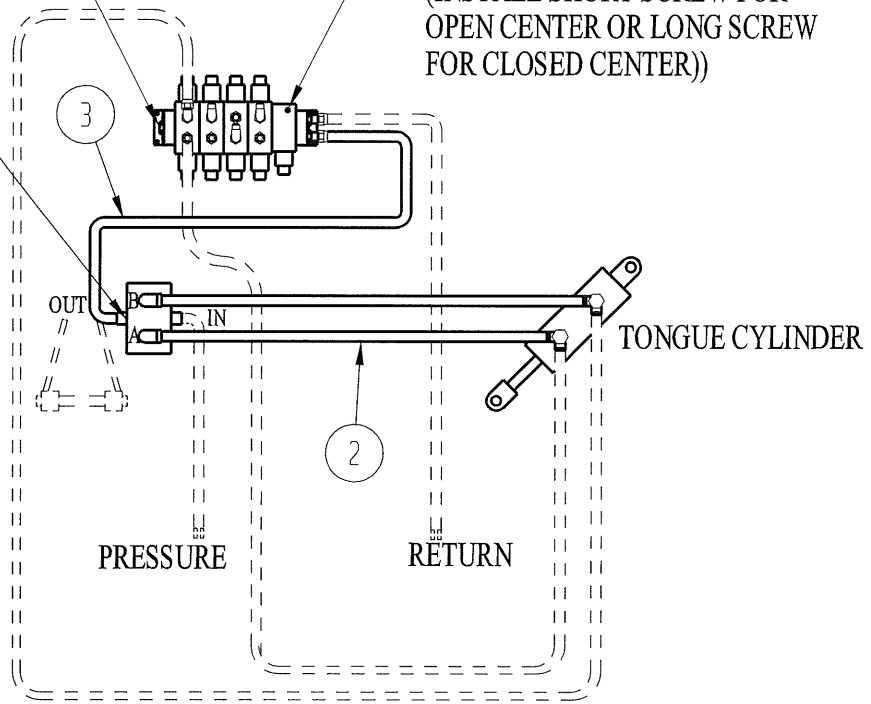

**OPEN CENTER HYDRAULICS
PLUMBING USING VALVE BANK OVERRIDE**

NOTE:
ALL UNIDENTIFIED HYDRAULIC HOSES
ARE TO BE FURNISHED BY THE CUSTOMER.

**ROW FINDER HYDRAULICS
OPEN/CLOSED CENTERS
Pages 38 and 39**

ITEM NO.	QUANTITY	PART NO.	DESCRIPTION
1	1	C5705-8	Union Tee, 1/2 X 1/2 JIC
2	2	902105	Hydraulic Hose, 1/2 x 42 w/ 1/2 Male Pipe Ends
3	1	902107	Hydraulic Hose, 3/8 x 96 w/ 3/8 Male Pipe Ends
4	1	998940	Hydraulic Cylinder 3 1/2 x 8

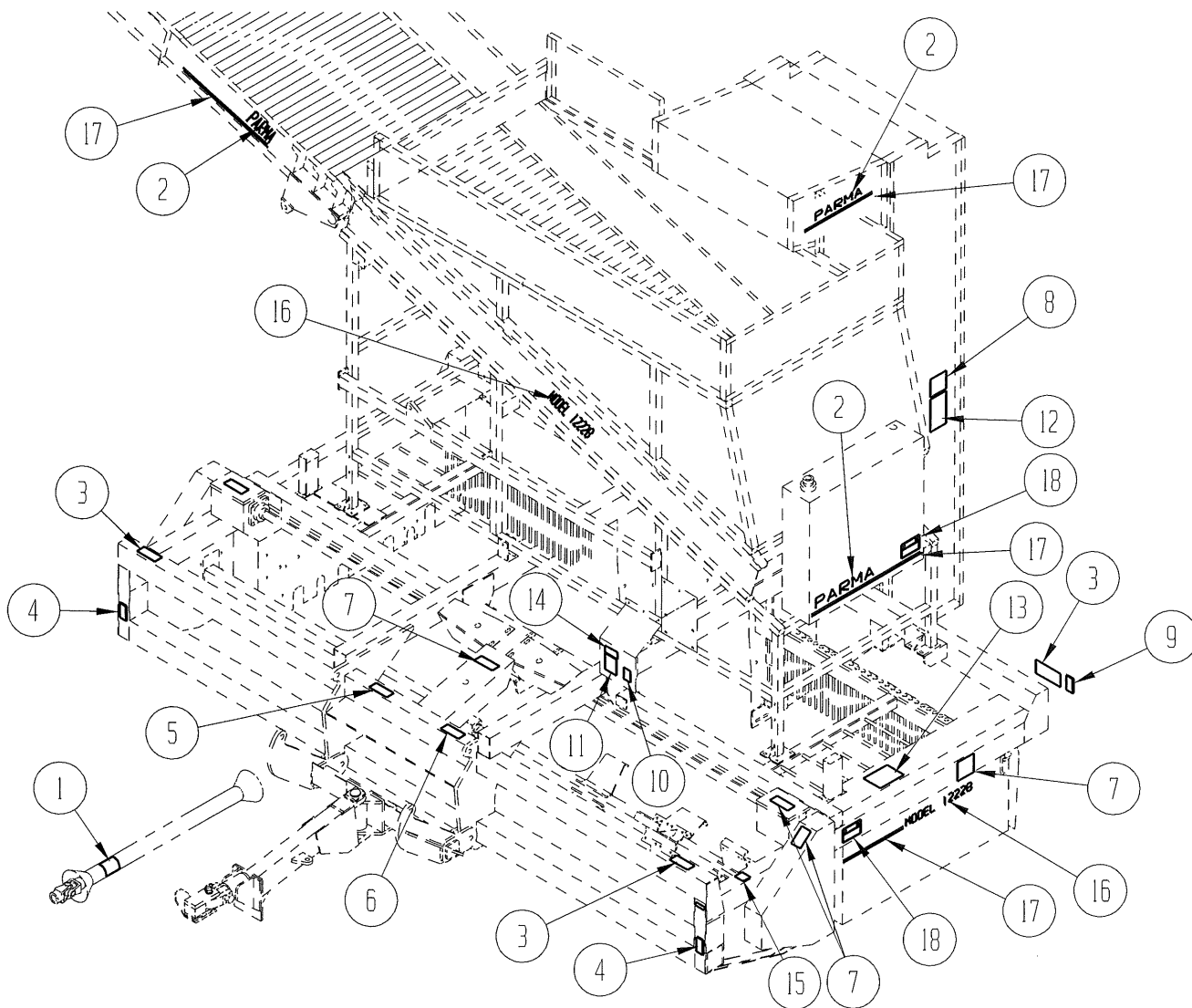

DECAL GROUP

ITEM NO.	QUANTITY	PART NO.	DESCRIPTION
1	1	990798	Decal, PTO Safety
2	5	264797	Decal, Parma
3	4	100404	Decal, Blocking
4	2	264515	Amber Reflector
5	2	100407	Decal, Safety Chain
6	1	100566	Decal, Maximum Speed
7	6	100409	Decal, Guard in Place
8	2	100311	Decal, Rotating Parts
9	2	264516	Red Reflector
10	1	100423	Decal, FEMA
11	1	100406	Decal, General Cautions
12	1	100746	Decal, Elevator Diagram
13	2	100403	Decal, Grab Roll Caution
14	1	100408	Decal, Hydraulics Pressurized
15	1	100748	Decal, Patent Pending
16	3	268690	Decal, Model 29683
	3	268556	Decal, Model 12228
17	Approx. 30'	264798	Double Stripe Tape
18	2	265933	Decal, Danger Do Not Ride

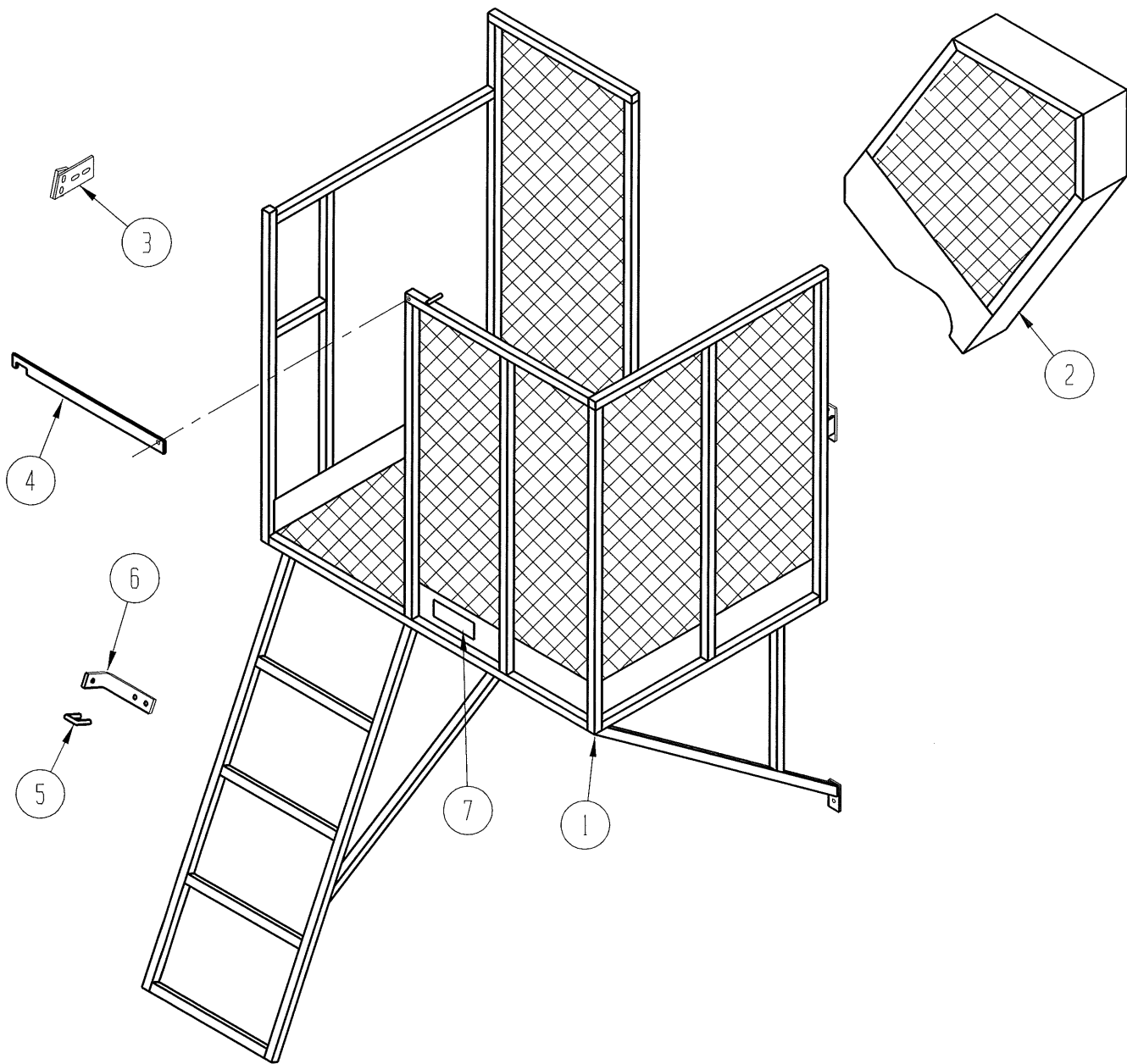

PLATFORM ASSEMBLY

ITEM NO.	QTY	PART NO.	PART NO.	DESCRIPTION
		2966	2980 Series	
1	1	267999	266517	Platform
2	1	267998	267998	Elevator Drive Cover
3	1	267993	267993	Ladder Bracket, Bottom
4	1	266445	266445	Latch
5	2	266520	266520	U-Bolt
6	1	267992	267992	Ladder Bracket, Top
7	1	265933	265933	Decal, Danger

SWITCH BOX 15 POSITION CONNECTOR PIN NUMBERS/COLORS

PIN#	COLOR	FUNCTION	PIN#	COLOR	FUNCTION
1	ORANGE	NOT USED	9	BLACK/RED	STEER RIGHT
2	ORANGE/BLK	NOT USED	10	RED	STEER RIGHT
3	GREEN	NOT USED	11	RED/BLACK	UNLOAD VALVE
4	BROWN/BLK	NOT USED	12	ORANGE/RED	OVER RIDE
5	BLUE	BOOM UP	13	YELLOW/BLK	OVER RIDE
6	BLUE/BLK	BOOM DOWN	14	BLACK/WHITE	NOT USED
7	BLUE/RED	STEER LEFT	15	YELLOW	GROUND
8	BLACK	STEER LEFT			

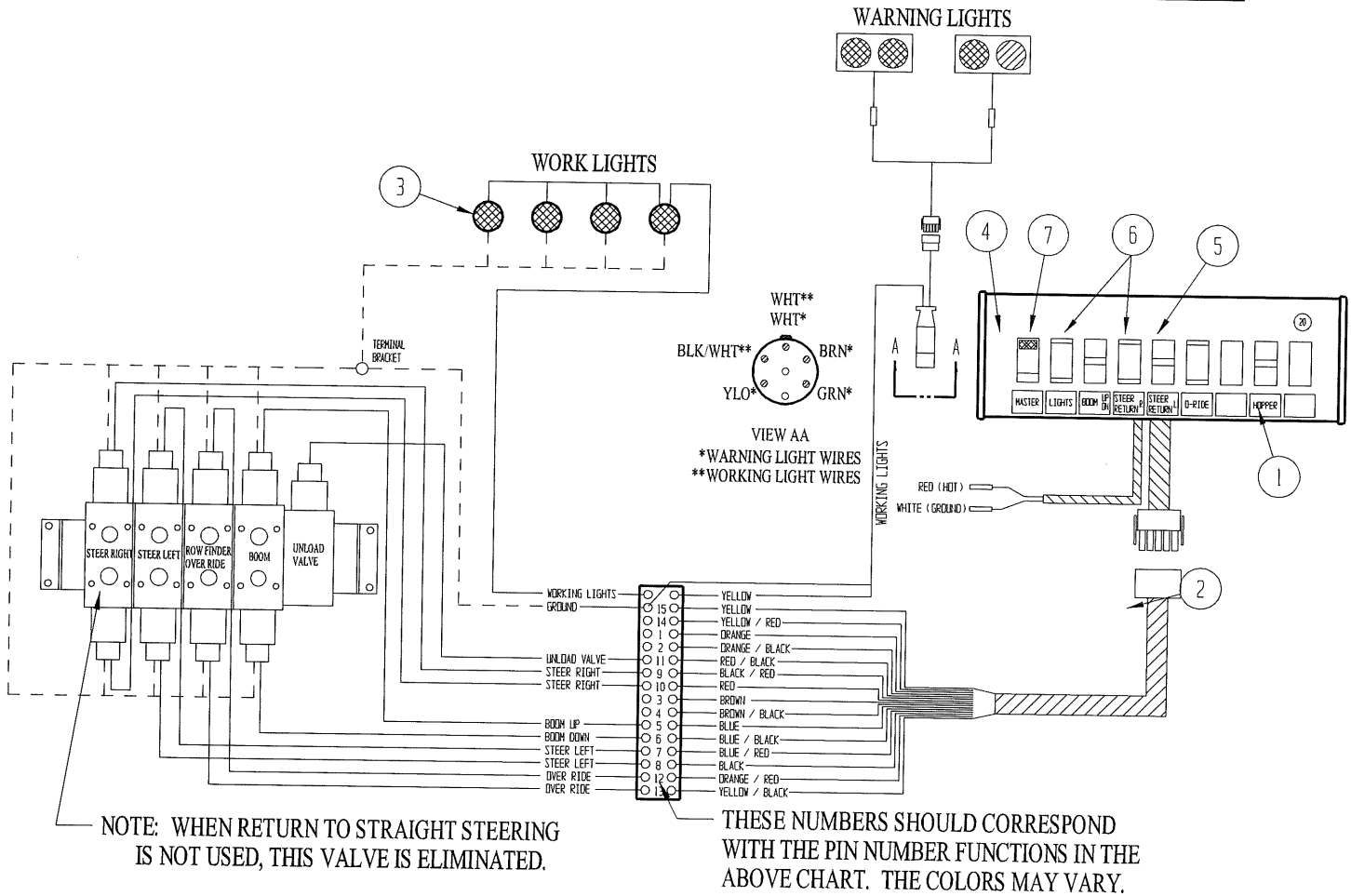

WIRING SCHEMATIC

ITEM NO.	QUANTITY	PART NO.	DESCRIPTION
1	1	264543	Switch Box
2	1	264546	15 Wire Cable
3	1	-----	Light Kit
4	1	264895	Master Switch
5	2	264896	Momentary Switch
6	2	265357	Toggle Momentary Switch
7	1	264897	On-Off Switch

GEAR BOX ASSEMBLY 1.93:1
267171

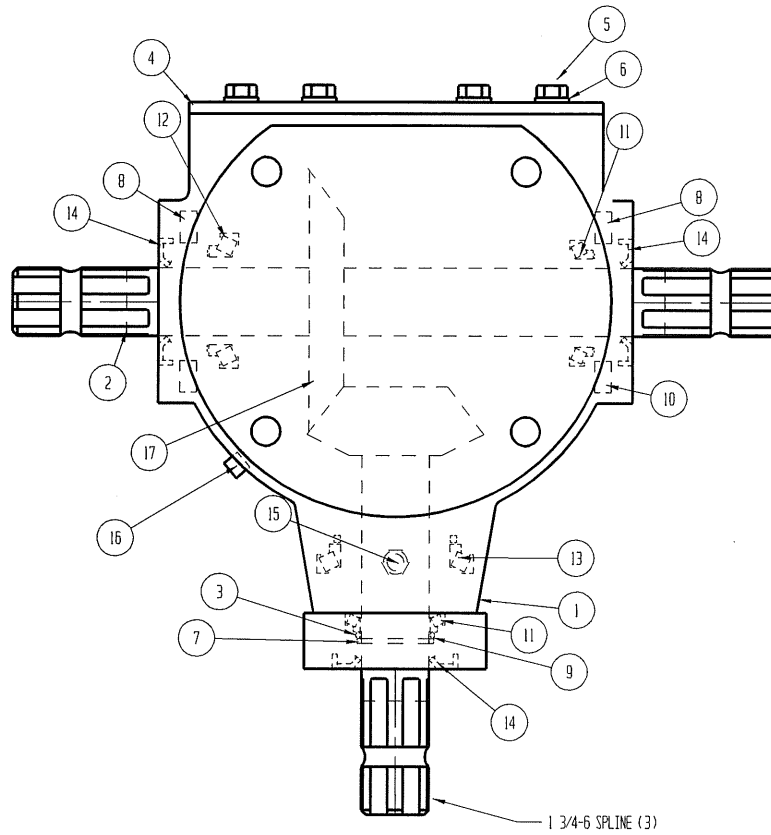

ITEM #	PARMA PART#	DESCRIPTION	BONDOLI PART #
1	267733	GEARBOX SHELL	290291301
2	267734	SHAFT	295044019
3	267735	SPACER	298405025
4	267736	COVER	298625400
5	267737	SCREW	319012200
6	267738	WASHER	335010001
7	267739	SNAP RING	339000050
8	267740	SNAP RING	339000090
9	267741	RING	340E05000
10	267742	RING	340I09000
11	267743	TAPERED R. BEARING	354400050
12	267744	BEARING	354401050
13	267745	BEARING	354405050
14	267746	OIL SEAL	355020050
15	267747	OIL PLUG	373007000
16	267748	OIL PLUG	373010000
17	267749	BEVEL GEAR	448193710

NOTES