

# ***PARMA***<sup>®</sup>

---

## **M-S & Chopper Pump**

### **SERVICE & PARTS MANUAL**

Date of Manufacture: \_\_\_\_\_ Serial# \_\_\_\_\_

Manual Number 06012012-PMP

---

***PARMA***  
***COMPANY***

P.O. BOX 190

PARMA, IDAHO 83660

PHONE (208) 722-5116 FAX (208) 722-6012

Website: [www.parmacompany.com](http://www.parmacompany.com)

E-Mail: [parmacom@parmacompany.com](mailto:parmacom@parmacompany.com)



## TABLE OF CONTENTS

ASSEMBLY INSTRUCTIONS.....	7
BELT TENSIONING.....	16
COLUMN AND SHAFT REQUIREMENTS .....	10
FINAL ASSEMBLY.....	14
INTRODUCTION.....	1
LUBRICATION.....	15
MAINTENANCE/SERVICE INFORMATION.....	15
PARTS REPLACEMENT SECTION .....	18
PRELIMINARY INSPECTION, CHOPPER BOWL ASSEMBLY.....	8
PRELIMINARY INSPECTION, M-S BOWL ASSEMBLY.....	7
PRELIMINARY INSPECTION, PUMP UNITS.....	9
PUMP INSTALLATION.....	15
PUMP UNIT ASSEMBLY .....	10
SAFETY PRECAUTIONS .....	3
SHEAR HUB ADJUSTMENT .....	15
SPREADER BRACKET REQUIREMENTS.....	13
TROUBLE SHOOTING .....	17
WARRANTY POLICY .....	2



# INTRODUCTION

The **Parma Water Lifter** has been manufactured since 1907. This means you can have confidence in our products based on the many years of reliable performance from **Parma Pumps**. Their simplicity of design and quality construction makes them virtually trouble free pumps that are adaptable to almost any job in agriculture or industry where liquids and semi-liquids need to be moved.

The **Parma Pump** is a submerged type of centrifugal pump, which stands in the liquid it is pumping. This fact makes it possible to eliminate the suction pipe, foot valve, strainer and packing gland found in most pumps of this type. Since the **Parma Pump** does not require a vacuum inside the bowl, all of these troublesome parts have been left out of its design. It also produces more reliable operation, as weeds, trash, sewage wastes, manufacturing wastes, etc., can pass right through the pump without causing damage or obstructing the flow.

The purpose of this manual is to assist the dealer or owner in assembly and repair of the pumps.

## WARRANTY POLICY

PARMA COMPANY warrants to each purchaser from an authorized dealer of new equipment manufactured by PARMA COMPANY, that such equipment is, at the time of delivery to such purchaser, free from defects in material and workmanship under normal use, if serviced in accordance with the recommendations of the Operator's Manual. All PARMA COMPANY'S *harvesting equipment products* are warranted for 120 days from the first day of use or 800 acres, whichever occurs first. All PARMA COMPANY *soil preparation* products are warranted for 120 days from first day of use or 1600 acres, whichever occurs first. All PARMA COMPANY *water and waste pump products* are warranted for one year from date of purchase. ALL PARMA COMPANY *forage products* are warranted for one year from date of purchase. Warranty on defective parts purchased by PARMA COMPANY or produced by other manufacturers for PARMA COMPANY may be allowed only after the approval of the vendor or manufacturer.

PARMA COMPANY'S obligation under this warranty is limited to repairing, or at it's option, replacing any part, that in PARMA COMPANY'S judgment, proved defective. Under the terms of the warranty, PARMA COMPANY assumes no responsibility for labor or travel costs involved in removal of defective parts, of installation of new parts, or of any shop supplies or service charges.

All warranty claims are to be initiated through the authorized PARMA COMPANY dealer and **must be submitted within 30 days of the date of failure**. PARMA COMPANY may ask for defective parts to be returned to the factory; therefore, hold all warranty claim parts until advised if the parts are needed by your dealer.

To make the warranty effective, the owner's **Warranty Registration Form** must be on file at PARMA COMPANY, Parma, Idaho at the time of receipt of the warranty claim.

## DISCLAIMER OF ALL OTHER WARRANTIES AND CONSEQUENTIAL DAMAGES

THE FOREGOING IS IN LIEU OF ALL OTHER WARRANTIES, WHETHER EXPRESSED OR IMPLIED, INCLUDING ANY IMPLIED WARRANTY OF MERCHANTABILITY OR FITNESS FOR A PARTICULAR PURPOSE, AND THERE ARE NO WARRANTIES, WHICH EXTEND BEYOND THE DESCRIPTION OF THE PRODUCTS. THE LIABILITY OF PARMA COMPANY IS EXPRESSLY LIMITED TO REPAIRING, OR AT ITS OPTION, REPLACING ANY PART THAT IS RETURNED, TRANSPORTATION PREPAID, TO PARMA COMPANY, PARMA, IDAHO, THAT IN PARMA'S JUDGEMENT PROVED DEFECTIVE DURING THE WARRANTY PERIOD. NO REPRESENTATIVE OF PARMA COMPANY, NO DEALER OR DEALER'S REPRESENTATIVE OR ANY OTHER PERSON HAS AUTHORITY TO WAIVE, ALTER, VARY OR ADD TO THE TERMS HEREOF WITHOUT PRIOR APPROVAL IN WRITING SIGNED BY AN OFFICER OF PARMA COMPANY. PARMA COMPANY WILL NOT BE LIABLE FOR ANY OTHER EXPENSE, INJURY, LOSS OR DAMAGE WHETHER DIRECT OR CONSEQUENTIAL, ARISING IN CONNECTION WITH THE SALE OR USE OF OR INABILITY TO USE, ANY PRODUCT OF THE COMPANY FOR ANY PURPOSE.

# SAFETY PRECAUTIONS

**TAKE NOTE! THIS SAFETY ALERT SYMBOL FOUND THROUGH OUT THIS MANUAL IS USED TO CALL YOUR ATTENTION TO INSTRUCTIONS INVOLVING YOUR PERSONAL SAFETY AND THE SAFETY OF OTHERS. FAILURE TO FOLLOW THESE INSTRUCTIONS CAN RESULT IN INJURY OR DEATH.**



**THIS SYMBOL MEANS**

**-ATTENTION!**

**-BECOME ALERT!**

**- YOUR SAFETY IS INVOLVED!**

## **SIGNAL WORDS:**

Note the use of the signal words **DANGER**, **WARNING** and **CAUTION** with the safety messages. The appropriate signal word for each has been selected using the following guidelines:

**DANGER:** Indicates an imminently hazardous situation that, if not avoided, will result in death or serious injury. This signal word is to be limited to the most extreme situations typically for machine components for which functional purposes cannot be guarded.

**WARNING:** Indicates a potentially hazardous situation that, if not avoided, could result in death or serious injury, and includes hazards that are exposed when guards are removed. It may also be used to alert against unsafe practices.

**CAUTION:** Indicates a potentially hazardous situation that, if not avoided, may result in minor or moderate injury. It may also be used to alert against unsafe practices.

If you have questions not answered in this manual or require additional copies or the manual is damaged, please contact your dealer.

**SAFETY.... YOU CAN LIVE WITH IT**



## **SAFETY.... YOU CAN LIVE WITH IT!**



### **PUMP OPERATION SAFETY GUIDELINES**

Safety of the operator is one of the main concerns in designing and developing a new piece of equipment. Designers and manufacturers build in as many safety features as possible. However, every year many accidents occur which could have been avoided by a few seconds of thought and a more careful approach to handling equipment. You, the operator, can avoid many accidents by observing the following precautions in this section. To avoid personal injury, study the following precautions and insist those working with you, or for you, follow them.

In order to provide maximum safety to the operator or other persons around this machine, various shields and covers have been installed. Keep all shields and covers in place. If shield removal becomes necessary for repairs or any other reason, replace the shield prior to use.

Replace any CAUTION, WARNING, DANGER or instruction safety decal that is not readable or is missing.

Do not attempt to operate this equipment under the influence of drugs or alcohol.

This equipment is dangerous to children and persons unfamiliar with its operation. The operator should be a responsible adult familiar with farm machinery and trained in this equipment's operations. **Do not allow persons to operate or assemble this unit until they have read this manual and have developed a thorough understanding of the safety precautions and of how it works.**

Do not paint over, remove or deface any safety signs or warning decals on your equipment. Observe all safety signs and practice the instructions on them.



### **REMEMBER!**

**Your best assurance against accidents is a careful and responsible operator. If there is any portion of this manual or function you do not understand, contact your local authorized dealer or the manufacturer.**



### **BEFORE OPERATING:**

- Carefully study and understand this manual
- Do not wear loose-fitting clothing which may catch in moving parts
- Always wear protective clothing and substantial shoes
- Inspect the unit for any loose bolts, worn parts or cracked welds, and make necessary repairs. Follow the maintenance safety instructions included in this manual
- Do not use the unit until you are sure that the area is clear, especially children and animals



- Don't hurry the learning process or take the unit for granted. Ease into it and become familiar with you new equipment



### **DURING OPERATION:**

- Keep hands and clothing clear of moving parts
- Disconnect power source to adjust or service
- Make certain everyone is clear of equipment before applying power
- Disconnect power before resetting motor overload
- Keep all pit openings covered when not in use
- Do not clean, lubricate or adjust your equipment while it is in motion
- As a precaution, always recheck the hardware on equipment following every 100 hours of operation. Correct all problems. Follow the maintenance safety procedures



### **DANGER!**

- **BE AWARE OF MANURE GAS IN PIT.** Liquid manure produces **DANGEROUS GASES THAT CAN BE FATAL!**
- **Do not** attempt to agitate liquid manure unless the ventilation system is in full operation and/or windows and doors are all open. Gases are more apt to be disseminated during the agitation than during the pumping period.
- **Do not** enter a liquid manure tank of any type unless you have a special breathing apparatus. In addition, a rope should be tied around the waist and held by a person outside the danger area so that if the person is overcome by the poisonous gasses or from the lack of oxygen, he may be pulled to safety without his rescuers also being overcome.
- If an operator does feel faint, get him out into the fresh air and give him artificial respiration if required.
- Use portable fans to expel gases and replace them with fresh air.
- Reduce possible danger to livestock by using a two-fan system of ventilation. The small fan should operate continuously while the large one is controlled by a thermostat.

**CONCLUSION:** We recommend that all operators of liquid manure equipment familiarize themselves with gas problems.



### **PERFORMING MAINTENANCE:**

- Good maintenance is your responsibility. Poor maintenance is an invitation to trouble
- Be certain all moving parts have come to a complete stop before attempting to perform maintenance
- Always use the proper tools or equipment for the job at hand
- Use extreme caution when making adjustments
- Replace **all shields and guards** after servicing and before moving
- After servicing, be sure all tools, parts and service equipment are removed
- Never replace hex bolts with less than grade five bolts unless otherwise specified.
- Where replacement parts are necessary for periodic maintenance and servicing, genuine factory replacement parts are recommended to restore your equipment to original specifications. The manufacturer will not claim responsibility for use of unapproved parts and/or accessories and other damages as a result of their use
- If equipment has been altered in any way from original design, the manufacturer does not accept any liability for injury or warranty



**SAFETY... YOU CAN LIVE WITH IT**

# ASSEMBLY INSTRUCTIONS

Before assembling your new Parma Pump, check the parts received with the packing slip to assure that you have received the required parts. Check all parts for damage, which may have occurred during shipment. Damaged shafts or columns will cause premature bearing failure, and a damaged bowl assembly can cause unsatisfactory operation of your pump. Keep all parts clean and protected during assembly. All pumps are to be assembled in the horizontal position, taking care not to damage machined surfaces. Parma pumps will give many years of trouble free service if the parts are cared for at the time of assembly and the pump is assembled correctly. Please follow these instructions to prevent future problems.

## PRELIMINARY INSPECTION:

### M-S Bowl Assemblies

1. Remove pump bowl assembly from the shipping crate, taking care not to drop the assembly.



**CAUTION; KEEP FINGERS OUT OF BOWL INLETS TO PREVENT SERIOUS INJURY!**

2. Check all bolts and set screws to assure they are tight.
3. Check impeller clearance at top and bottom bowl cases. The impeller should be located in the center of the bowl as shown in Figure 1, such that the clearance from the impeller to the top bowl is the same as the clearance of the impeller to the bottom bowl.

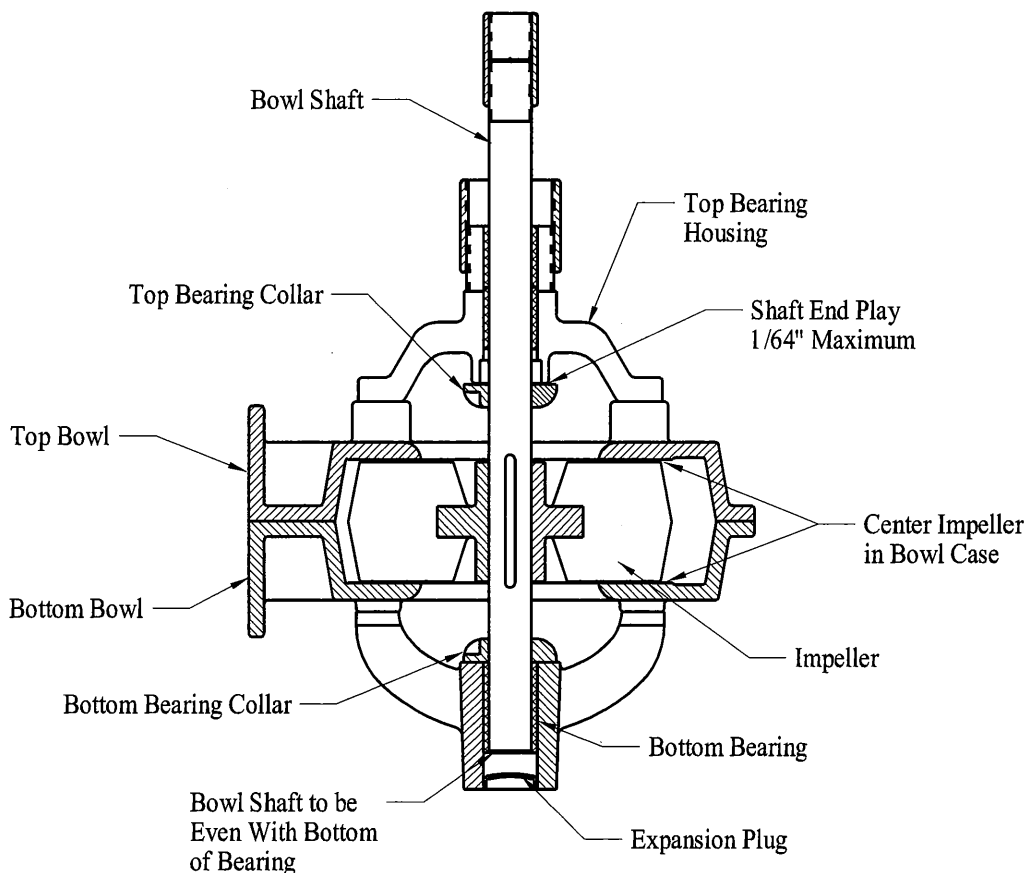

FIGURE 1.

4. If adjustment is required for centering the impeller, follow these steps (See Figure 1).
  - Remove the expansion plug.
  - Loosen the setscrews in the impeller and bearing collars.
  - Adjust the bowl shaft until the shaft end meets the lower end of the bearing in the bottom bearing housing.
  - Center the impeller in the bowl (take care not to change the bowl shaft location).
  - Tighten the setscrews in the impeller. For best results, tighten the setscrews, loosen them, and tighten them again to assure that they are seated into the bowl shaft.
  - Set the bearing collars against the bearing housings to allow pump shaft total endplay not to exceed 1/64".
  - Tighten the setscrews in each bearing collar when adjustments are complete. The bearings are lubricated at the factory and do not require further lubrication.
  - Press the expansion plug into the bottom bearing housing until it is flush with the end of the housing.
5. The pump bowl assembly is now ready for column and shafts to be installed.

### **Chopper Bowl Assemblies**

1. Remove chopper bowl assembly from the shipping crate, taking care not to drop the assembly.



**CAUTION, KEEP FINGERS OUT OF SHEAR HOUSING TO PREVENT SERIOUS INJURY!**

2. Check all bolts and set screws to assure they are tight. Do not over tighten bolts since they can damage castings.
3. Check shear hub to shear blade clearance. **With the impeller positioned to have 1/16" clearance from the bottom bowl, and the shear hub touching the top of the impeller, the shear hub to shear blade clearance should be 0.002" to 0.004".**
4. If adjustment is required to obtain this clearance, follow these steps (See Figure 2).
  - Loosen the setscrews in the shear hub and impeller.
  - Remove the expansion plug in the bottom of the bearing housing.
  - Adjust the bowl shaft until the shaft end meets the lower end of the bearing in the bottom bearing housing, as shown in Figure 3.
  - Lift the impeller along the bowl shaft until the impeller clears the bottom bowl 1/16" (take care not to change the bowl shaft location).
  - Check the bowl shaft end again to assure that it aligns with the bottom of the bearing in the bottom bearing housing.
  - Tighten the setscrews in the impeller. For best results, tighten the setscrews, loosen them, and tighten them again to assure that they are seated into the bowl shaft.
  - Lower the shear hub on the bowl shaft until it rests on top of the impeller.
  - Tighten the setscrews in the shear hub following the previous mentioned sequence.
  - Adjust the four shear blades by loosening the cap screws in each blade and sliding the blades in toward the shear hub until they contact the cutter. Then slide the blades back slightly to obtain 0.002" to 0.004" clearance. When all the blades are secured, the clearance should be checked again.
  - Press the expansion plug into the bottom bearing housing until it is flush with the end of the housing.
  - Remove any foreign material from the shear housing and pump bowl.
  - The chopper bowl assembly is now ready for column and shafts to be installed.

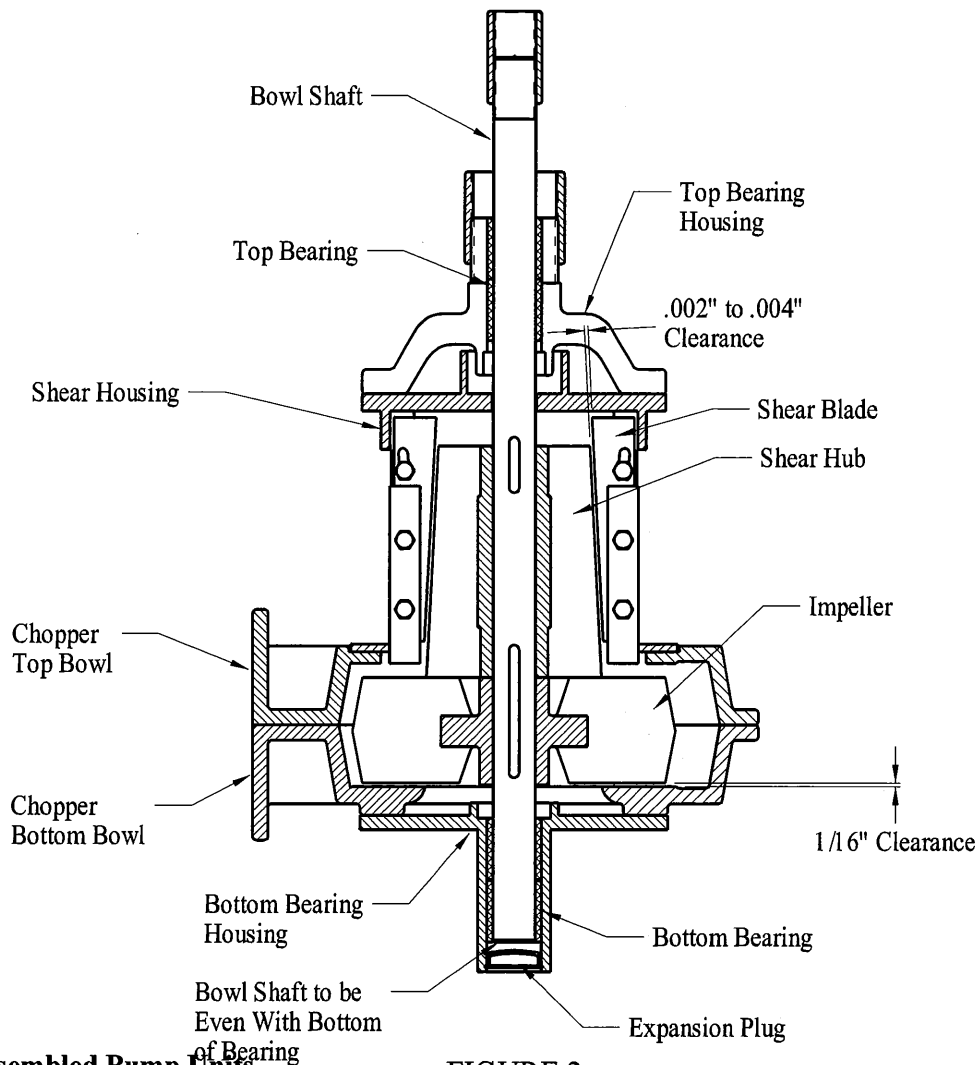

FIGURE 2.

**Factory Assembled Pump Units**

Factory assembled pump units should be adjusted and ready for operation. Remove all banding straps and blocks used in shipment.



**CAUTION, USE HEAVY GLOVES AND EYE PROTECTION WHEN REMOVING BANDING MATERIAL.**

The following checks should be made to assure the pump is operable after shipment.

1. Check all bolts to assure they are tight. Do not over tighten bolts since they can damage castings.
2. Check the setscrews in the impeller (and shear hub on chopper pumps) to assure they are tight.
3. Make sure the pump shaft turns freely.



**CAUTION; KEEP FINGERS OUT OF BOWL INLETS TO PREVENT SERIOUS INJURY!**

4. Check impeller clearance in the bowl cases. Refer to M-S and Chopper bowl assembly check lists (Figures 1 & 2) for clearance instructions. If adjustments are required, loosen the set screws in the set collar (adjusting nut on chopper pumps) at the top drive bearing housing, then follow the same steps as listed for the M-S and Chopper bowl assemblies.

## **PUMP UNIT ASSEMBLY:**

**NOTE: Be sure the initial inspection and necessary adjustments are made before proceeding to the final assembly of the pump.**

1. Before assembling columns and shafts, check all machined surfaces to damage, which can cause damage to couplings and require replacement of other components.
2. Lay all columns and shafts on a clean surface. The table below indicates the required drive column and shaft assemblies and the required number of intermediate column and shaft assemblies for each setting (length) in which the pumps are available.

COLUMN AND SHAFT REQUIREMENTS		
PUMP SETTING LENGTH	DRIVE COLUMN AND SHAFT ASSEMBLY	INTERMEDIATE COLUMN AND SHAFT ASSEMBLY
4 Ft.	1 SHORT	-
6 Ft.	1 LONG	-
8 Ft.	1 SHORT	1 INTERMEDIATE
10 Ft.	1 LONG	1 INTERMEDIATE
12 Ft.	1 SHORT	2 INTERMEDIATE
14 Ft.	1 LONG	2 INTERMEDIATE
16 Ft.	1 SHORT	3 INTERMEDIATE
18 Ft.	1 LONG	3 INTERMEDIATE
20 Ft.	1 SHORT	4 INTERMEDIATE

3. Set aside the column with a 3/8" threaded hole and 3/16 hole in the side. This is the drive column.
4. Locate the column shaft without threads on one end (the drive shaft), and place with the drive column. All other columns and shafts are to be assembled in intermediate positions in the setting. Each intermediate column requires one column coupling and one column bearing. Each intermediate shaft requires one shaft coupling.
5. Always assemble the pump taking care not to bend the columns or shafts.
6. Thread one shaft coupling onto the bowl shaft until the coupling is threaded halfway on the shaft. Use the witness hole in the shaft coupling to assure that the coupling is half way on the bowl shaft. See Figure 3.
7. Thread one intermediate shaft into the shaft coupling, taking care not to move the coupling. Tighten the shafts, taking care not to score the shaft with wrenches.
8. Check to make sure the column coupling is halfway onto the top bearing housing.
9. Thread one intermediate column into the column coupling, taking care to assure the coupling is threaded halfway onto the column and halfway onto the top bearing housing. Tighten the column and bearing housing into the coupling.
10. Follow the same procedure for all intermediate column and shaft assemblies as shown in Figure 4. Be sure the column bearings are threaded to the couplings and centered in the couplings.
11. Thread a shaft coupling onto the last intermediate shaft until coupling is halfway on shaft. Use the witness hole in the shaft coupling to assure that the coupling is half way on the bowl shaft. See Figure 5.
12. Locate the column drive shaft without threads on one end (M-S Pump), or with threads and 1/2" key on one end (Chopper Pump). Thread the end of the drive shaft into the last shaft coupling, taking care not to move the coupling. Tighten the shafts together (don't score the shaft).
13. Thread a column bearing into the last column coupling, centering it in the coupling.
14. Locate the drive column (with two holes) and thread the drive bearing assembly onto the end with the 3/16" vent hole. See Figure 6.

15. Locate the drive base and slide the drive column and drive bearing assembly into the drive base with the rotation arrow facing the drive bearing assembly. Bolt the drive base to the drive bearing assembly using three 1/2" x 2" hex bolts. NOTE: The six holes in the base and bearing assembly allow for aligning the drive base to the pump mounting frame when the discharge pipe is attached.

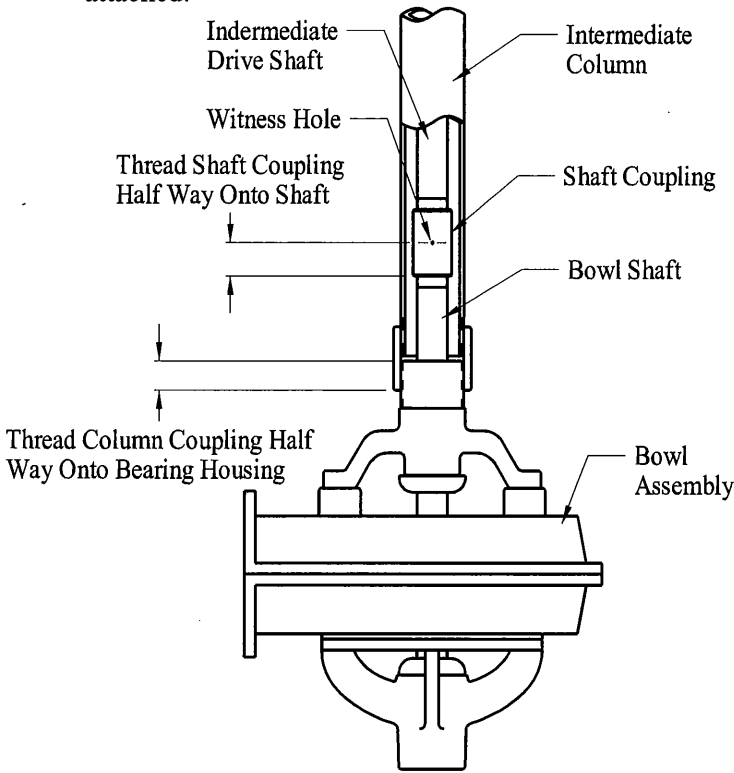

FIGURE 3.

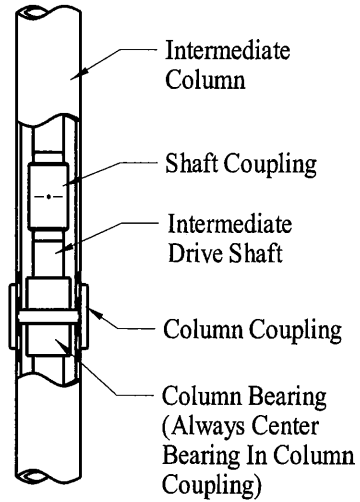

FIGURE 4.

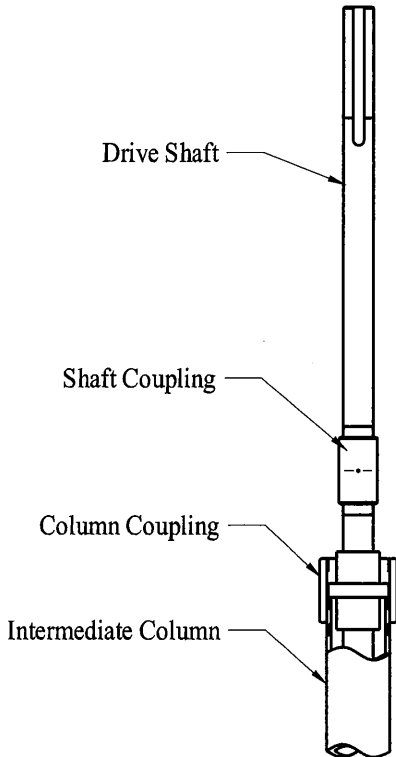

FIGURE 5.

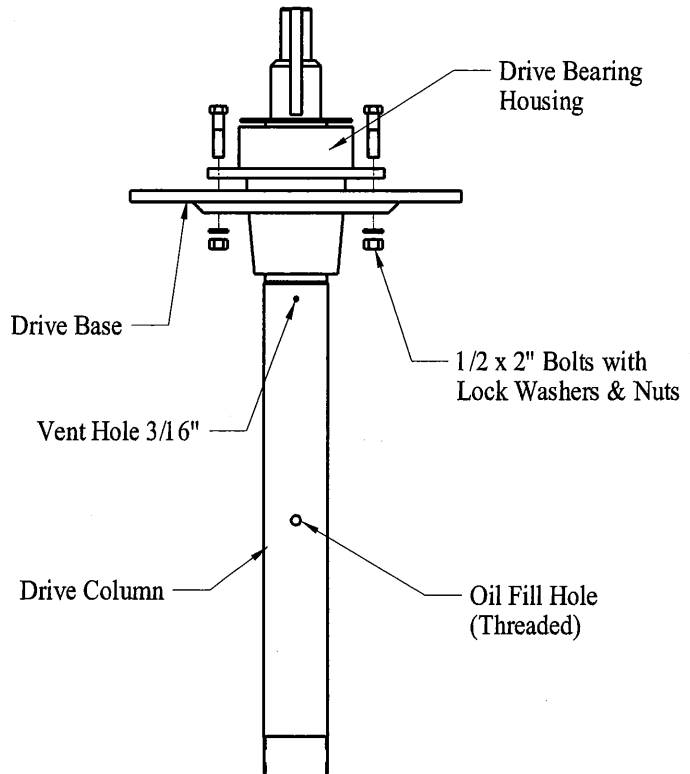

FIGURE 6.

16. Slide the drive column and bearing assembly with drive base onto the drive shaft and thread the column into the column coupling. Tighten both threaded connections.
17. Check again to be sure the impeller is centered in the bowl assembly. Adjust if necessary.
18. Rotate the drive shaft until the keyway in the shaft aligns with the keyway in the bearing assembly and insert the 1/2" x 7/8" (#14,15, and 16 units) drive key furnished.
19. Slide the set collar (M-S Pump), or thread the adjusting nut (Chopper Pump) on the drive shaft. Tighten one setscrew into the 1/2" key securely. The pump assembly will now look like the illustration in Figure 7. The number of intermediate columns and shafts will vary with setting length.

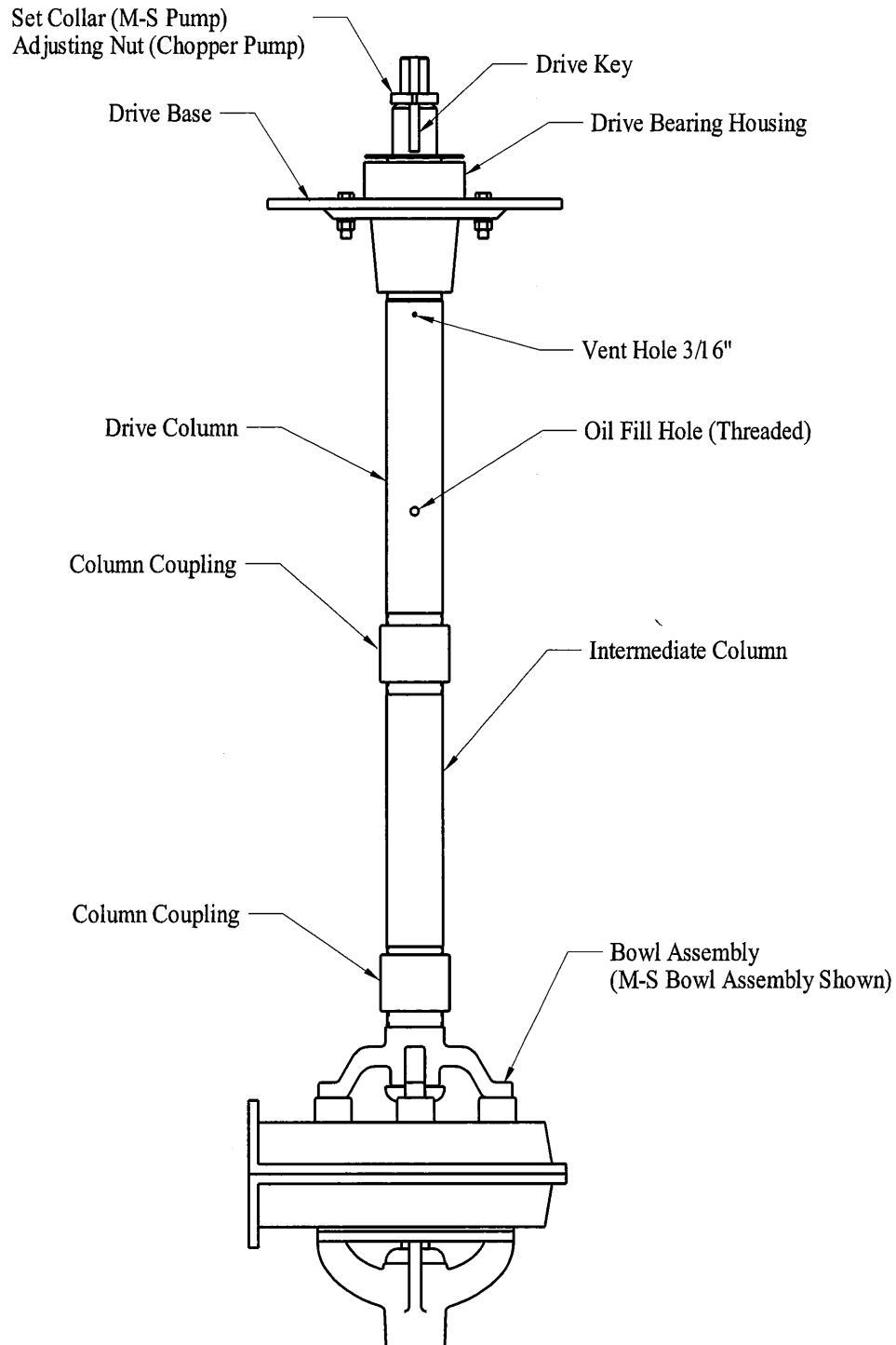

FIGURE 7.



20. Locate the discharge assembly or agitator assembly and the spreader brackets furnished. The table below shows the number of spreader brackets to be used in various settings.

SPREADER BRACKET REQUIREMENTS	
PUMP SETTING LENGTH	SPREADER BRACKETS RECOMMENDED
4 Ft.	0
6 Ft.	0
8 Ft.	1
10 Ft.	2
12 Ft.	2
14 Ft.	2
16 Ft.	3
18 Ft.	3
20 Ft.	4

21. Rotate pump assembly until the discharge flange of pump is vertical to the floor as shown in Figure 8. Assemble the discharge assembly to the pump discharge flange using the discharge clamps provided. Make sure the discharge gasket is in place. Next, attach the spreader brackets at equal distance (not more than four feet apart) from the drive bearing assembly near couplings. See Figure 9.

**NOTE: Take care to have the column sections in alignment before the spreader brackets are tightened. Bearing life can be reduced if the column is not straight.**

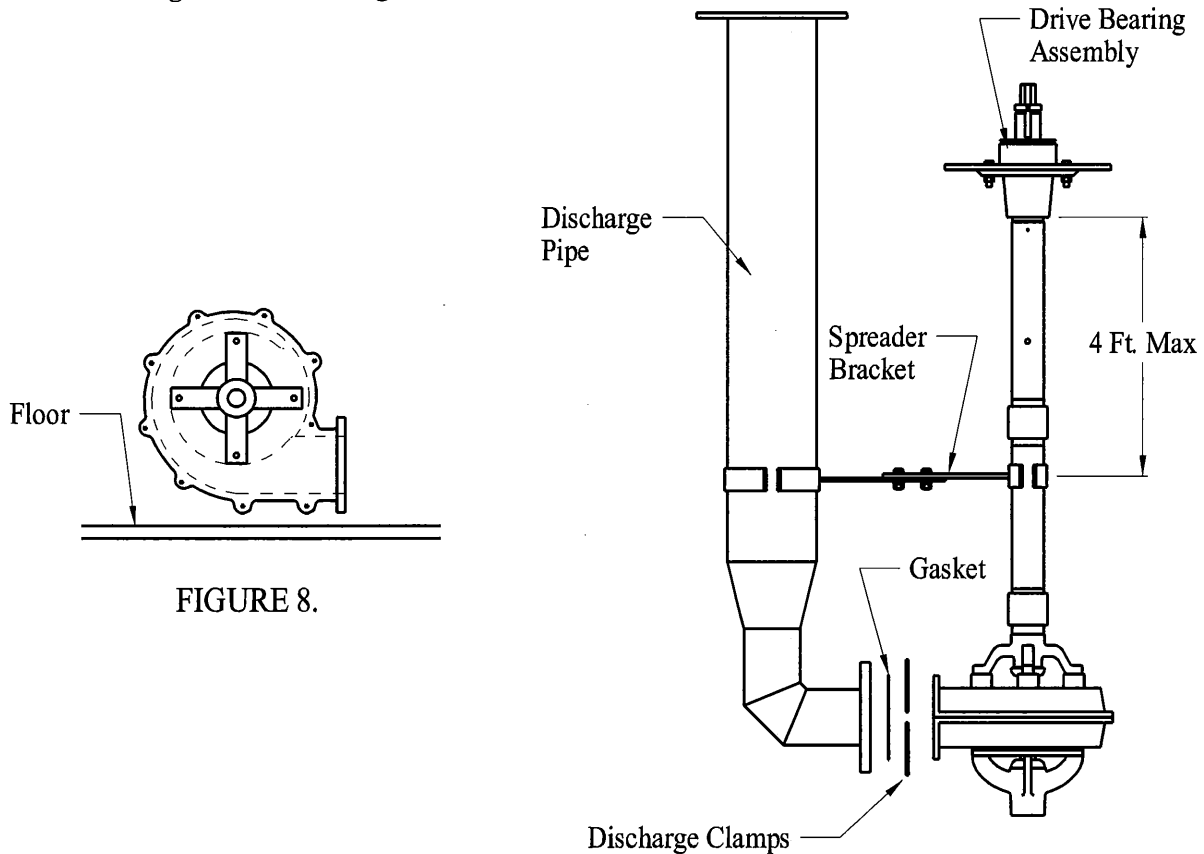

FIGURE 8.

FIGURE 9.

**FINAL ASSEMBLY:**

1. With the pump and discharge pipe lying on the floor, slide the mounting frame for the pump under the drive base. The four slotted tabs on the mounting frame must be on top of the mounting frame and under the drive base. See Figure 10.
2. Fasten the U-bolts around the discharge pipe and through the holes in the mounting frame.
3. Bolt the vertical motor bases to the electric motor, and attach the bases to the mounting frame.

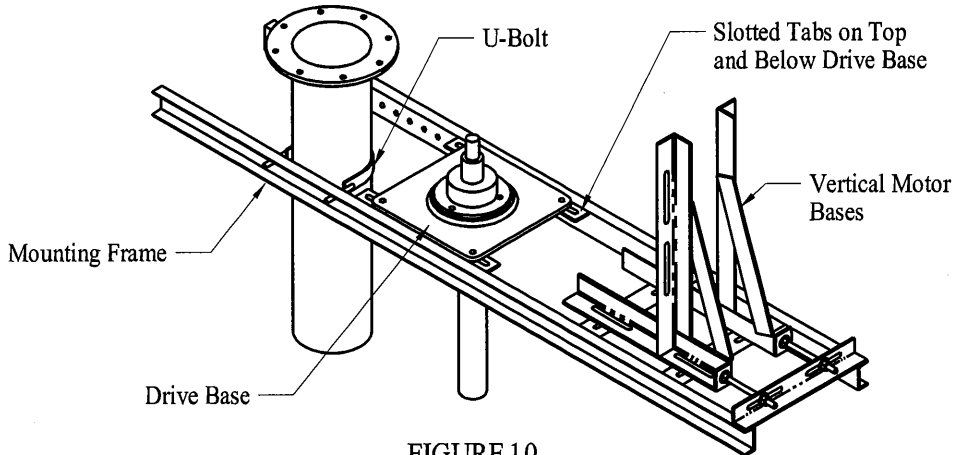

FIGURE 10.

4. Install the sheaves and bushings on the motor and the pump top bearing assembly. Always install the smaller of the two sheaves on the motor to prevent motor failure. Take care to align the sheaves to keep the belts from over heating and to maximize belt life.
5. Install the V-belts and adjust the belt tension with the ½” threaded rod, nuts, and washers provided. Refer to the “Belt Tensioning” paragraph and the “Recommended Deflection Force” table in the Maintenance/Service section of this manual for proper tensioning of the belts.
6. Install the oil reservoir on the drive base using the mounting bracket provided.
7. Thread the sight valve into the bottom of the reservoir, and thread the tubing adaptor into the threaded hole in the drive column. Slide tube nuts and compression fitting onto the oiler tubing and secure the tube to the sight valve and tubing adaptor. See Figure 11.
8. The pump is now ready to be installed on the foundation.

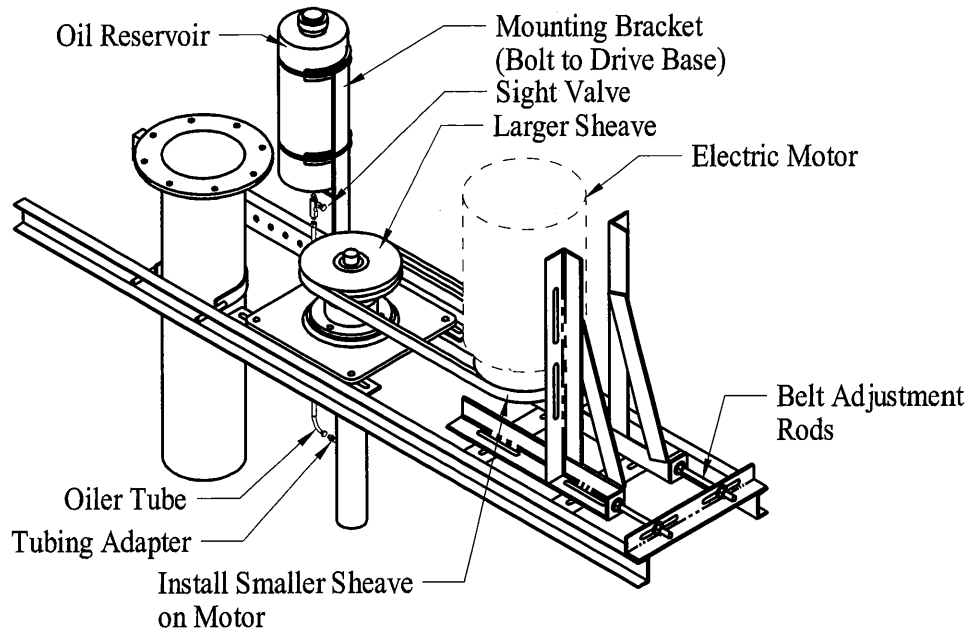

FIGURE 11.

## PUMP INSTALLATION:

1. Lower the pump onto the foundation in the vertical position to prevent damage to columns and shafts.
2. Check the column with a level to assure the pump is square in the vertical position. The mounting frame may require adjusting by shimming.
3. Fill the oil reservoir with SAE 30 oil and allow one tank full of oil to drip into the column before the pump is initially started to assure proper lubrication of the column bearings during start up conditions.
4. Wire the motor (obtaining an electrician if necessary). Start the motor briefly and check the rotation of the pump shaft. **The correct rotation is clockwise looking down on the shaft.** If the shaft turns counter clockwise check the motor plate instructions to change the rotation of the motor. **The pump shaft will unscrew from the couplings if operated counter clockwise.**  
NOTE: Some #18 M-S pumps rotate counter clockwise. Those pumps will be marked accordingly.
5. Install the belt guard to prevent accidental injury.
6. Bolt the discharge pipe to the pump discharge along with a gasket provided.
7. Recheck the pump column alignment with a level to assure the pump is square in the vertical position. Check the pump shaft making sure it turns freely. Alignment is critical on a column pump. Make sure there is no binding or premature bearing wear and shaft breakage will occur.
8. Refer to the lubrication information below for proper oil fill of the pump column. The sight gauge should be closed when the pump is not in operation.
9. The pump is now ready to operate. Use an amp-probe to check the amperage load on the motor. Excessive amperage indicates too small of a motor or sheave ratio should be changed.

## MAINTENANCE/SERVICE INFORMATION

### Lubrication:

- **Column Bearings:** The Parma Pump is furnished with an oiler assembly to provide continuous lubrication to the column bearings. The oil tank holds approximately 2.4 gallons of oil. Before pump operation is started, fill the oil tank and open the valve and allow enough oil to fill the column until oil comes out of the vent hole in the drive column. Then, after operation has started, set the valve to allow five to six drips per minute to flow. If, after continued operation, excess oil continues to come out of the vent adjust the drip accordingly. Check the oil tank often and keep filled.
- **Top Shaft Bearings:** Inspect bearings for wear and heat every 100 hours. **Re-lubrication, when administered correctly, can increase the life of a bearing substantially.** Bearing manufacturers recommend that these bearings be greased daily to weekly, **considering the environmental condition that these pumps are exposed to.** NOTE: Over lubrication is a major cause of bearing failures. Please re-lubricate conservatively. **When selecting a bearing lubricant, use any lithium-based NLGI #2 grease**
- **Bottom Tail Bearing:** Parma Company has available an optional Grease Line Kit that can be installed to grease the bottom tail bearing in the pump along with the top shaft bearing. The life of this bronze sleeve bearing can be increased if this option is installed.

### Shear Hub Adjustment: (Chopper Pumps)

- Check shear hub to shear blade clearance every fifty operating hours under normal operating conditions. More frequent adjustment will be required when the chopper is handling large amounts of straw and bedding.
- The proper clearance between the shear hub and shear blades is .002”-.004”.
- Each full turn of the adjusting nut at the drive bearing assembly will provide .004” adjustment.
- To adjust clearance, disconnect the power to the electric motor, remove the setscrew in the adjusting nut, turn the nut clockwise in half turn increments while turning the pump by hand. When the shear blades contact the shear hub, back off the adjusting nut one full turn, or place the nearest set screw hole over the shaft keyway. This will allow .002”-.004” clearance.
- Replace the setscrew in the adjusting nut, taking care to assure the set screw is seated in the shaft keyway. Do not tighten the setscrew into the shaft threads, since thread damage will occur.
- Replace the belt guard if it was removed.
- Remove any foreign objects from within the belt guard area.

**Belt Tensioning:**

Check belt tensions often. The chart below shows the correct deflection and minimum/maximum force range of various belts used on Parma Pumps. Apply forces evenly across all belts. The forces apply to single belts. For multiple belt tensions multiply the forces by the number of belts used. Do not exceed the maximum force when tensioning belts.

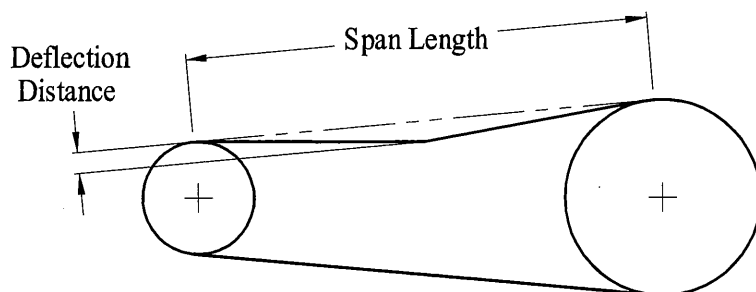

RECOMMENDED DEFLECTION FORCE (lbs.)																		
Span Length																		
Deflection Distance																		
Small Sheave	5/16"		3/8"		7/16"		1/2"		9/16"		5/8"		11/16"		3/4"		13/16"	
	Min.	Max.	Min.	Max.	Min.	Max.	Min.	Max.	Min.	Max.	Min.	Max.	Min.	Max.	Min.	Max.	Min.	Max.
4.60	5.1	7.4	5.1	7.4	5.1	7.4	5.1	7.4	5.1	7.4	5.1	7.4	5.1	7.4	5.1	7.4	5.1	7.4
5.00-5.20	5.8	8.5	5.8	8.5	5.8	8.5	5.8	8.5	5.8	8.5	5.8	8.5	5.8	8.5	5.8	8.5	5.8	8.5
5.40-5.60	6.2	9.1	6.2	9.1	6.2	9.1	6.2	9.1	6.2	9.1	6.2	9.1	6.2	9.1	6.2	9.1	6.2	9.1
6.00-6.80	7.1	10.0	7.1	10.0	7.1	10.0	7.1	10.0	7.1	10.0	7.1	10.0	7.1	10.0	7.1	10.0	7.1	10.0
7.40-9.40	8.1	12.0	8.1	12.0	8.1	12.0	8.1	12.0	8.1	12.0	8.1	12.0	8.1	12.0	8.1	12.0	8.1	12.0

**IMPORTANT!**

The drive belts must be re-tensioned AFTER THE FIRST HALF HOUR OF OPERATION.

# TROUBLESHOOTING

## PROBLEM

1. Motor fails to start.

## CAUSE

- a. Check for blown fuses and tripped thermal overload relay
- b. Incorrect wiring or voltage hookup
- c. Switches not "set" for operation
- d. Starter contacts corroded
- e. Terminal connections broken
- f. Float switch or electrode malfunction

2. Motor starts, but pump fails to turn.

- a. Belt tension not sufficient
- b. Not enough belts to transmit required horsepower
- c. Rubbing or clogged impeller

3. Pump operates, but insufficient or no water delivered.

- a. Wrong pump speed
- b. Re-check head conditions
- c. Discharge pressure may be higher than anticipated
- d. Water level too low
- e. Impeller clogged or damaged
- f. Wrong pump rotation
- g. Suction or discharge lines clogged, or line valves not open
- h. Liquid being pumped may be too viscous. Check percentage of solids. Solids should not exceed 15%.

4. Pump vibrates or is noisy.

- a. Insecure or insufficient foundation
- b. Partially clogged impeller, or the impeller is not balanced
- c. Bent shaft
- d. Worn bearings
- e. Rotating element binding
- f. Suction or discharge pipes not anchored sufficiently
- g. Pump cavitating (Bowl may not be below fluid level)
- h. Drive belt vibration (Motor or pump not secure)

5. Motor overheats or demands excessive amperage

- a. Pump RPM too great for available horsepower. Reduce pump RPM. (Sheave ratio)
- b. Pump plugged with straw or bedding.
- c. Line voltage low. Consult your local power company or electrician.

5. Continued

- d. Bent shaft
- e. Worn bearings
- f. Rotating element binding

6. Continued Shaft  
Breakage

- a. Drive Shaft is not aligned along the assembly.
- b. Improper Shafting Material

# ***PARMA***<sup>®</sup>

---

## **M-S & Chopper Pump PARTS SECTION**

Manual Number 06012012-PMP





## TABLE OF CONTENTS

AGITATOR ASSEMBLY .....	17
CHOPPER PUMP UNIT.....	8
COLUMN & SHAFT ASSEMBLIES .....	12
DISCHARGE ELBOWS.....	19
GEAR BOX .....	14
GREASE LINE KIT.....	18
HYDRAULIC CHOPPER UNIT.....	10
MOUNTING FRAME/DRIVE UNITS .....	15
M-S PUMP UNIT (MODEL 11, 12, & 13).....	2
M-S PUMP UNIT (MODEL 14, 15, 16, & 16LS).....	4
M-S PUMP UNIT (MODEL 18).....	6
PTO DRIVELINE ASSEMBLY.....	16

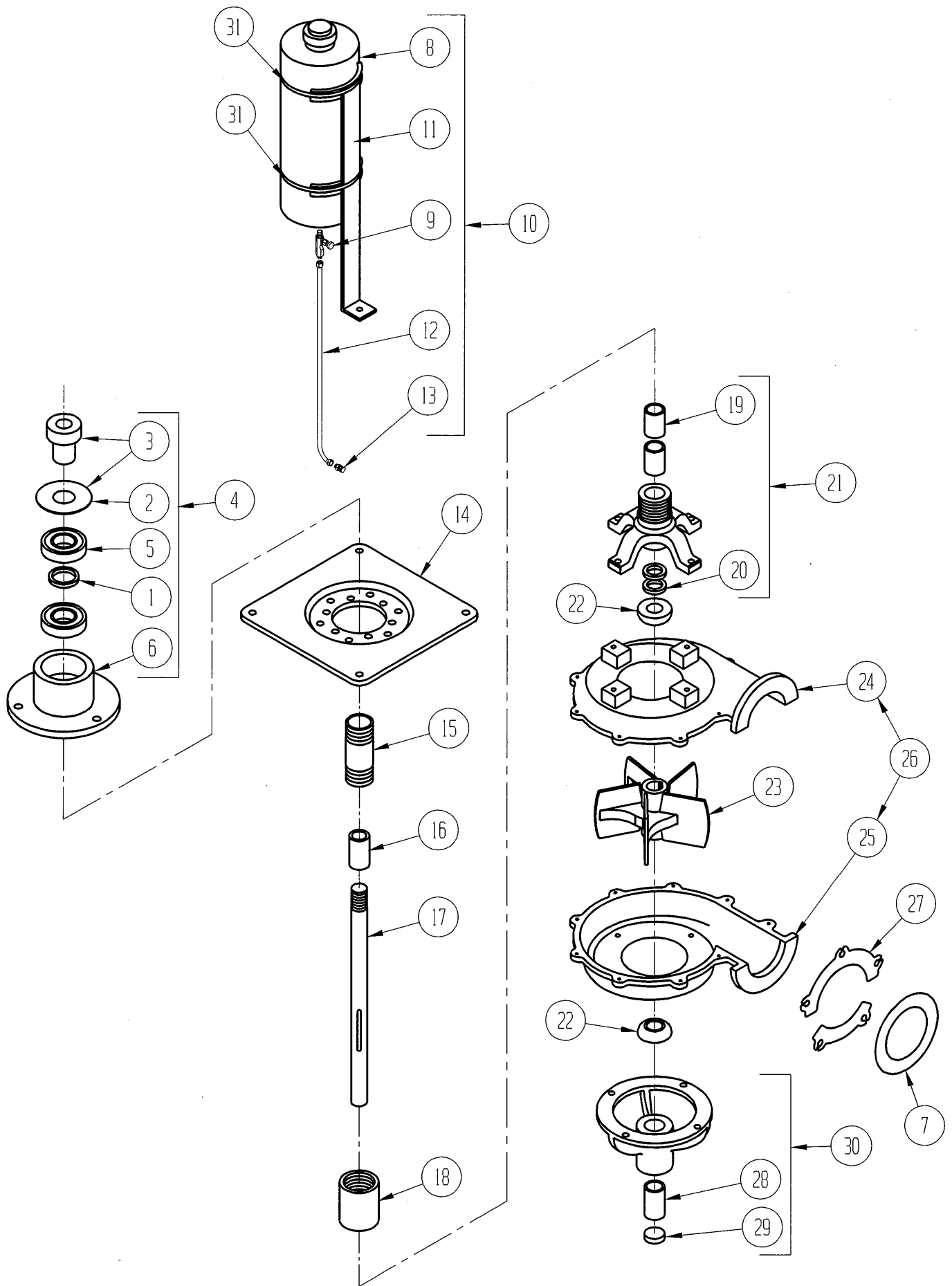

**M-S PUMP UNIT**  
Models 11, 12, & 13

<b>ITEM NO.</b>	<b>QTY</b>	<b>MODEL 11</b>	<b>MODEL 12</b>	<b>MODEL 13</b>	<b>DESCRIPTION</b>
1	1	890021	890021	890021	Spacer
2	1	801049	801049	801049	Dust Cover
3	1	802051	802051	802051	Bearing Quill
4	1	802050	802050	802050	Drive Bearing Assembly
5	1	890030	890030	890030	Bearing
6	1	802052	802052	802052	Drive Bearing Housing
7	1	801355	802355	802355	Gasket
8	1	890312	890312	890312	Oil Tank
9	1	890302	890302	890302	Sight Valve
10	1	801400	801400	801400	Oiler Assembly
11	1	890318	890318	890318	Mounting Bracket
12	1	801401	801401	801401	Tubing
13	1	890303	890303	890303	Tubing Connector
14	1	801070	801070	801070	Drive Base
15	1	801090	-	-	Column Adapter
16	1	890250	890250	890250	Shaft Coupling
17	1	801252	801252	801252	Bowl Shaft
18	1	890201	890201	890201	Column Coupling
19	1	890024	890024	890024	Sleeve Bearing
20	2	890028	890028	890028	Seal
21	1	801150	801150	801150	Top Bearing Assembly
22	2	801152	801152	801152	Bearing Collar
23	1	801251	802251	803251	Impeller
24	1	811201	812201	813201	Top Bowl Half
25	1	811202	812202	813202	Bottom Bowl Half
26	1	811200	812200	813200	Bowl Set
27	1	801354	801354	801354	Discharge Clamp
28	1	-	890026	890026	Sleeve Bearing
29	1	-	890350	890350	Expansion Plug
30	1	-	802300	802300	Bottom Bearing Assembly

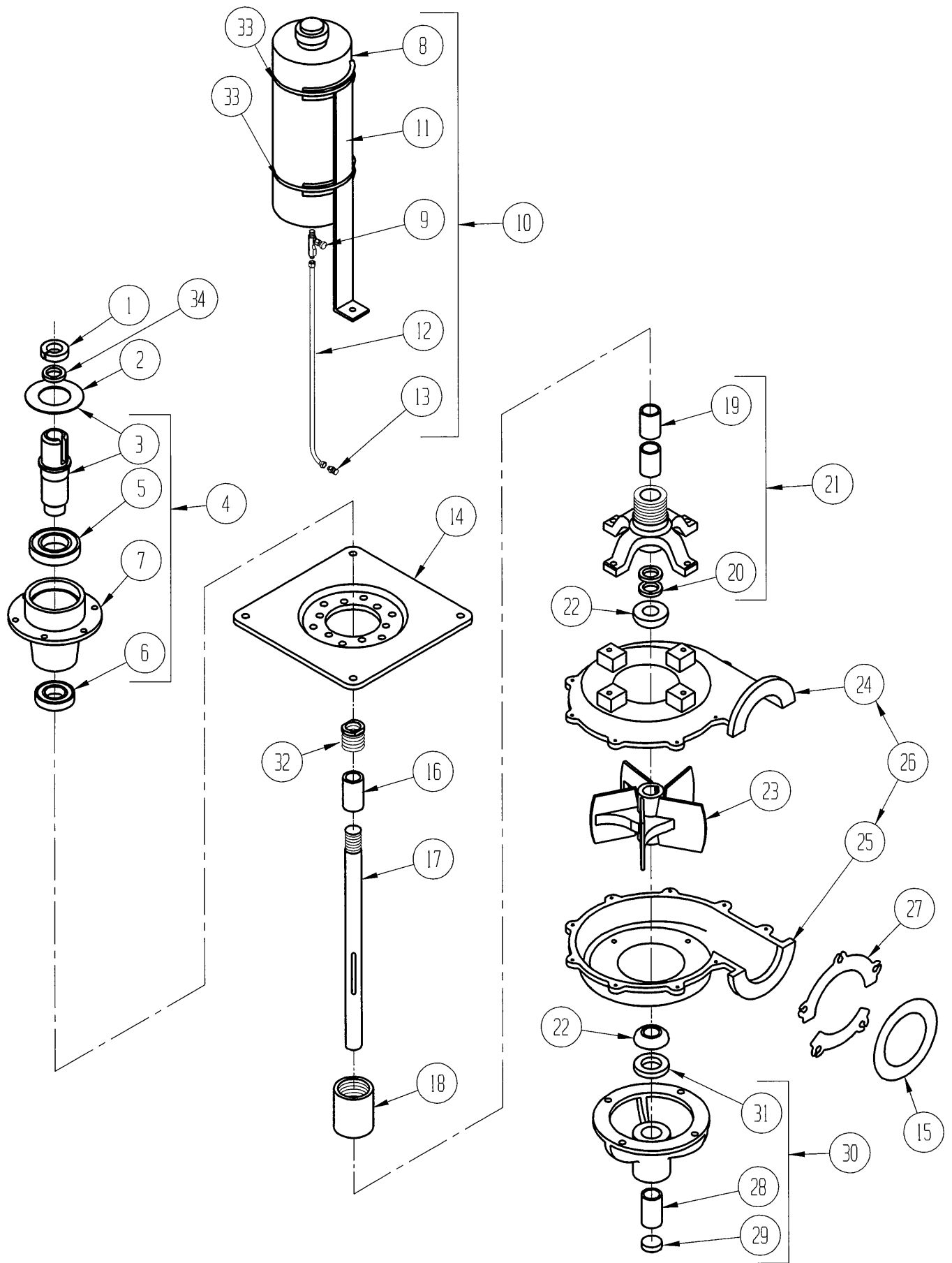

**M-S PUMP UNIT**  
Models 14, 15,16, 16LS

<b>ITEM NO.</b>	<b>QTY</b>	<b>MODEL 14</b>	<b>MODEL 15</b>	<b>MODEL 16</b>	<b>MODEL 16LS</b>	<b>DESCRIPTION</b>
1	1	804054	804054	804054	807055	Set Collar
2	1	804055	804055	804055	804055	Dust Cover
3	1	804056	804056	804056	816024	Bearing Quill Asm
4	1	804050	804050	804050	816020	Drive Bearing Asm
5	1	890031	890031	890031	890031	Bearing
6	1	890032	890032	890032	816023	Bearing
7	1	804052	804052	804052	816021	Drive Bearing Hsng
8	1	890312	890312	890312	890312	Oil Tank
9	1	890302	890302	890302	890302	Sight Valve
10	1	801400	801400	801400	801400	Oiler Assembly
11	1	890318	890318	890318	890318	Mounting Bracket
12	1	801401	801401	801401	801401	Tubing
13	1	890303	890303	890303	890303	Tubing Connector
14	1	801070	801070	801070	801070	Drive Base
15	1	804355	805355	806355	806355	Gasket
16	1	890251	890251	890251	890253	Shaft Coupling
17	1	804252	804252	816252	816220	Bowl Shaft
18	1	890202	890202	890202	890202	Column Coupling
19	X	890046(2)	890046(2)	890023(1)	890023(1)	Sleeve Bearing
20	2	890045	890045	890096	890096	Seal
21	1	834150	834150	816150	816150	Top Bearing Asm
22	2	804152	804152	807152	807152	Bearing Collar
23	1	804251	805251	816260	816260	Impeller
24	1	814201	815201	816201	816201	Top Bowl Half
25	1	814202	815202	816202	816202	Bottom Bowl Half
26	1	814200	815200	816200	816200	Bowl Set
27	1	804354	805354	806354	806354	Discharge Clamp
28	1	890047	890047	890023	890023	Sleeve Bearing
29	1	890352	890352	880007	880007	Expansion Plug
30	1	804300	804300	816310	816310	Bottom Bearing Asm
31	1	-	-	890096	890096	Seal
32	1	-	-	816270	-	Reducer Bushing
33	2	890319	890319	890319	890319	Oil Can Clamp
34	1				814549	Ring Spacer

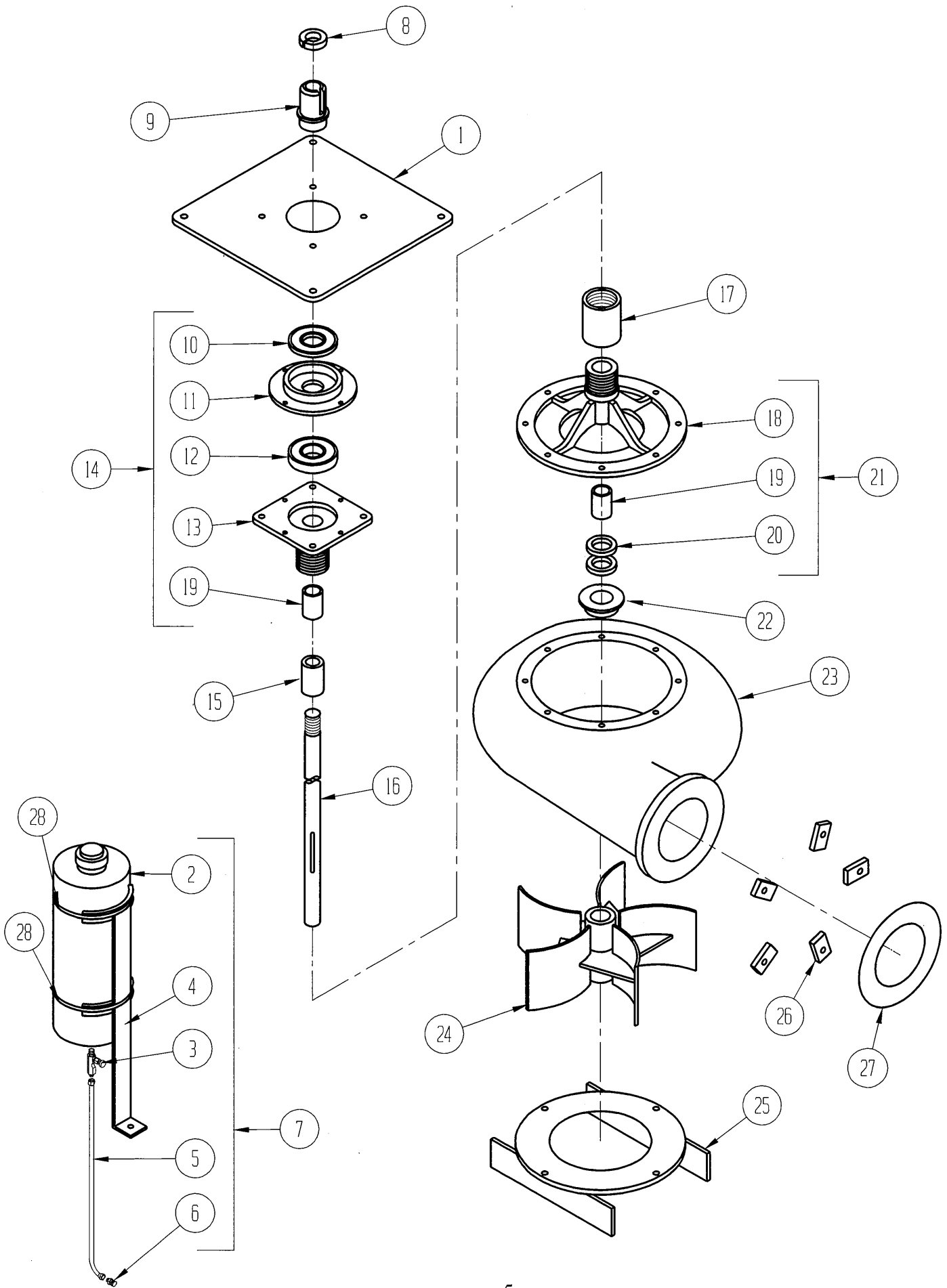

# M-S PUMP UNIT

Model 18

ITEM NO.	QUANTITY	PART NO.	DESCRIPTION
1	1	807075	Drive Base
2	1	890312	Oil Tank
3	1	890302	Sight Valve
4	1	890318	Mounting Bracket
5	1	801401	Tubing
6	1	890303	Tubing Connector
7	1	801400	Oiler Assembly
8	1	807055	Adjusting Nut
9	1	807057	Bearing Quill
10	1	807043	Seal
11	1	807042	Seal Holder
12	1	890035	Bearing
13	1	807058	Drive Bearing Housing
14	1	807041	Drive Bearing Assembly
15	1	890252	Shaft Coupling
16	For One Piece Shaft Numbers See Page 12.		
17	1	890205	Column Coupling
18	1	808155	Top Bearing Housing
19	2	890034	Sleeve Bearing
20	2	890096	Seal
21	1	808154	Top Bearing Assembly
22	1	807152	Bearing Collar
23	1	808201	Pump Bowl (one piece)
24	1	808251	Impeller
25	1	808362	Bowl Flange Pad
26	5	807354	Discharge Clamp
27	1	808355	Gasket

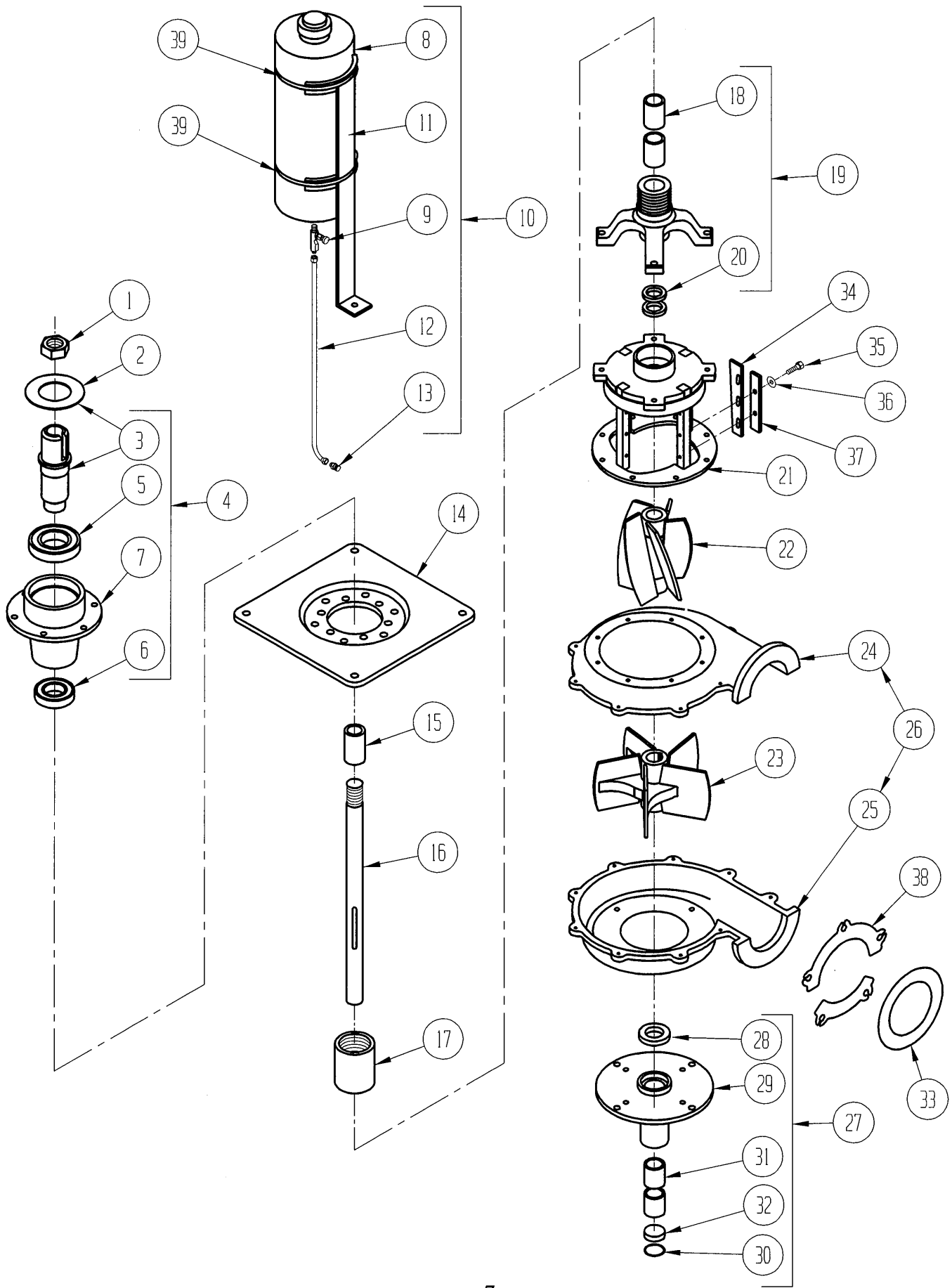



## CHOPPER PUMP UNIT

Models 33, 34, 35, & 36

ITEM NO.	QTY	MODEL 33	MODEL 34	MODEL 35	MODEL 36	DESCRIPTION
1	1	833810	833810	833810	833810	Adjusting Nut
2	1	804055	804055	804055	804055	Dust Cover
3	1	804056	804056	804056	804056	Bearing Quill
4	1	804050	804050	804050	804050	Drive Bearing Assembly
5	1	890031	890031	890031	890031	Bearing
6	1	890032	890032	890032	890032	Bearing
7	1	804052	804052	804052	804052	Drive Bearing Housing
8	1	890312	890312	890312	890312	Oil Tank
9	1	890302	890302	890302	890302	Sight Valve
10	1	801400	801400	801400	801400	Oiler Assembly
11	1	890318	890318	890318	890318	Mounting Bracket
12	1	801401	801401	801401	801401	Tubing
13	1	890303	890303	890303	890303	Tubing Connector
14	1	801070	801070	801070	801070	Drive Base
15	1	890251	890251	890251	890251	Shaft Coupling
16	1	833252*	833252*	833252*	836253	Bowl Shaft
17	1	890202	890202	890202	890202	Column Coupling
18	2 (1)	890046	890046	890046	(890023)	Sleeve Bearing
19	1	834150	834150	834150	816150	Top Bearing Assembly
20	2	890045	890045	890045	890096	Seal
21	1	833801	833801	833801	836254	Shear Housing
22	1	833805	833805	833805	836355	Shear Hub
23	1	833251	834251	835251	836250	Impeller
24	1	823201	824201	825201	826201	Top Bowl Half
25	1	813202	814202	815202	816202	Bottom Bowl Half
26	1	823200	824200	825200	826200	Bowl Set
27	1	833300	834300	834300	816310	Bottom Bearing Asm
28	1	890044	890044	890044	890096	Seal
29	1	833301	834301	834301	816301	Bottom Bearing Housing
30	1	998917	998917	998917	880007	Retaining Ring
31	2 (1)	890046	890046	890046	(890023)	Sleeve Bearing
32	1	890352	890352	890352	-	Expansion Plug
33	1	802355	804355	805355	806355	Gasket
34	4	833806	833806	833806	833806	Shear Blade
35	12	890001	890001	890001	890001	Locking Bolt
36	12	890002	890002	890002	890002	Flat Washer
37	4	833809	833809	833809	833809	Shear Bar
38	1	802354	804354	805354	806354	Discharge Clamp

\*One-piece shaft on certain models – see page 12.

Fill with SAE 30 Oil

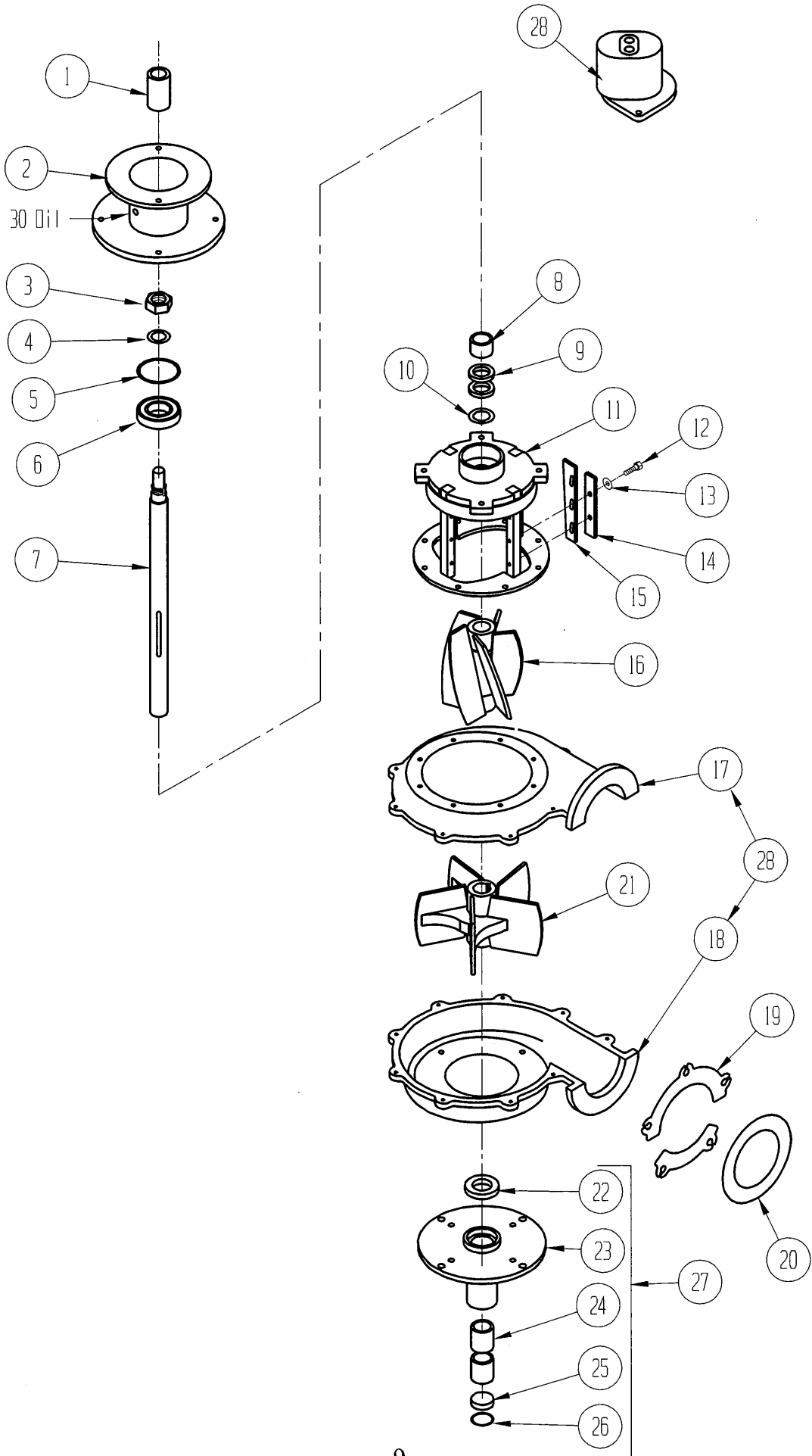

## HYDRAULIC CHOPPER UNIT

Models 34 & 35

ITEM NO.	QUANTITY	MODEL 34	MODEL 35	DESCRIPTION
1	1	100190	100190	Shaft Coupling
2	1	100179	100179	Motor Adapter
3	1	100254	100254	Bearing Locknut
4	1	100235	100235	Bearing Lock Washer
5	1	998914	998914	Retaining Ring
6	1	818058	818058	Bearing
7	1	100178	100178	Bowl Shaft
8	1	818075	818075	Speedi-Sleeve
9	2	890045	890045	Seal
10	1	818060	818060	Wiper Ring
11	1	818051	818051	Shear Housing
12	12	890001	890001	Locking Bolt
13	12	890002	890002	Flat Washer
14	4	833809	833809	Shear Bar
15	4	833806	833806	Shear Blade
16	1	833805	833805	Shear Hub
17	1	824201	825201	Top Bowl Half
18	1	824202	825202	Bottom Bowl Half
19	1	804354	805354	Discharge Clamp
20	1	804355	805355	Gasket
21	1	834251	835251	Impeller
22	1	890044	890044	Seal
23	1	834301	834301	Bottom Bearing Housing
24	1	890046	890046	Sleeve Bearing
25	1	890352	890352	Expansion Plug
26	1	998917	998917	Retaining Ring
27	1	834300	834300	Bottom Bearing Assembly

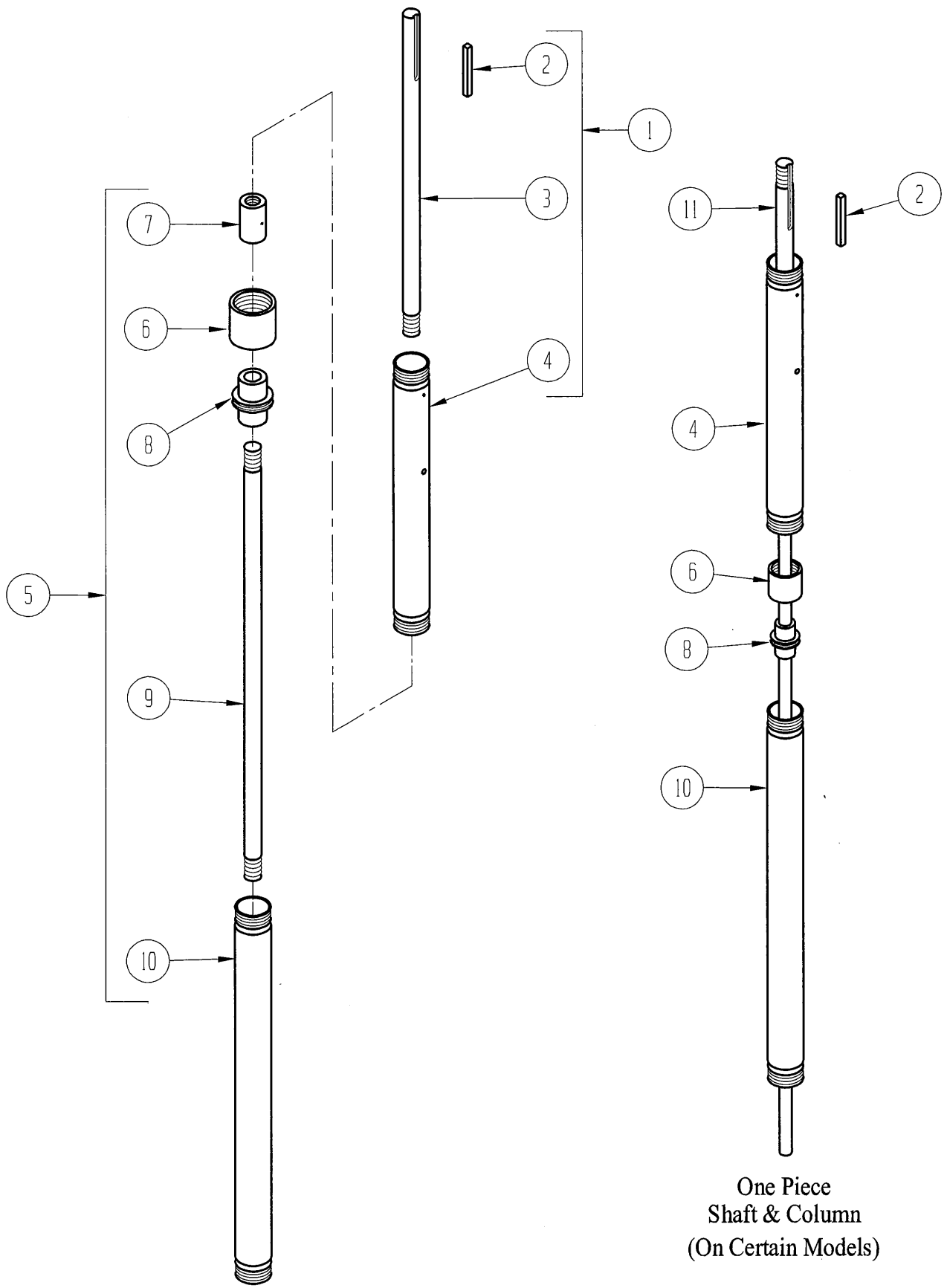

One Piece  
Shaft & Column  
(On Certain Models)

**COLUMN & SHAFT ASSEMBLY**

Multi-Piece Shafts

<b>ITEM NO.</b>	<b>MODEL 11,12,13</b>	<b>MODEL 14,15,16</b>	<b>MODEL 16LS</b>	<b>MODEL 18</b>	<b>MODEL 33,34,35,36</b>	<b>DESCRIPTION</b>
1	801440	804440	816155	807440	823440	Short Drive Column & Shaft Assembly
1	801460	804460	816156	807460	823460	Long Drive Column & Shaft Assembly
2	801053	804053	804053	807401	804043	Key Stock
3	801441	804441	816266	807449	823441	Short Drive Shaft
3	801461	804461	816267	807469	823461	Long Drive Shaft
4	801442	804442	804442	807442	804442	Short Drive Column
4	801462	804462	804462	807463	804462	Long Drive Column
5	801445	804445	816170	807445	804445	Intermediate Column & Shaft Assembly
6	890201	890202	890202	890205	890202	Column Coupling
7	890250	890251	890253	890252	890251	Shaft Coupling
8	890028	890029	890019	890091*	890029	Column Bearing
9	801446	804446	807446	-	804446	Intermediate Shaft – 4'
9	801481	804481	-	-	804481	Intermediate Shaft – 8'
10	801447	804447	804447	807447	804447	Intermediate Column

**COLUMN & SHAFT ASSEMBLY**

One Piece Shafts

<b>ITEM NO.</b>	<b>MODEL 16</b>	<b>MODEL 16LS</b>	<b>MODEL 18</b>	<b>MODEL 34,35</b>	<b>DESCRIPTION</b>
2	801053	816102	807401	804053	Key Stock
4	804442	804442	807442	804442	Short Drive Column
4	804462	804462	807463	804462	Long Drive Column
6	890202	890202	890205	890202	Column Coupling
8	890029	890019	808091*	890029	Column Bearing
10	804447	804447	807447	804447	Intermediate Column
11	100377	816215	100373	107702	Pump Shaft – 6' One Piece
11	100378	816216	100374	834308	Pump Shaft – 8' One Piece
11	100379	816217	100375	834310	Pump Shaft – 10' One Piece
11	100380	816218	100376	100387	Pump Shaft – 12' One Piece

\*Consists of 808090 Housing and 890034 Sleeve Bearing

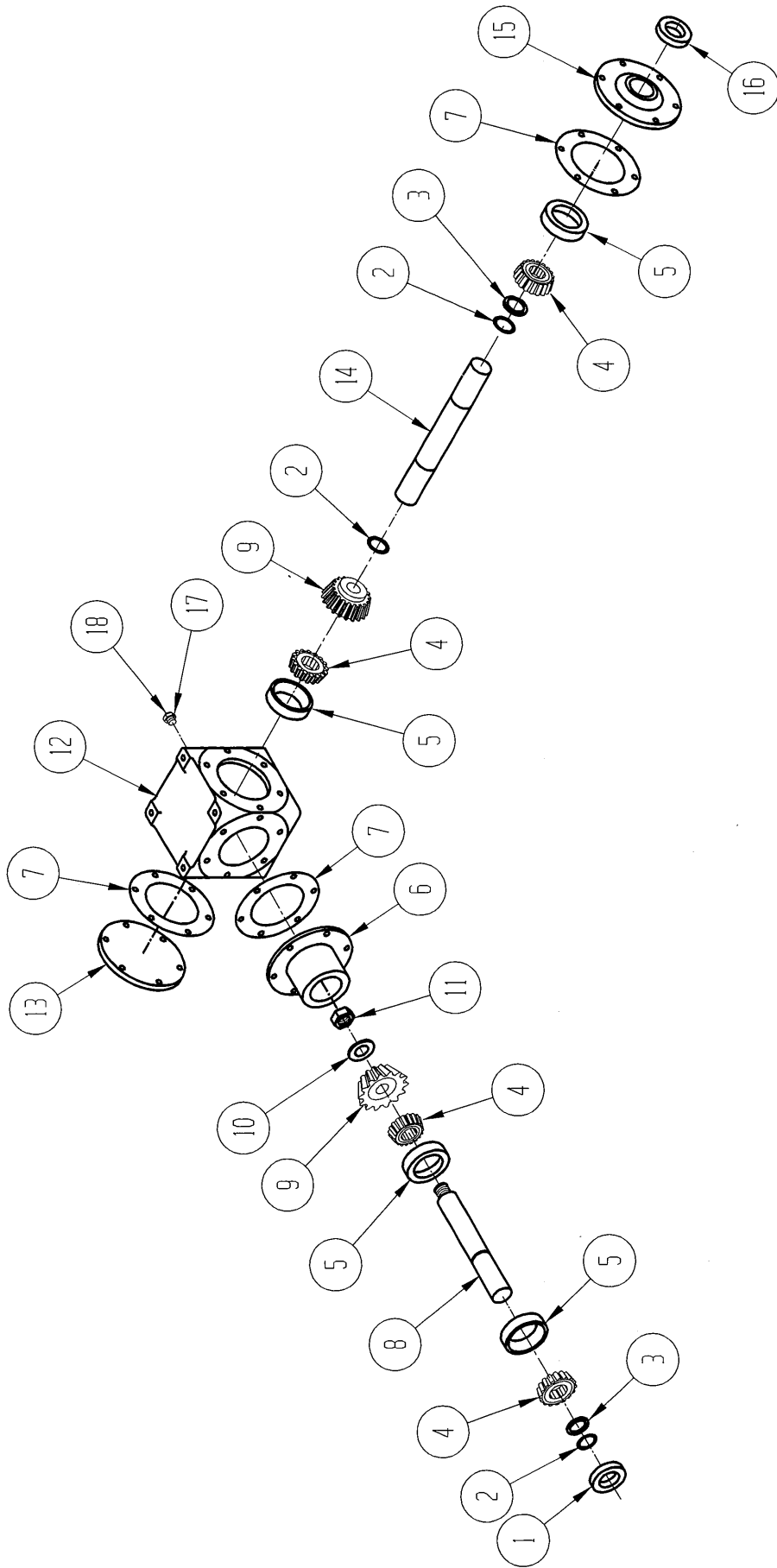

**GEAR BOX**

804643

<b>ITEM NO.</b>	<b>QUANTITY</b>	<b>PART NO.</b>	<b>DESCRIPTION</b>
1	1	999125	Seal
2	3	999127	Retaining Ring
3	2	999126	Spacer Washer
4	4	990004	Bearing Cone
5	4	990005	Bearing Cup
6	1	804654	Pinion Housing
7	As Req'd	804660	Gasket
8	1	804662	Pinion Shaft
9	2	804646	Gear
10	1	804655	Pinion Washer
11	1	999128	Pinion Nut
12	1	804649	Gearbox Case
13	1	804659	Closed End Cap
14	1	804665	Output Shaft
15	1	804653	Open End Cap
16	1	999124	Seal
17	1	-	1/2 x 1/8 Bushing
18	1	999117	Pressure Relief Valve

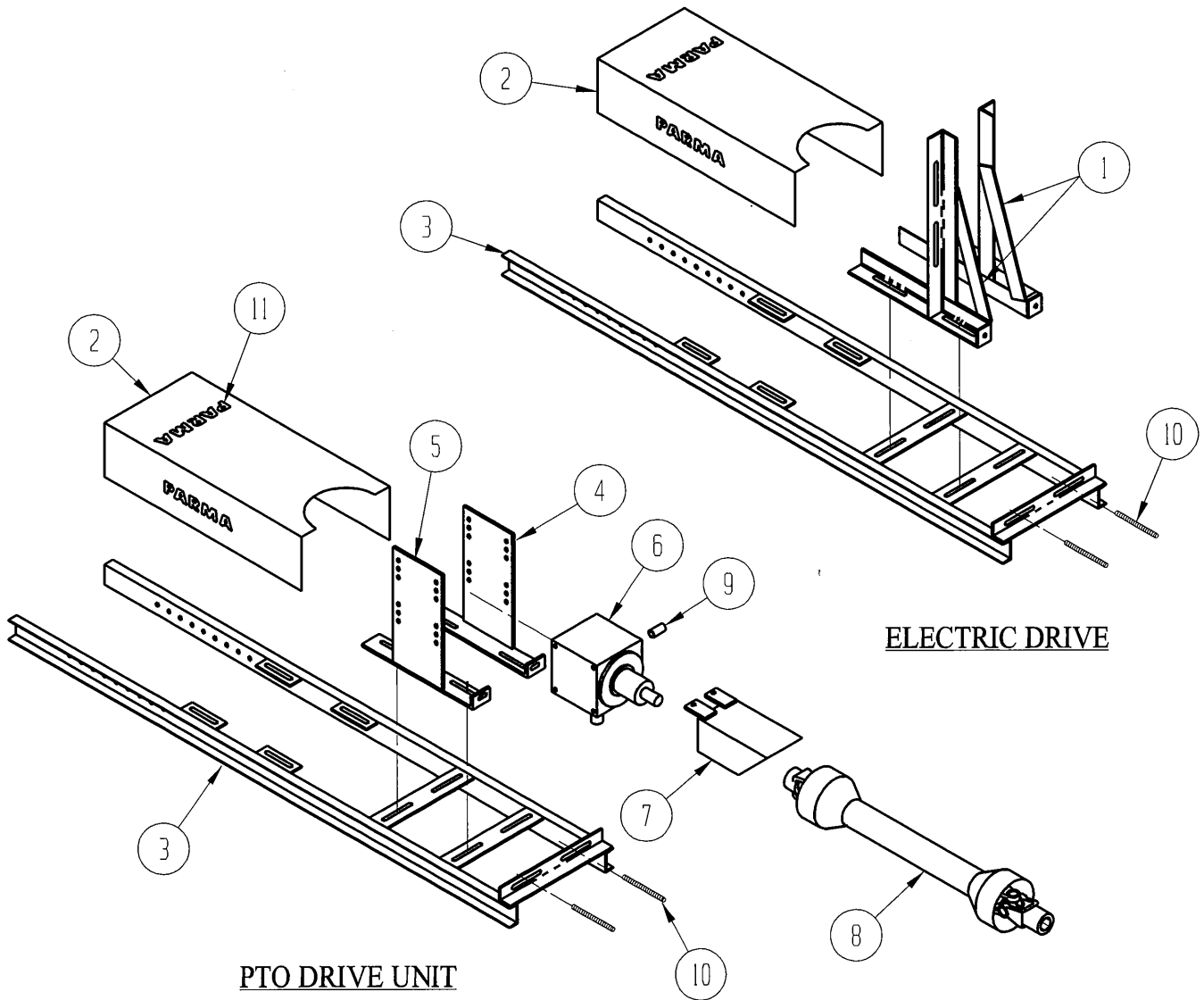

**MOUNTING FRAME/DRIVE UNITS**

ITEM NO.	QTY	1 - 7 1/2 HP	10 - 15 HP	30 - 60 HP	DESCRIPTION
1	1	801700	804700	807700	Vertical Motor Base Assembly
2	1	801860	801860	807740	Belt Guard Assembly
3	1	801600	804600	807600	Mounting Frame
10	2	11"	11"	11"	1/2" Threaded Rod
		<b>540 RPM</b>	<b>1000 RPM</b>		
2	1	801860	801860		Belt Guard Assembly
3	1	804600	804600		Mounting Frame
4	1	804030	804030		Gearbox Adapter, LH
5	1	804031	804031		Gearbox Adapter, RH
6	1	804643	804643		Gear Box
7	1	804036	804036		PTO Guard
8	1	990795	990807		PTO Driveline Assembly
9	4	804032	804032		Spacer
10	2	11"	11"		1/2" Threaded Rod



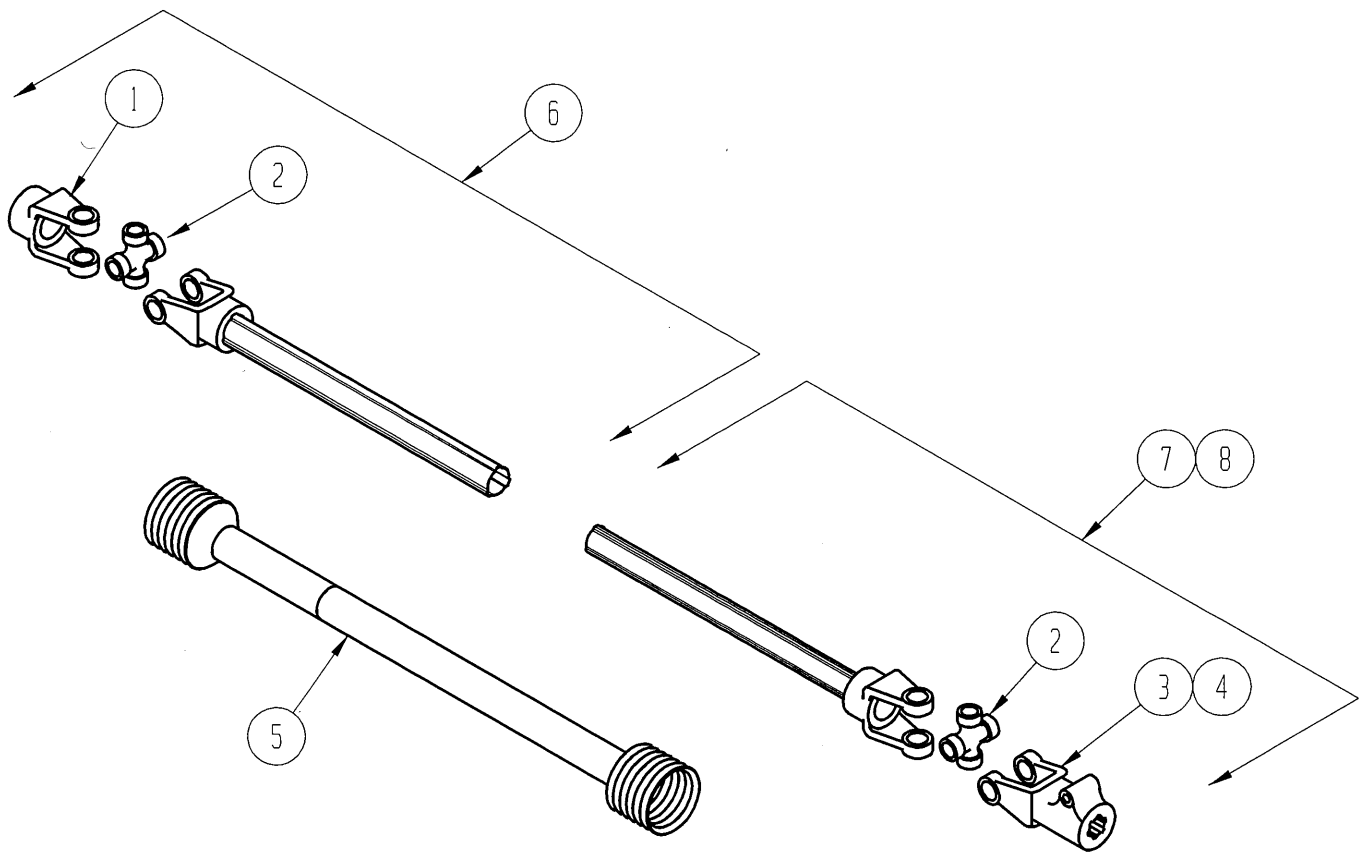

**PTO DRIVELINE ASSEMBLY**  
 990795 (540 RPM) & 990807 (1000 RPM)

ITEM NO.	QUANTITY	PART NO.	DESCRIPTION
1	1	990845	Round Bore Yoke
2	2	990824	Cross & Bearing Kit
3	1	991092	Splined Yoke, 1 3/8-6
4	1	990813	Splined Yoke, 1 3/8-21
5	1	991072	Shield Assembly
6	1	990438	Driveline Implement Half w/ shield
7	1	990448	Driveline Tractor Half w/ shield (540 RPM)
8	1	990434	Driveline Tractor Half w/ shield (1000 RPM)

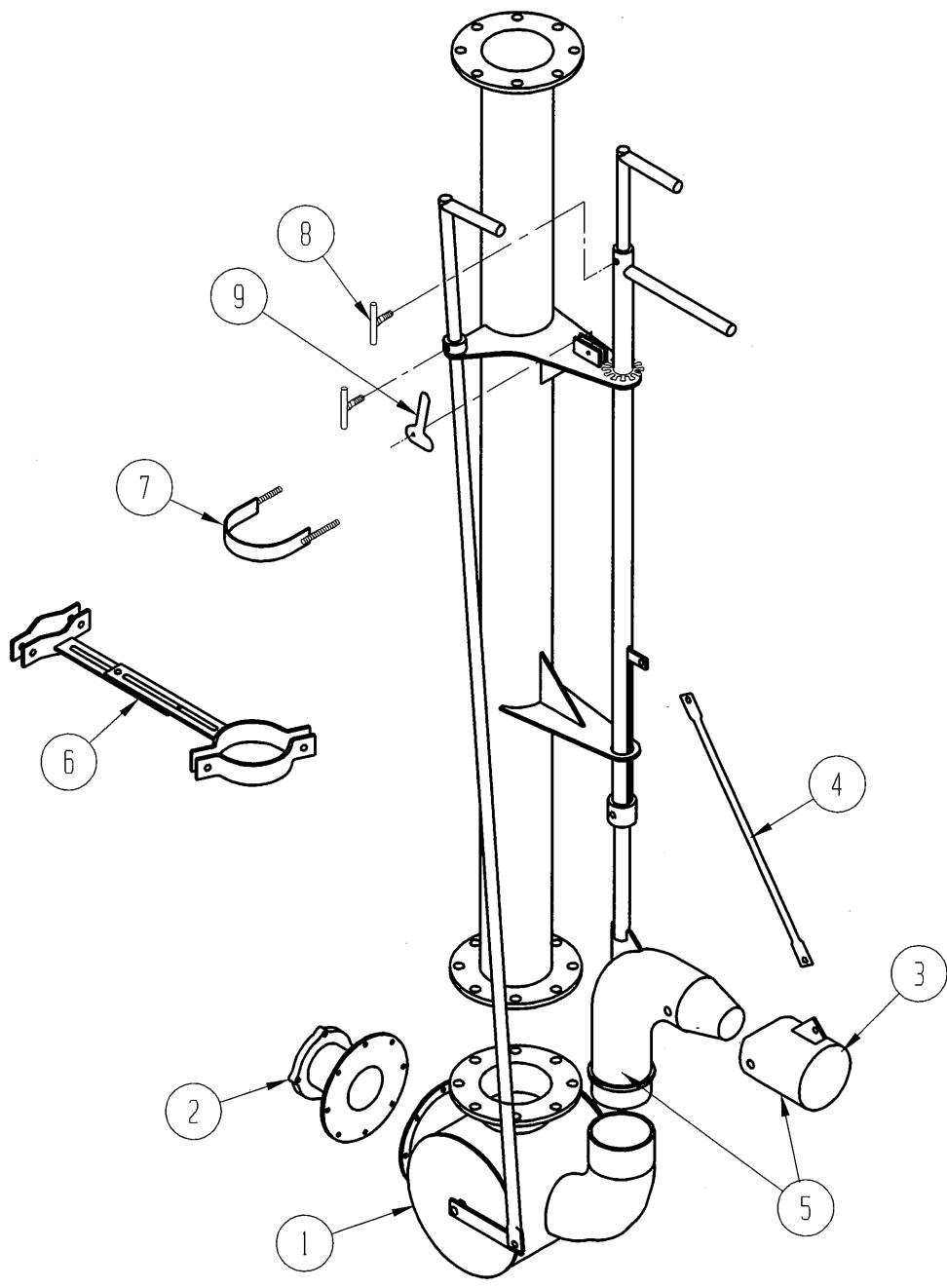

**AGITATOR ASSEMBLY**

ITEM NO.	QUANTITY	PART NO.	DESCRIPTION
1	1	814508	Agitator Box
2	1	814539	Discharge Adapter, 4"
3	1	814458	Swivel Nozzle
4	1	814528	Pipe Brace
5	1	814429	Nozzle Weldment
6	1	814466	Spreader Bracket Assembly, 6 x 2 1/2
7	1	802360	U-Bolt
8	2	815308	Tee Handle
9	1	814496	Positioning Handle

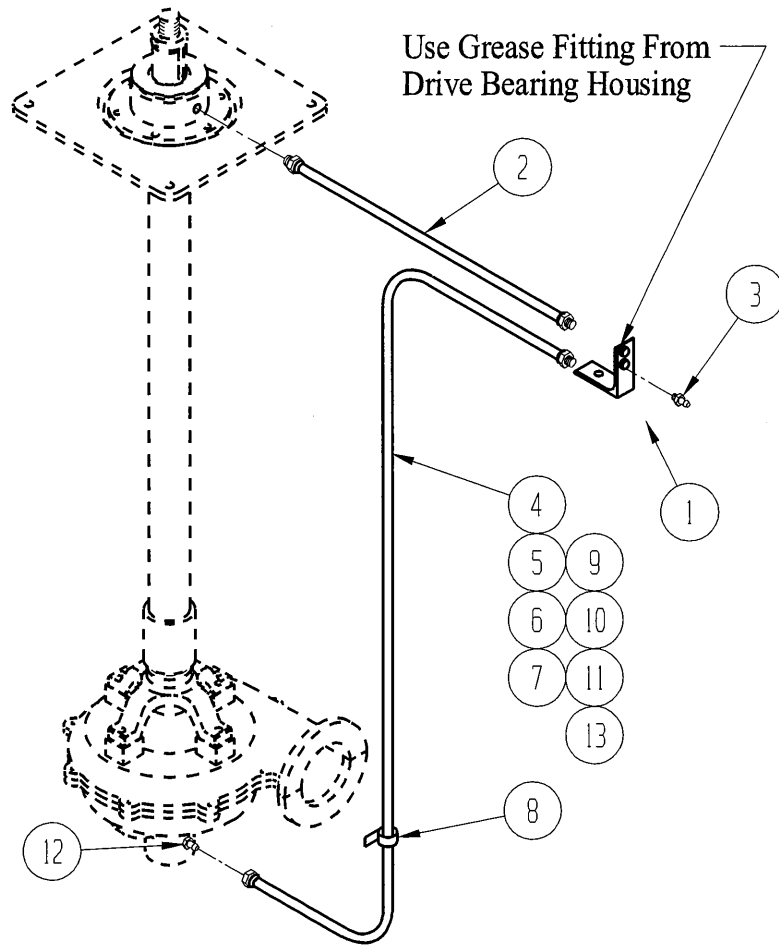

**GREASE LINE KIT**

ITEM NO.	QTY	6' 100717	8' 100718	10' 100719	12' 100720	DESCRIPTION
1	1	100707	100707	100707	100707	Grease Fitting Bracket
2	1	801460	804460	807460	823460	Hydraulic Hose, 1/4 x 24
3	1	100578	100578	100578	100578	Grease Fitting, 1/8 NPT
4	1	100709	-	-	-	Hydraulic Hose, 1/4 x 102
5	1	-	100710	-	-	Hydraulic Hose, 1/4 x 126
6	1	-	-	100711	-	Hydraulic Hose, 1/4 x 150
7	1	-	-	-	100712	Hydraulic Hose, 1/4 x 174
8	2	100708	100708	100708	100708	Hose Clamp

ITEM NO.	QTY	14' 100717	16' 100718	18' 100719	DESCRIPTION
1	1	100707	100707	100707	Grease Fitting Bracket
2	1	801460	804460	807460	Hydraulic Hose, 1/4 x 24
3	1	100578	100578	100578	Grease Fitting, 1/8 NPT
8	2	100708	100708	100708	Hose Clamp
9	1	100755	-	-	Hydraulic Hose, 1/4 x 198
10	1	-	100756	-	Hydraulic Hose, 1/4 x 222
11	1	-	-	100757	Hydraulic Hose, 1/4 x 246

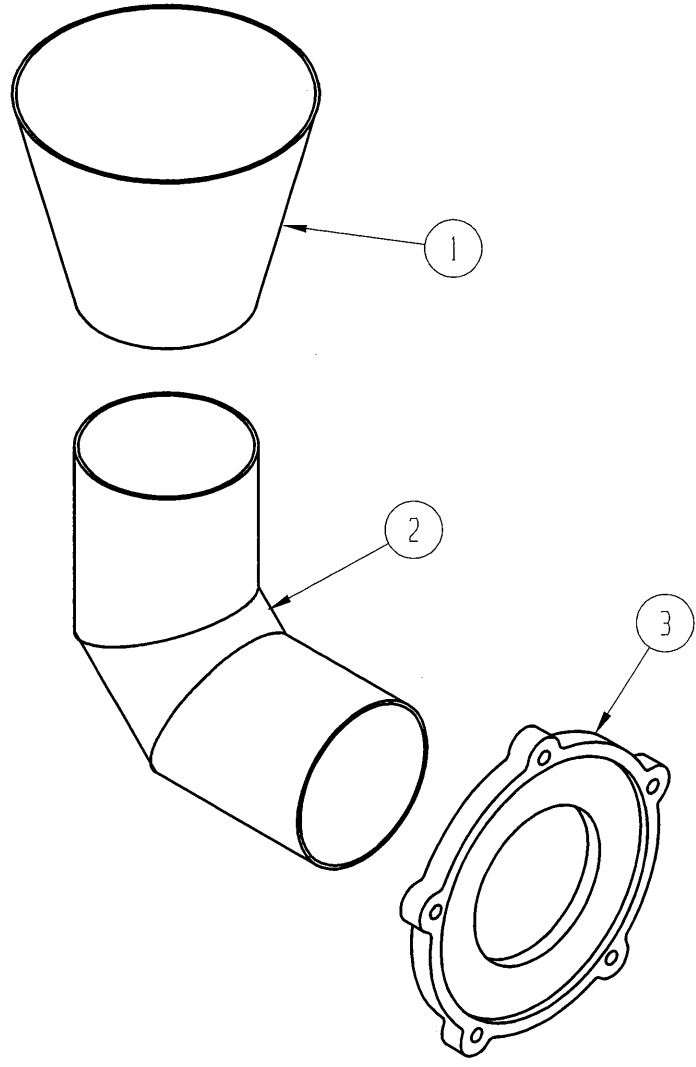

**DISCHARGE ELBOWS**

ITEM NO.	MODEL 11	MODEL 12,13,33	MODEL 14,34	MODEL 15,35	MODEL 16,36	MODEL 18	DESCRIPTION
	801350	802350	804350	805350	806350	808350	Discharge Elbow
1	891334 3" x 4"	891346 4" x 6"	891358 5" x 8"	891361 6" x 10"	891393 8" x 12"	891310 10" x 16"	Welding Cone
2	801351*	802351*	801905 5"	801906 6"	804908 8"	804910 10"	90° Elbow
3	-	-	804351	805351	806351	808351	Nose Flange

\*Elbow and nose flange are cast together as one piece.

## NOTES