

PARMA[®]

LAND PLANE
Rigid and Folding Models
OWNERS MANUAL

Manual Number 010610-LP

PARMA COMPANY

P.O. BOX 190
PARMA, IDAHO 83660
PHONE (208) 722-5116 FAX (208) 722-6012
E-Mail: www.parmacompany.com

INDEX

CUSTOMER AND DEALER CHECKLIST	8
FIELD SETUP	10
FOLDING MODELS.....	12
HIGHWAY TRANSPORT.....	6,10
HITCH ADJUSTMENTS	10
INTRODUCTION	1
LUBRICATION	12
MAINTENANCE AND FIELD ADJUSTMENTS	10
REAR WHEEL ADJUSTMENT.....	11
SAFETY PRECAUTIONS.....	2
S-TINES	11
TRAVERSING DITCHES AND LEVEES	12
WARRANTY POLICY	9
PARTS BOOK SECTION.....	13

INTRODUCTION

This manual has been prepared to acquaint you with the operation and maintenance of your **PARMA Land Plane**, and to provide important safety information. We urge you to read this manual carefully. The recommendations will help assure the safe and trouble free operation of your machine.

When it comes to service, keep in mind that your dealer knows your Land Plane well and is interested in your complete satisfaction. Your dealer invites you to call him for your service needs both during and after the warranty period.

We thank you for choosing a PARMA product and want to assure you of our continuing interest in your satisfaction. You have purchased a very good machine and with proper care it will give you good service.



SAFETY: THE MOST IMPORTANT SUBJECT OF ALL...YOU CAN LIVE WITH IT!

The Following safety instructions are provided to help assure that all operators of this equipment are trained in its operation and are familiar with the importance of safety in its use.



WITH OWNERSHIP COMES RESPONSIBILITY!

Many times the owner of this equipment is not the operator. The manufacturer delivers the equipment to a dealer, who in turn sells it to an owner. The owner may then assign another person to operate it. With each of these steps it is the duty of the one in possession of the equipment to be sure that the safe operation of the machine is fully explained to the person, or persons, actually operating it. **Do not allow this machine to be used until the following safety material has been reviewed.**

REMEMBER: One of the most common causes of injury or death around this type of equipment is because the operator does not shut the tractor engine off and remove the key when maintenance, adjustments, or cleaning of the machine is conducted!



SAFETY... YOU CAN LIVE WITH IT!

SAFETY PRECAUTIONS

TAKE NOTE! THIS SAFETY ALERT SYMBOL FOUND THROUGH OUT THIS MANUAL IS USED TO CALL YOUR ATTENTION TO INSTRUCTIONS INVOLVING YOUR PERSONAL SAFETY AND THE SAFETY OF OTHERS. FAILURE TO FOLLOW THESE INSTRUCTIONS CAN RESULT IN INJURY OR DEATH.



THIS SYMBOL MEANS

-ATTENTION!

-BECOME ALERT!

- YOUR SAFETY IS INVOLVED!

SIGNAL WORDS:

Note the use of the signal words **DANGER**, **WARNING** and **CAUTION** with the safety messages. The appropriate signal word for each has been selected using the following guidelines:

DANGER: Indicates an imminently hazardous situation that, if not avoided, will result in death or serious injury. This signal word is to be limited to the most extreme situations typically for machine components for which functional purposes cannot be guarded.

WARNING: Indicates a potentially hazardous situation that, if not avoided, could result in death or serious injury, and includes hazards that are exposed when guards are removed. It may also be used to alert against unsafe practices.

CAUTION: Indicates a potentially hazardous situation that, if not avoided, may result in minor or moderate injury. It may also be used to alert against unsafe practices, and potential for equipment damage.

If you have questions not answered in this manual or require additional copies or the manual is damaged, please contact your dealer.

SAFETY.... YOU CAN LIVE WITH IT



SAFETY.... YOU CAN LIVE WITH IT



EQUIPMENT SAFETY GUIDELINES

Safety of the operator is one of the main concerns in designing and developing a new piece of equipment. Designers and manufacturers build in as many safety features as possible. However, every year many accidents occur which could have been avoided by a few seconds of thought and a more careful approach to handling equipment. You, the operator, can avoid many accidents by observing the following precautions in this section. To avoid personal injury, study the following precautions and insist those working with you, or for you, follow them.

Replace any CAUTION, WARNING, DANGER or instruction safety decal that is not readable or is missing. Location of such decals is indicated in this manual.

Do not attempt to operate this equipment under the influence of drugs or alcohol.

Review the safety instructions with all users annually.

This equipment is dangerous to children and persons unfamiliar with its operation. The operator should be a responsible adult familiar with farm machinery and trained in this equipment's operations. **Do not allow persons to operate or assemble this unit until they have read this manual and have developed a thorough understanding of the safety precautions and of how it works.**

Do not paint over, remove or deface any safety signs or warning decals on your equipment. Observe all safety signs and practice the instructions on them.

Never exceed the limits of a piece of machinery. If its ability to do a job, or to do so safely is in question – **DON'T TRY IT.**



LIGHTING AND MARKING

It is the responsibility of the customer to know the lighting and marking requirements of the local highway authorities and to install and maintain the equipment to provide compliance with the regulations. Add extra lights when transporting at night or during periods of limited visibility.

Lighting kits are available from your dealer or from the manufacturer.

SAFETY SIGN LOCATIONS

The types of Safety Sign on the equipment are shown below. Their locations are shown in the parts section of this manual. Good safety requires that you familiarize yourself with the various Safety Signs, the type of warning and the area, or particular function related to that area that requires your SAFETY AWARENESS.

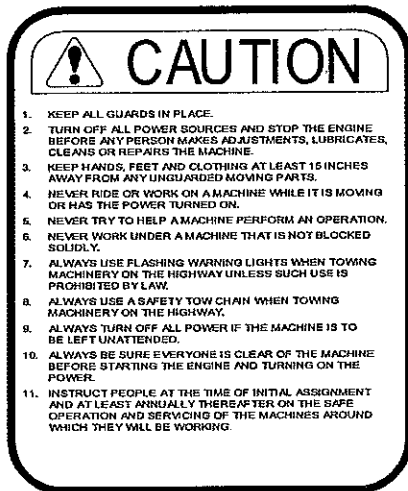

100406

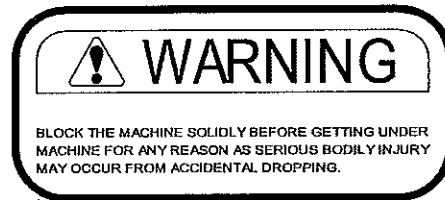

100404

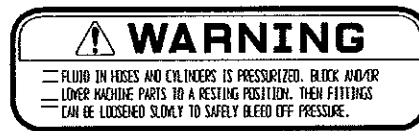

100408

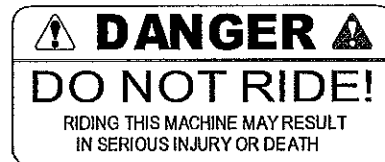

265933

REMEMBER: If Safety Signs have been damaged, removed, become illegible or parts replaced without decals, new decals must be applied. New decals are available from your authorized dealer or manufacturer.



SAFETY SIGN CARE

- Keep safety signs clean and legible at all times
- Replace safety signs that are missing or have become illegible
- Replaced parts that displayed a safety sign should also display the current sign
- Safety signs are available from your Dealer Parts Department or the Manufacturer

How to Install Safety Signs:

- Be sure that the installation area is clean and dry
- Decide on the exact position before you remove the backing paper
- Remove the smallest portion of the split backing paper
- Align the decal over the specified area and carefully press the small portion with the exposed sticky backing in place
- Slowly peel back the remaining paper and carefully smooth the remaining portion of the decal in place
- Small air pockets can be pierced with a pin and smoothed out using the piece of decal backing paper



REMEMBER!

Your best assurance against accidents is a careful and responsible operator. If there is any portion of this manual or function you do not understand, contact your local authorized dealer or the manufacturer.



BEFORE OPERATING:

- Carefully study and understand this manual
- Assure that agricultural implement tires are inflated evenly
- Inspect the unit for any loose bolts, worn parts or cracked welds, and make necessary repairs. Follow the maintenance safety instructions included in this manual
- Be sure that there are no tools lying on or in the equipment
- Do not use the unit until you are sure that the area is clear, especially children and animals
- Don't hurry the learning process or take the unit for granted. Ease into it and become familiar with your new equipment
- Practice operation of your equipment and its attachments. Completely familiarize yourself and other operators with its operation before using



DURING OPERATION:

- **NO PASSENGERS ALLOWED** – Do not allow any passengers to ride on the equipment at any time
- Be especially observant of the operating area and terrain – watch for holes, rocks or other hidden hazards.
- Don't work under raised components or attachments unless securely positioned and blocked
- Keep all bystanders, pets and livestock clear of the work area
- As a precaution, always recheck the hardware on equipment following every 100 hours of operation. Correct all problems. Follow the maintenance safety procedures



FOLLOWING OPERATION:

- Following operation, or when unhitching, stop the tractor, set the brakes, **shut off the engine and remove the ignition key**
- Store the unit in an area away from human activity
- Do not permit children to play on or around the stored unit
- Make sure all parked machines are on a hard, level surface and engage all safety devices



HIGHWAY AND TRANSPORT OPERATIONS:

- Adopt safe driving practices:
 1. Always drive at a safe speed relative to local conditions and ensure that your speed is low enough for an emergency to stop to be safe and secure. Keep speed to a minimum
 2. Reduce speed prior to turns to avoid the risk of overturning
 3. Always keep the tractor in gear to provide engine braking when going downhill. Do not coast
 4. **Do not drink and drive!**
- Comply with state and local laws governing highway safety and movement of farm machinery on public roads
- Use wing locks during transportation.
- Use approved accessory lighting flags and necessary warning devices to protect operators of other vehicles on the highway, during daylight and nighttime transport, in accordance with State Department of Transportation specifications. Various safety lights and devices are available from your Dealer
- The use of flashing amber lights is acceptable in most localities. However, some localities prohibit their use. Local laws should be checked for all highway lighting and marking requirements. Be a safe and courteous driver. Always yield to oncoming traffic in all situations, including narrow bridges, intersections, etc

- Be a safe and courteous driver. Always yield to oncoming traffic in all situations, including narrow bridges, intersections, etc
- Be observant of bridge loading ratings. Do not cross bridges rated lower than the gross weight at which you are operating
- Watch for obstructions overhead and to the side while transporting
- Always operate equipment in a position to provide maximum visibility at all times.
- Traversing ditches with the Parma Land Plane that are over three feet wide and twelve inches deep, or crossing over levees over twelve inches high and at a ninety-degree angle to the ditch or levee **SHOULD BE AVOIDED**. See page 12-Ditches.



PERFORMING MAINTENANCE:

- Good maintenance is your responsibility. Poor maintenance is an invitation to trouble
- Before working on this machine, **shut off the tractor engine and remove the ignition key**
- **Always** use a safety support. Never use a jack to support the machine
- Always use the proper tools or equipment for the job at hand
- Use extreme caution when making adjustments
- Never use your hands to locate a hydraulic leak on attachments. Use a small piece of cardboard or wood. Hydraulic fluid escaping under pressure can penetrate the skin
- When disconnecting hydraulic lines, shut off hydraulic supply and relieve all hydraulic pressure
- Openings in the skin and minor cuts are susceptible to infection from hydraulic fluid. **If injured by escaping hydraulic fluid, see a doctor at once. Gangrene can result. Without immediate medical treatment, serious infection and reactions can occur**
- After servicing, be sure all tools, parts and service equipment are removed
- Never replace hex bolts with less than grade five bolts unless otherwise specified.
- Where replacement parts are necessary for periodic maintenance and servicing, genuine factory replacement parts are recommended to restore your equipment to original specifications. The manufacturer will not claim responsibility for use of unapproved parts and/or accessories and other damages as a result of their use
- If equipment has been altered in any way from original design, the manufacturer does not accept any liability for injury or warranty

CUSTOMER AND DEALER CHECKLIST

After the machine has been completely assembled, inspect it thoroughly to be certain it is in operating condition before delivering it to a customer. The following checklist is a reminder of points to inspect. Check off each item as it is found satisfactory or after proper adjustment is made.

PRE-DELIVERY:

- Check all bolts and nuts to be sure they are tight. **Double check the carrier wheel lug bolts.**
- Inspect and, if necessary, grease at all lubrication points; making sure all bearings are taking grease.
- Check all moving parts for smooth operation.
- Check to see that all hydraulic fittings and cylinders are tight and free of leaks.

DELIVERY:

- Complete the Delivery and Warranty Registration Forms, listing serial numbers of machine.
- Have the dealer and customer sign the form. Explain warranty policy on the Warranty Registration Form. Return the factory copy of the form to Parma Company.
- Show the customer how to operate the Land Plane
- Explain adjustments and the importance of proper lubrication.
- Give the operator's manual to the customer and ask him to familiarize himself with all sections of it.
- Explain to the customer that when the equipment is transported on a road or highway at night or during the day, accessory lights and devices should be used for adequate warning to operators of other vehicles per local regulations.

BEFORE EACH SEASON:

- Check s-tine chisel points for normal wear.
- Check all adjustable components for correct setting.
- Perform complete lubrication of machine.
- Read the safety precautions.
- Read operating instructions.
- Perform daily checklist.

DAILY CHECKLIST:

- Remove all debris from the s-tines.
- Lubricate all lubrication points.
- Check for loose or missing bolts or parts (**especially on S-Tines**).
- Check for undue or excessive wear of parts.

WARRANTY POLICY

PARMA COMPANY warrants to each purchaser from an authorized dealer of new equipment manufactured by PARMA COMPANY, that such equipment is, at the time of delivery to such purchaser, free from defects in material and workmanship under normal use, if serviced in accordance with the recommendations of the Operator's Manual. All PARMA COMPANY'S *harvesting equipment products* are warranted for 120 days from the first day of use or 800 acres, whichever occurs first. All PARMA COMPANY *soil preparation* products are warranted for 120 days from first day of use or 1600 acres, whichever occurs first. All PARMA COMPANY *water and waste pump products* are warranted for one year from date of purchase. Warranty on defective parts purchased by PARMA COMPANY or produced by other manufacturers for PARMA COMPANY may be allowed only after the approval of the vendor or manufacturer.

PARMA COMPANY'S obligation under this warranty is limited to repairing, or at it's option, replacing any part, that in PARMA COMPANY'S judgment, proved defective. Under the terms of the warranty, PARMA COMPANY assumes no responsibility for labor or travel costs involved in removal of defective parts, of installation of new parts, or of any shop supplies or service charges.

All warranty claims are to be initiated through the authorized PARMA COMPANY dealer and **must be submitted within 30 days of the date of failure**. PARMA COMPANY may ask for defective parts to be returned to the factory; therefore, hold all warranty claim parts until advised if the parts are needed by your dealer.

To make the warranty effective, the owner's **Warranty Registration Form** must be on file at PARMA COMPANY, Parma, Idaho at the time of receipt of the warranty claim.

DISCLAIMER OF ALL OTHER WARRANTIES AND CONSEQUENTIAL DAMAGES

THE FOREGOING IS IN LIEU OF ALL OTHER WARRANTIES, WHETHER EXPRESSED OR IMPLIED, INCLUDING ANY IMPLIED WARRANTY OF MERCHANTABILITY OR FITNESS FOR A PARTICULAR PURPOSE, AND THERE ARE NO WARRANTIES, WHICH EXTEND BEYOND THE DESCRIPTION OF THE PRODUCTS. THE LIABILITY OF PARMA COMPANY IS EXPRESSLY LIMITED TO REPAIRING, OR AT ITS OPTION, REPLACING ANY PART THAT IS RETURNED, TRANSPORTATION PREPAID, TO PARMA COMPANY, PARMA, IDAHO, THAT IN PARMA'S JUDGEMENT PROVED DEFECTIVE DURING THE WARRANTY PERIOD. NO REPRESENTATIVE OF PARMA COMPANY, NO DEALER OR DEALER'S REPRESENTATIVE OR ANY OTHER PERSON HAS AUTHORITY TO WAIVE, ALTER, VARY OR ADD TO THE TERMS HEREOF WITHOUT PRIOR APPROVAL IN WRITING SIGNED BY AN OFFICER OF PARMA COMPANY. PARMA COMPANY WILL NOT BE LIABLE FOR ANY OTHER EXPENSE, INJURY, LOSS OR DAMAGE WHETHER DIRECT OR CONSEQUENTIAL, ARISING IN CONNECTION WITH THE SALE OR USE OF OR INABILITY TO USE, ANY PRODUCT OF THE COMPANY FOR ANY PURPOSE.

MAINTENANCE AND FIELD ADJUSTMENTS

HIGHWAY TRANSPORT

When transporting the Parma Land Plane with a tractor, the top link of the tractor 3-point hitch **MUST** be disconnected; otherwise, the hitch will be damaged when the limits of the hitch are exceeded. Insert the center lock pin on the self-leveling hitch to maximize blade clearance in transport and for support when parking the land plane (Figure 1).

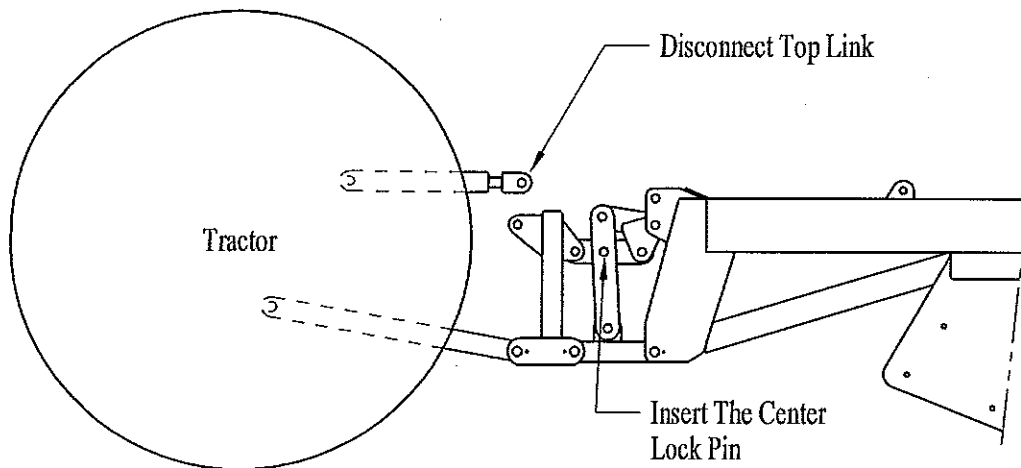

Figure 1.

FIELD SETUP

- Before operating, reconnect the tractor top link and remove the center lock-pin on the self-leveling hitch. Adjust the leveling blade height with the tractor's 3-point hydraulic control. This will determine the load that will be carried in the bucket. The recommended load is to have the bucket 2/3 full in operation.
- After the blade height has been set, adjust the tractor 3-point so the horizontal lift bar on the land plane is parallel to the ground. This is required to obtain the maximum compensation (travel) in leveling. Whenever the working height of the blade is changed, the center link should be readjusted to keep the lift bar parallel to the ground (Figure 2).

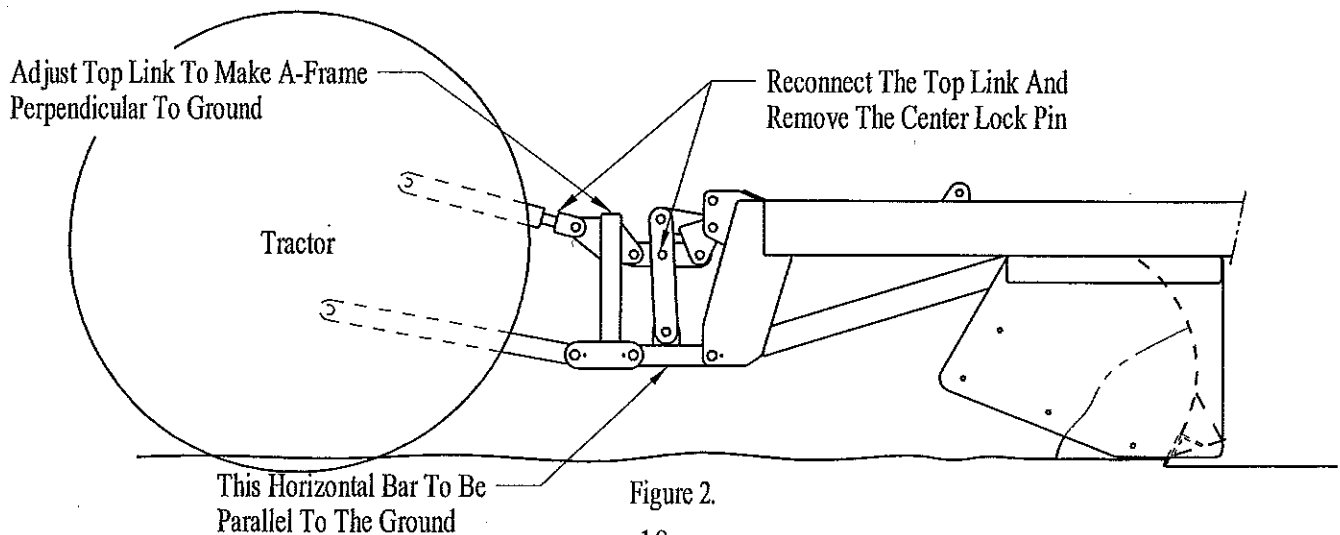

Figure 2.

Field Setup Cont....

- The top link of the tractor 3-point should now be adjusted so that the A-frame of the self-leveling hitch is perpendicular to the ground. This is necessary to get the maximum compensation (travel) in leveling.
- The left rear wheel bracket is adjustable. Adjust this bracket up or down as necessary for final side-to-side depth setting of the leveling blade (Figure 3).

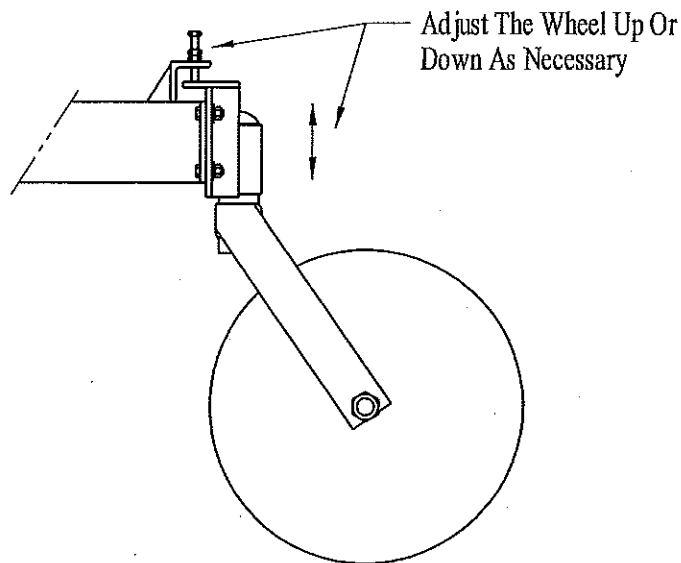

Figure 3.

REAR WHEEL ADJUSTMENT

The width of the rear wheel tread can be adjusted while in motion but should not extend past the bucket ends. This allows wide lateral stability when land leveling and narrow tread width while turning in a corner or along a ditch or levee.



WARNING: The self-leveling hitch should be examined for damage if:

- The leveling blade goes to maximum cut and remains there.
- The self-leveling hitch does not compensate for ground variations

S-TINE ATTACHMENT

Under normal usage, the S-Tines may last for several years. Each S-Tine has a removable point that is reversible. Inspect these points regularly to see that they do not wear excessively. Before the worn end reaches the S-Tine, reverse the point for double wear. Always replace the point before damage to the S-Tine occurs. Check bolt tightness regularly to prevent the tines from moving or sliding.



SAFETY... YOU CAN LIVE WITH IT

FOLDING MODELS

- The bucket wings, on the folding models, can be raised and lowered with hydraulic cylinders. When in the down position, they are mechanically locked rigid for land leveling. When lowering the bucket wings, be sure that the center bucket section is clear off the ground so that dirt is not trapped between the bucket sections. Dirt will prevent the buckets from lining up and forcing the wings down will damage the bucket lift mechanism.
- ALWAYS MAKE SURE ALL THREE LEVELING BLADES ARE IN ALIGNMENT BY SIGHTING DOWN THE BOTTOM EDGE OF THE BLADES.
- The large turnbuckles on each wing lock must be adjusted to level the wings with the center and hold the bucket wings down tight when in a locked position. There are two adjusting screws on each lift lock that are used to adjust the hydraulic cylinder stroke to lock the hydraulic cylinder pins about 1/8" to 1/4" past center (Figure 4). This will hold the bucket wings in a locked position with no pressure on the hydraulic lines.
-  The bucket wings are equipped with safety links on each bucket. They must be used when the bucket wings are in the raised position before attempting to transport. This will prevent accidental lowering of the bucket wings.

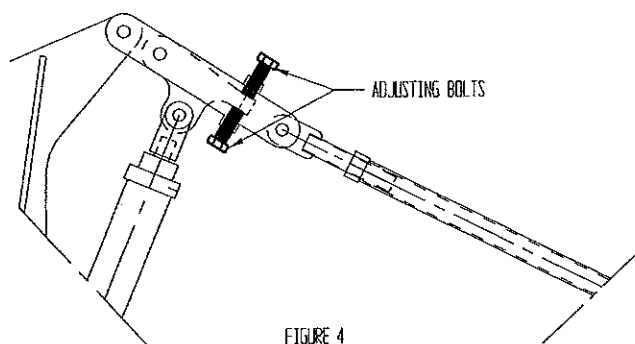

LUBRICATION

Lubrication points are located at pivot points at the self-leveling hitch, trailing and spreader arms, and at the rear wheel pivot bearings. Grease these items daily, with the exception of the floating hitch which requires greasing three(3) times per day.

Repack the carrier wheel hub bearings at the beginning of each season.

DITCHES AND OTHER OBSTACLES

 Traversing ditches with the Parma Land Plane that are over three feet wide and twelve inches deep, or crossing over levees over twelve inches high and at a ninety-degree angle to the ditch or levee **SHOULD BE AVOIDED**. If this is not possible to avoid, the top link on the tractor 3-point should be disconnected to prevent the self leveling hitch from exceeding its travel limits and being damaged. It is recommended in crossing a ditch or levee that the tractor and land plane approach at an approximate 45° angle to allow the self-leveling hitch to operate most efficiently.

SAFETY.... YOU CAN LIVE WITH IT



PARMA[®]

Land Plane

PARTS SECTION

TABLE OF CONTENTS

CASTER WHEEL ASSEMBLY.....	10
DECAL GROUP.....	15
DUAL CASTER WHEEL ASSEMBLY.....	12
FRAME ASSEMBLIES, RIGID.....	4
FRAME ASSEMBLY, FOLDING.....	6
HITCH ASSEMBLY.....	2
S-TINE ATTACHMENT-RIGID FRAME.....	13
S-TINE ATTACHMENT-FOLDING FRAME.....	14
WING ASSEMBLIES.....	8

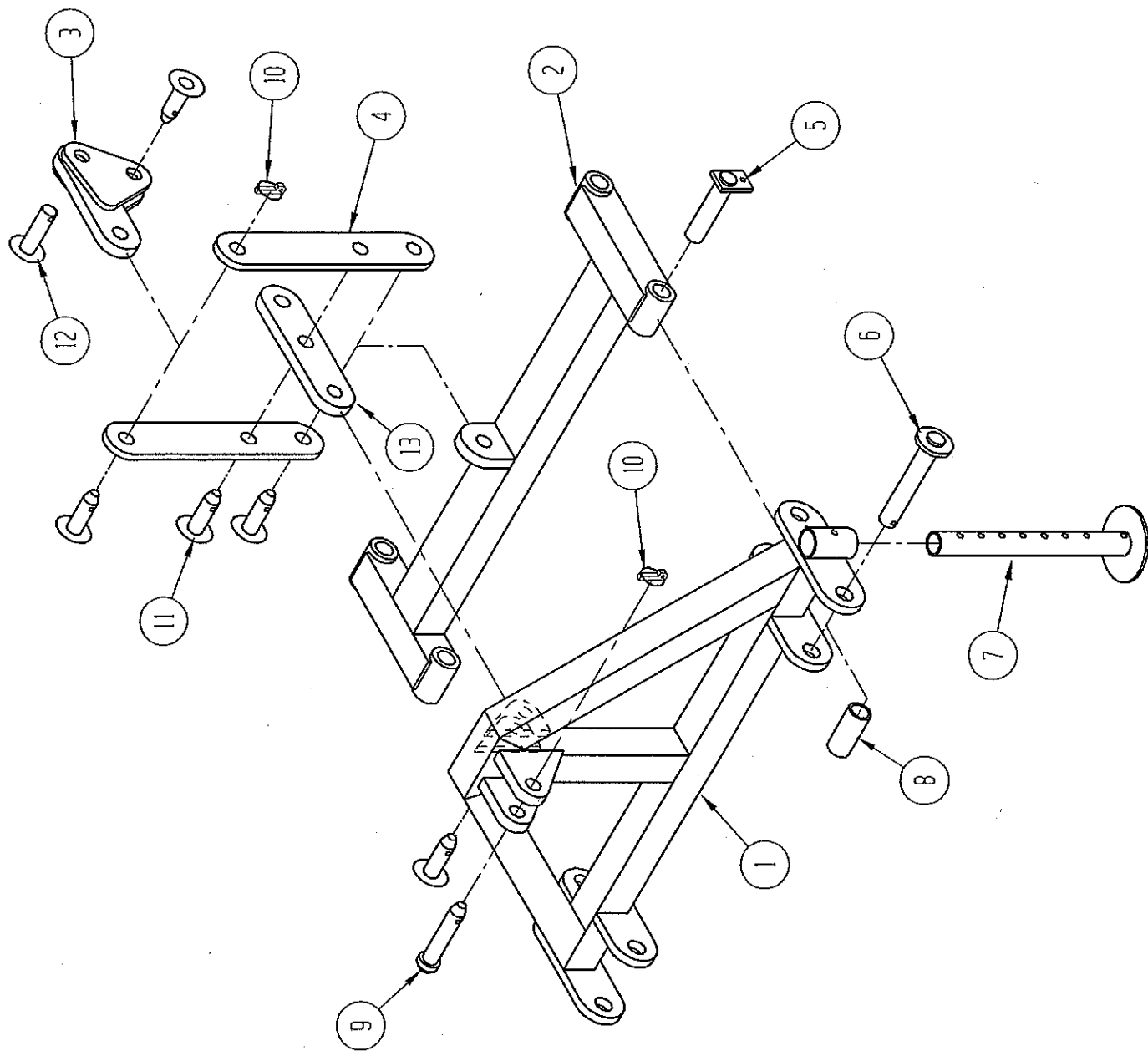

HITCH ASSEMBLY

ITEM NO.	QUANTITY	PART NO.	DESCRIPTION
1	1	510623	Front Hitch
2	1	510622	Intermediate Hitch
3	1	510624	Top Link
4	2	510696	Vertical Link
5	4	510053	Hitch Pin
6	2	510719	Hitch Pin, Lower Link
7	2	230211	Jack Stand
8	2	510721	Lower Link Spacer
9	1	510723	Hitch Pin, Top Link
10	6	530053	Lynch Pin, 3/8
11	5	510058	Linkage Pin
12	1	510056	Linkage Pin, Top
13	1	510695	Middle Link

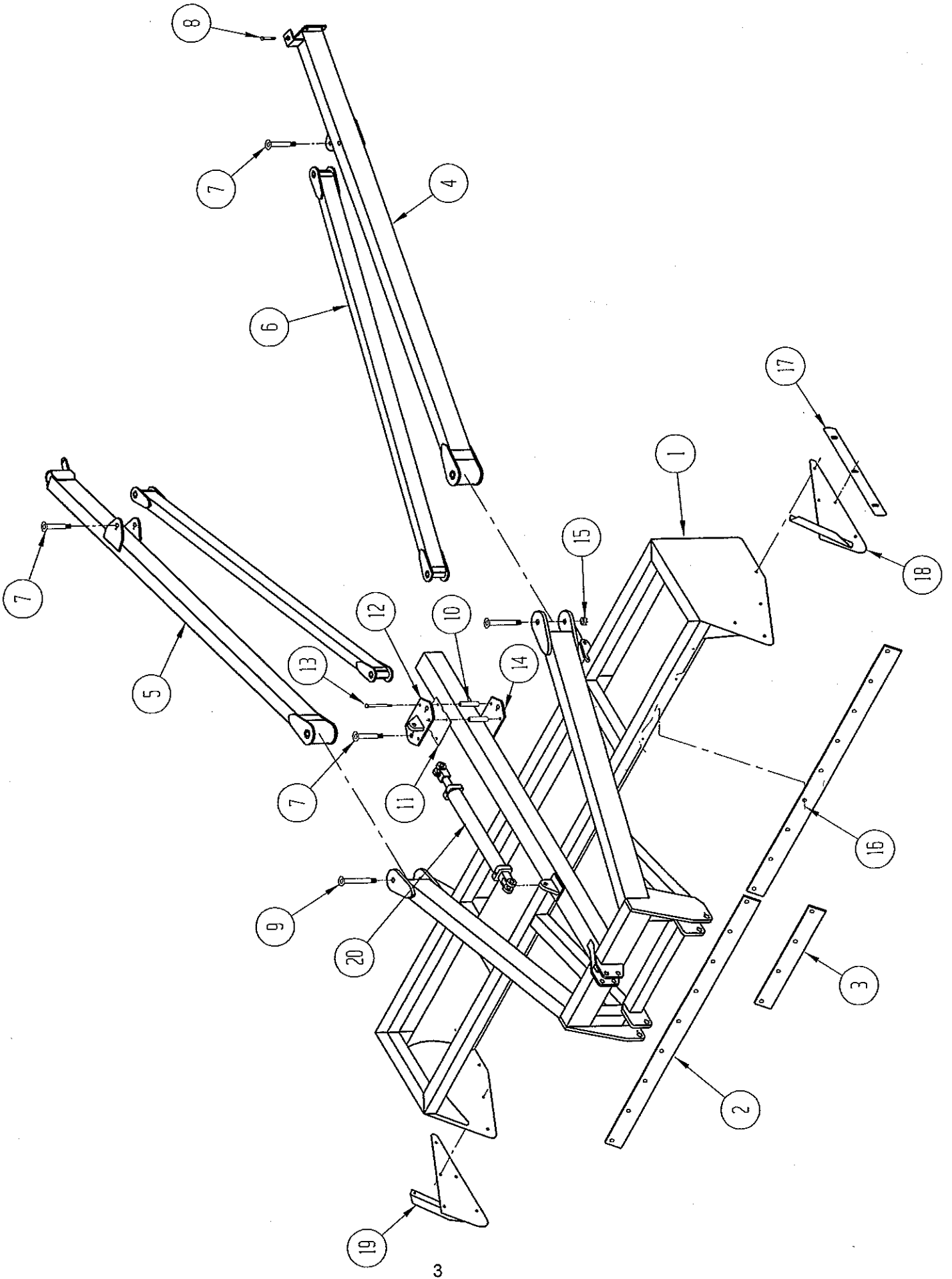

FRAME ASSEMBLY, RIGID

ITEM NO.	QTY.	PART NO.	PART NO.	PART NO.	PART NO.	DESCRIPTION
		14 FT.	16 FT.	20 FT.	24 FT.	
1	1	510738	510083	510009	510769	Main Frame
2	2	510739	510072	510072		Scraper Blade
	3				510072	Scraper Blade
3	1			510048		Scraper Blade, 20' Only
4	1	510041	510041	510041	510041	LH Trailing Arm
5	1	510042	510042	510042	510042	RH Trailing Arm
6	2	510609	510609	510609	510609	Spreader Arm
7	4	510619	510619	510619	510619	Spreader Arm Pin
8	1	510061	510061	510061	510061	Adjusting Bolt
9	2	510790	510790	510790	510790	Trailing Arm Pin
10	4	510613	510613	510613	510613	Pipe Spacer
11	1	510055	510055	510055	510055	Wear Plate, UHMW
12	1	510611	510611	510611	510611	Slide Plate Weldment
13	4					Hex Bolt, 5/8 x 8 Grd 5
14	1	510612	510612	510612	510612	Slide Plate
15	2	510785	510785	510785	510785	Slotted Nut, 1 1/4 NC
16	As Req'd					Plow Bolt, 1/2 x 1 3/4
17	2	510625	510625	510625	510625	Wear Bar
18	1	510615	510615	510615	510615	LH Wear Plate Support
19	1	510616	510616	510616	510616	RH Wear Plate Support
20	1	510075	510075	510075	510075	Hyd. Cylinder, 3/8 x 36

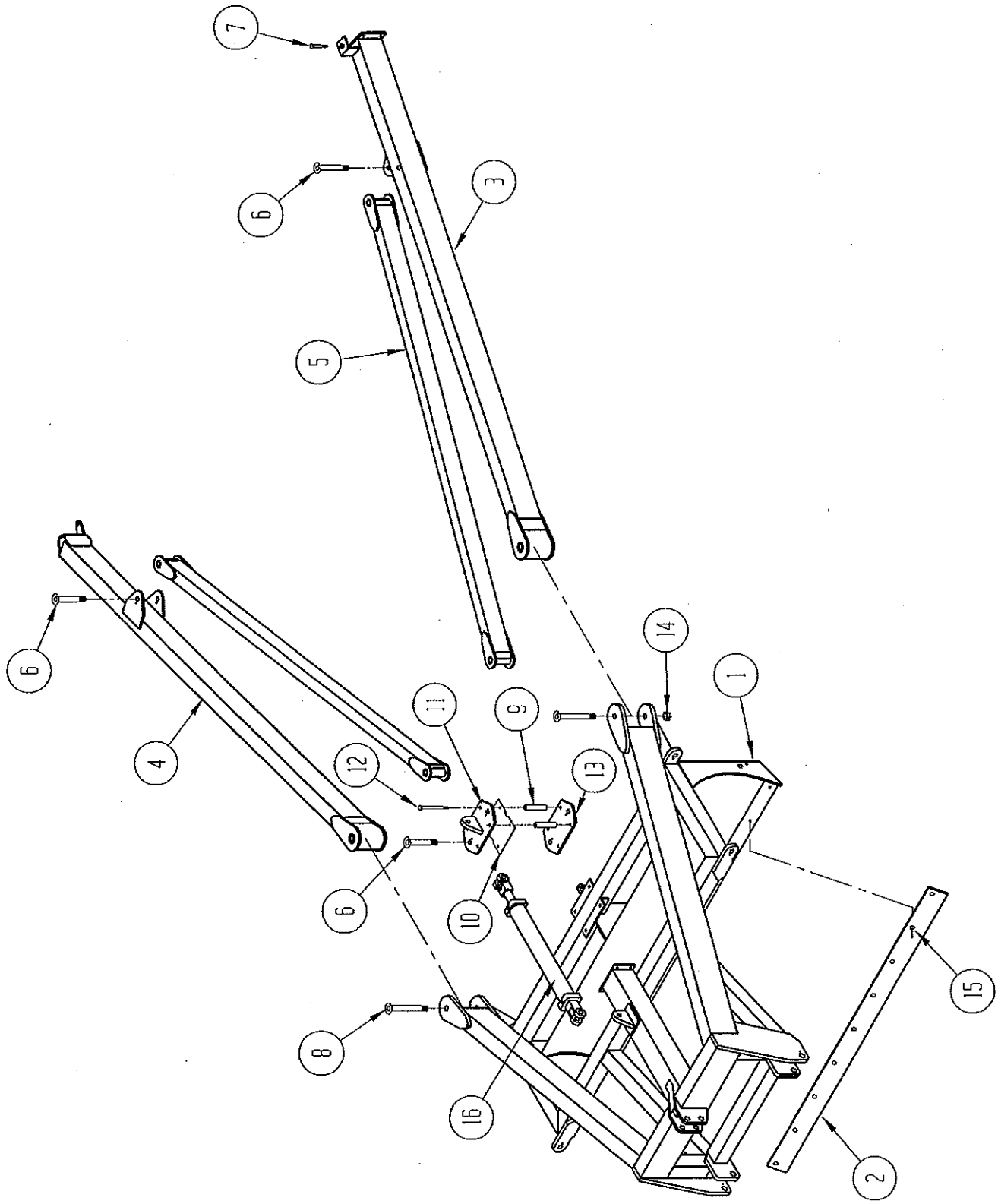

FRAME ASSEMBLY, FOLDING

ITEM NO.	QUANTITY	PART NO.	DESCRIPTION
1	1	510603	Center Frame
2	1	510072	Scraper Blade
3	1	510041	LH Trailing Arm
4	1	510042	RH Trailing Arm
5	2	510609	Spreader Arm
6	4	510619	Spreader Arm Pin
7	1	510061	Adjusting Bolt
8	2	510790	Trailing Arm Pin
9	4	510613	Pipe Spacer
10	1	510055	Wear Plate, UHMW
11	1	510611	Slide Plate Weldment
12	4		Hex Bolt, 5/8 x 8 GRD 5
13	1	510612	Slide Plate
14	2	510785	Slotted Nut, 1 1/4 NC
15	As Req'd		Plow Bolt, 1/2 x 1 3/4
16	1	510075	Hydraulic Cylinder, 3 x 36

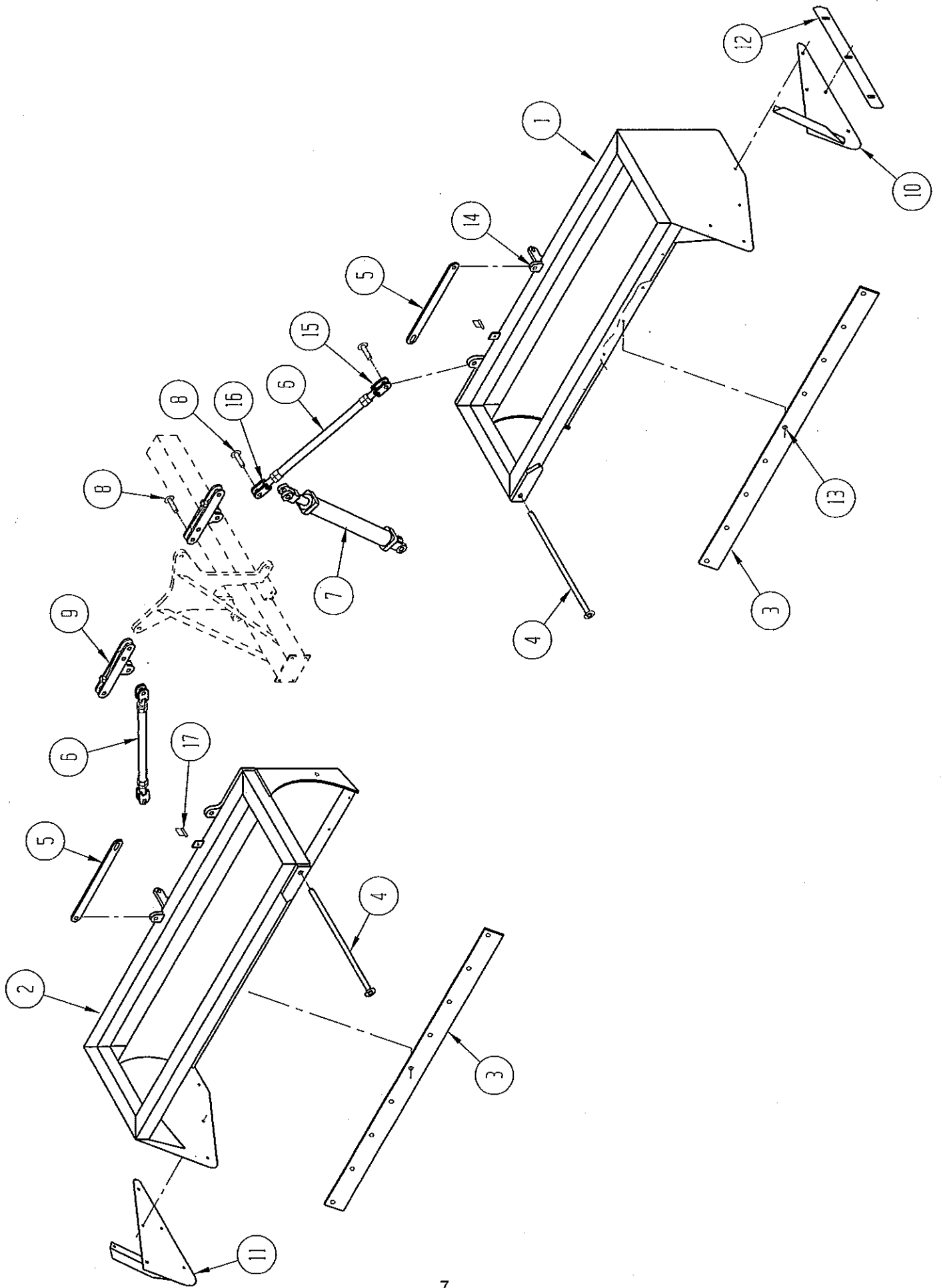

WING ASSEMBLIES

ITEM NO.	QUANTITY	PART NO.			DESCRIPTION
		20 Ft.	24 Ft.	26 Ft.	
1	1	510088	510066	510807	LH Wing
2	1	510089	510071	510806	RH Wing
3	2	510093		510811	Scraper Blade
	2		510072		Scraper Blade
4	2	510620	510620	510620	Wing Pivot Pin
5	2	510781	510781	510781	Down Stop Link
6	2	510617	510617	510617	Adjustable Link
7	2	510074	510074	510074	Hydraulic Cylinder, 3 1/2 x 12
8	6	510621	510621	510621	Linkage Pin
9	2	510610	510610	510610	Cylinder Link
10	1	510615	510615	510615	LH Weart Plate Support
11	1	510616	510616	510616	RH Wear Plate Support
12	2	510625	510625	510625	Wear Plate
13	As Req'd				Plow Bolt, 1/2 x 1 3/4
14	2	510805	510805	510805	Hex Bolt, 1 x 3 NC Full Thread
15	2	510677	510677	510677	LH Clevis
16	2	510678	510678	510678	RH Clevis
17	2	520071	520071	520071	Safety Latch Pin

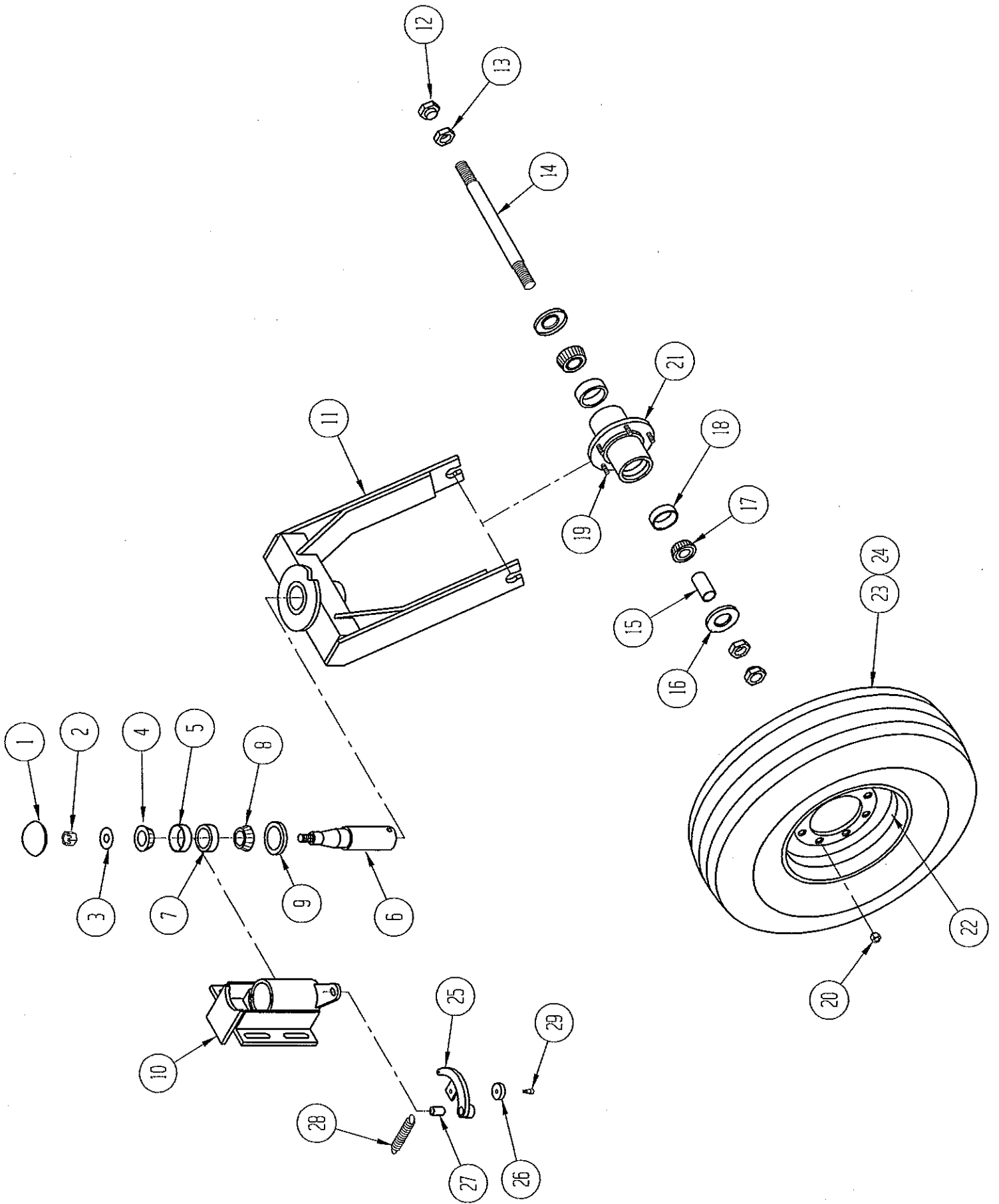

CASTER WHEEL ASSEMBLY

(Two Req'd Per Machine)

ITEM NO.	QUANTITY	PART NO.	DESCRIPTION
1	1	999952	Hub Cap
2	1	999960	Slotted Nut, 7/8
3	1	999965	Flat Washer, 7/8
4	1	360124	Bearing Cone
5	1	360125	Bearing Cup
6	1	360111	Spindle
7	1	360127	Bearing Cup
8	1	360126	Bearing Cone
9	1	510728	Grease Seal
10	1	510726	Wheel Bracket
11	1	510798	Wheel Fork
12	2	331274	Shoulder Nut
13	2	331273	Jam Nut
14	1	360115	Axle
15	2	360128	Axle Bushing
16	2	334902	Grease Seal
17	2	334136	Bearing Cone
18	2	334276	Bearing Cup
19	5	330396	Wheel Stud
20	5	330417	Lug Nut
21	1	334449	Wheel Hub Assembly
22	1	337662	Wheel Rim, 5 Bolt
23	1	999974	Tire, 11L x 15
24	1	999974.99	Tube, 11L x 15
25	1	510753	Lock Out Arm
26	1	337990	Roller
27	1	510756	Lock Out Bushing
28	1	510757	Lock Out Spring
29	1	510758	Shoulder Bolt, 3/8x1/2 Allen Hd.

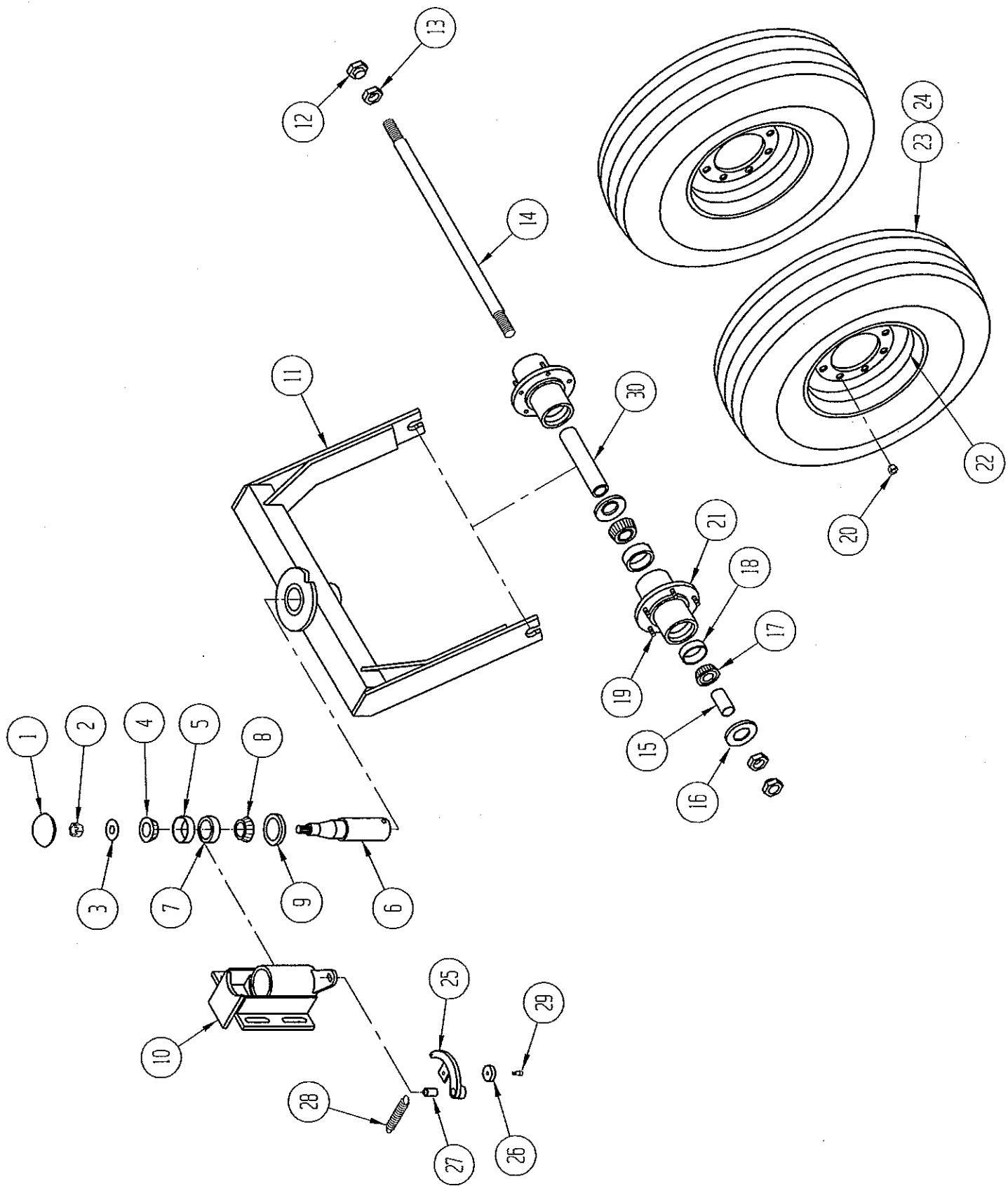

DUAL CASTER WHEEL ASSEMBLY

(Optional)

ITEM NO.	QUANTITY	PART NO.	DESCRIPTION
1	1	999952	Hub Cap
2	1	999960	Slotted Nut, 7/8
3	1	999965	Flat Washer, 7/8
4	1	360124	Bearing Cone
5	1	360125	Bearing Cup
6	1	360111	Spindle
7	1	360127	Bearing Cup
8	1	360126	Bearing Cone
9	1	510728	Grease Seal
10	1	510726	Wheel Bracket
11	1	510802	Dual Wheel Fork
12	2	331274	Shoulder Nut
13	2	331273	Jam Nut
14	1	510765	Dual Axle
15	2	360128	Axle Bushing
16	4	334902	Grease Seal
17	4	334136	Bearing Cone
18	4	334276	Bearing Cup
19	10	330396	Wheel Stud
20	10	330417	Lug Nut
21	2	334449	Wheel Hub Assembly
22	2	337662	Wheel Rim, 5 Bolt
23	2	999974	Tire, 11L x 15
24	2	999974.99	Tube, 11L x 15
25	1	510753	Lock Out Arm
26	1	337990	Roller
27	1	510756	Lock Out Bushing
28	1	510757	Lock Out Spring
29	1	510758	Shoulder Bolt, 3/8x1/2 Allen Hd.
30	1	510776	Bushing

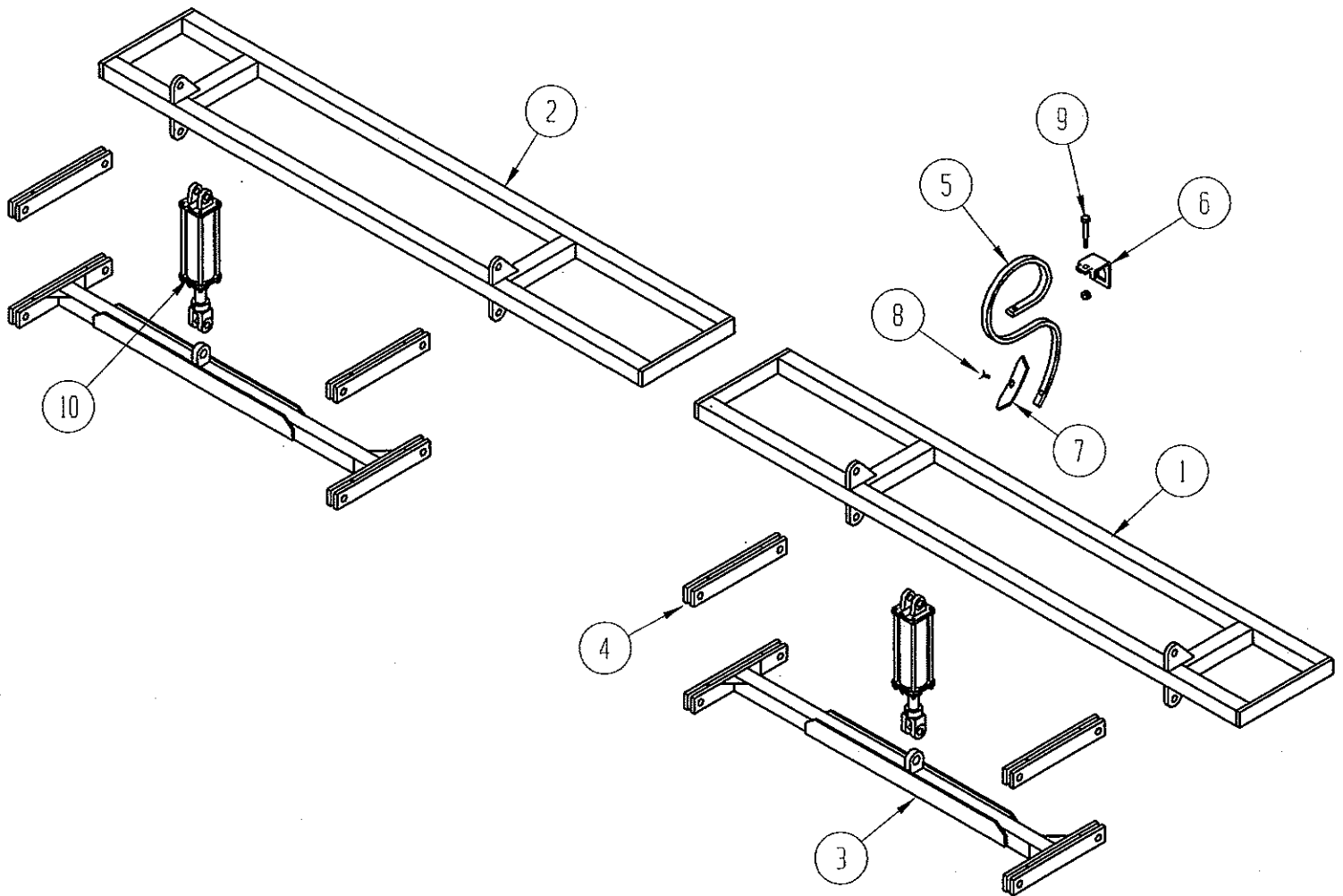

S-TINE ATTACHMENT - RIGID FRAME

ITEM NO.	QTY.	PART NO. 14 FT.	PART NO. 16 FT.	PART NO. 20 FT.	PART NO. 24 FT.	DESCRIPTION
1	2		510086	510033	510780	Tine Bar Frame
1	1	510746				LH Tine Bar Frame
2	1	510747				RH Tine Bar Frame
3	2	510084	510084	510034	510034	Lift Bar
4	4	510628	510628	510628	510628	Link
5	14	521483				S-Tine, HD
	16		521483			S-Tine, HD
	20			521483		S-Tine, HD
	24				521483	S-Tine, HD
6	-	521485	521485	521485	521485	S-Tine Clamp
7	-	521484	521484	521484	521484	Chisel Point
8	-	530052	530052	530052	530052	Cultivator Bolt, 3/8 x 1 1/2
9	-					Hex Bolt, 7/16 x 3 1/2
10	2	998900	998900	998900	998900	Hydraulic Cylinder, 3" x 4"

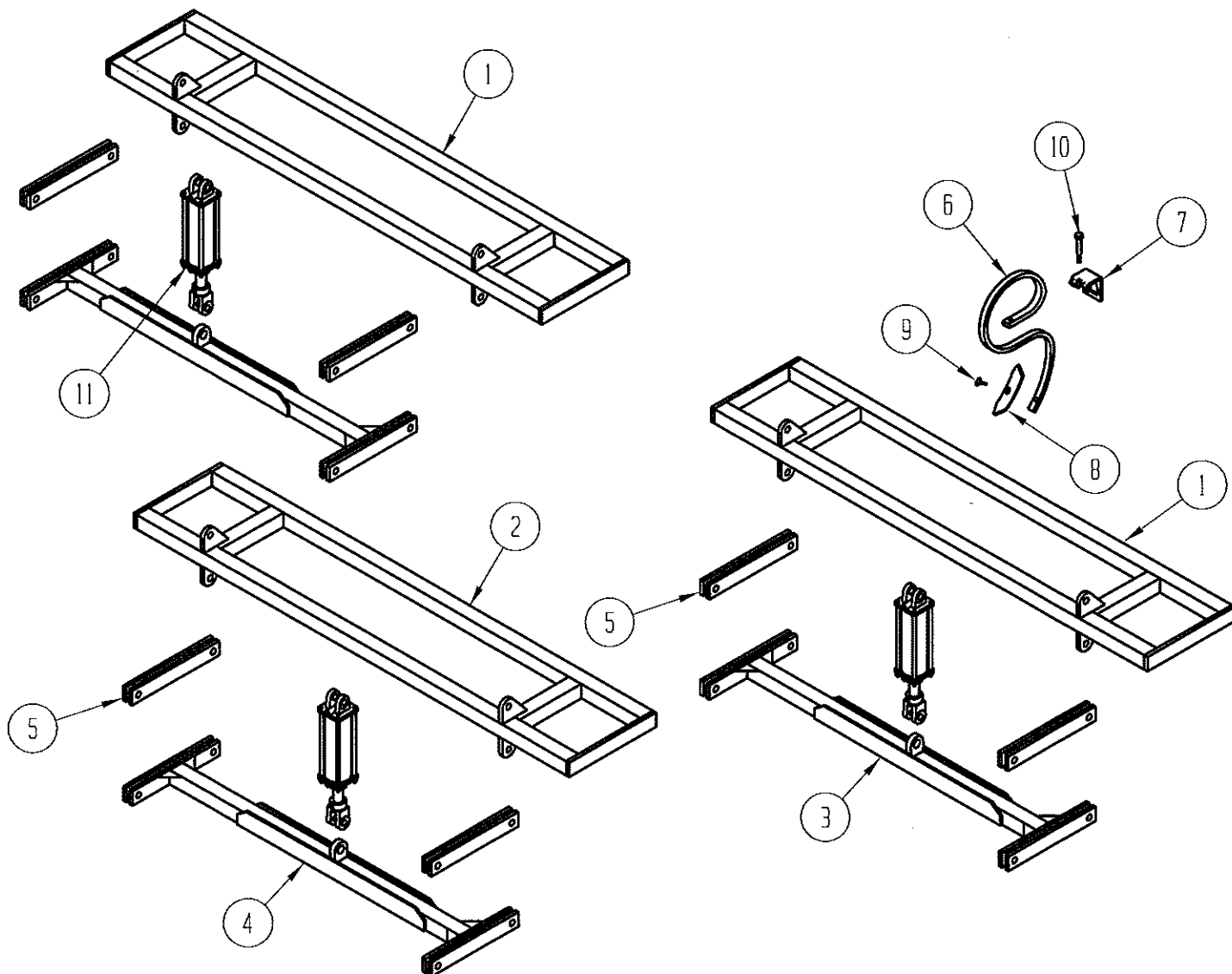

S-TINE ATTACHMENT-FOLDING FRAME

ITEM NO.	QTY.	PART NO.			DESCRIPTION
		20 FT.	24 FT.	26 FT.	
1	2	510095	510626	510814	Tine Bar Frame
2	1	510626	510626	510626	Center Tine Bar Frame
3	2	510094	510627	510627	Lift Bar
4	1	510627	510627	510627	Center Lift Bar
5	6	510628	510628	510628	Link
6	20	521483			S-Tine, HD
	24		521483		S-Tine, HD
	25			521483	S-Tine, HD
7	-	521485	521485	521485	S-Tine Clamp
8	-	521484	521484	521484	Chisel Point
9	-	510088	510066	510066	Cultivator Bolt, 3/8 x 1 1/2
10	-				Hex Bolt, 7/16 x 3 1/2
11	3	998900	998900	998900	Hydraulic Cylinder, 3" x 4"

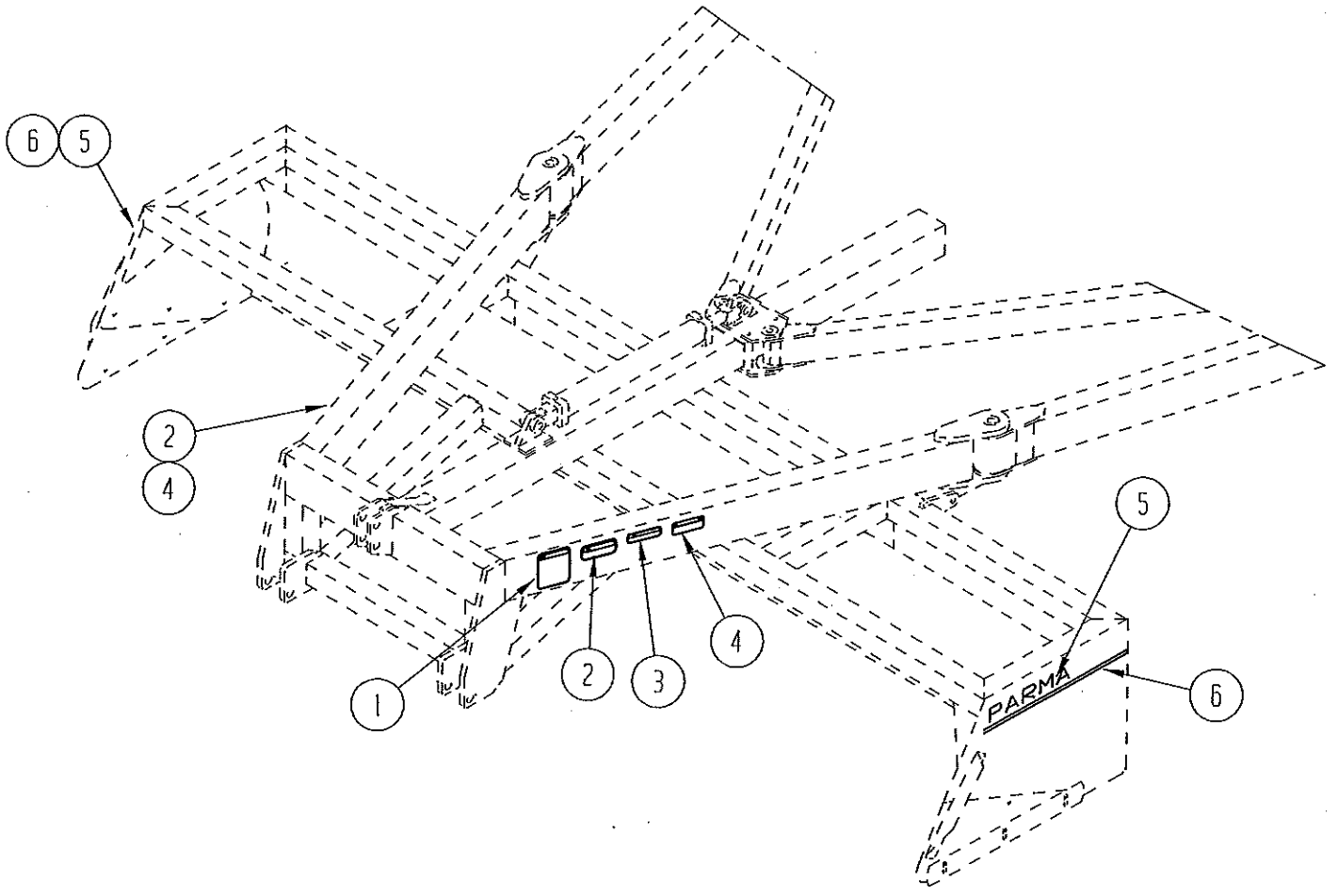

DECAL GROUP

ITEM NO.	QUANTITY	PART NO.	DESCRIPTION
1	1	100406	Decal, General Caution
2	2	100404	Decal, Warning Block The Machine
3	1	100408	Decal, Warning Hydraulic Fluid
4	2	265933	Decal, Do Not Ride
5	2	264797	Decal, Parma
6	5	264798	Decal Stripe Tape

NOTES