

PARMA[®]

Model 264
Beet Defoliator
OPERATOR'S MANUAL/PARTS CATALOG

Manual Number 01292013-DEFOL

PARMA COMPANY

P.O. BOX 190
PARMA, IDAHO 83660
PHONE (208) 722-5116 FAX (208) 722-6012
website: www.parmacompany.com



TABLE OF CONTENTS

BELT TENSIONING.....	20
BOLT TORQUE	12
CUSTOMER AND DEALER CHECKLIST	8
DEALER TEST RUN AND FINAL CHECK.....	15
FIELD ADJUSTMENTS	16
FLAIL HEIGHT ADJUSTMENT	16
FLAIL ROTATION.....	16
INTRODUCTION.....	1
LUBRICATION AND SERVICE SCHEDULE	11
MAINTENANCE/SERVICE INFORMATION	11
PARTS REPLACEMENT SECTION	21
SAFETY PRECAUTIONS.....	2
SAFETY SIGN LOCATIONS.....	4
SCALPING ADJUSTMENTS, UNPOWERED DISK	17
SCALPING ADJUSTMENTS, HYDRAULIC DISK.....	19
SCALPING ADJUSTMENTS, KNIFE.....	16
SET-UP PROCEDURE	13
WARRANTY POLICY	10

INTRODUCTION

This manual has been prepared to acquaint you with the operation and maintenance of your **PARMA Model 264 Defoliator**, and to provide important safety information. We urge you to read this manual carefully. The recommendations will help assure the safe and trouble free operation of your machine.

When it comes to service, keep in mind that your dealer knows your Defoliator well and is interested in your complete satisfaction. Your dealer invites you to call him for your service needs both during and after the warranty period.

We thank you for choosing a PARMA product and want to assure you of our continuing interest in your satisfaction. You have purchased a very good machine and with proper care it will give you good service.



SAFETY: THE MOST IMPORTANT SUBJECT OF ALL...YOU CAN LIVE WITH IT!

The Following safety instructions are provided to help assure that all operators of this equipment are trained in its operation and are familiar with the importance of safety in its use.



WITH OWNERSHIP COMES RESPONSIBILITY!

Many times the owner of this equipment is not the operator. The manufacturer delivers the equipment to a dealer, who in turn sells it to an owner. The owner may then assign another person to operate it. With each of these steps it is the duty of the one in possession of the equipment to be sure that the safe operation of the machine is fully explained to the person, or persons, actually operating it. **Do not allow this machine to be used until the following safety material has been reviewed.**

REMEMBER: One of the most common cause of injury or death around this type of equipment is because the operator does not shut the tractor engine off and remove the key when maintenance, adjustments, or cleaning of the machine is conducted!



SAFETY... YOU CAN LIVE WITH IT!

SAFETY PRECAUTIONS

TAKE NOTE! THIS SAFETY ALERT SYMBOL FOUND THROUGH OUT THIS MANUAL IS USED TO CALL YOUR ATTENTION TO INSTRUCTIONS INVOLVING YOUR PERSONAL SAFETY AND THE SAFETY OF OTHERS. FAILURE TO FOLLOW THESE INSTRUCTIONS CAN RESULT IN INJURY OR DEATH.

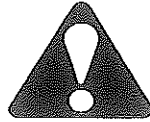

THIS SYMBOL MEANS

-ATTENTION!

-BECOME ALERT!

- YOUR SAFETY IS INVOLVED!

SIGNAL WORDS:

Note the use of the signal words **DANGER**, **WARNING** and **CAUTION** with the safety messages. The appropriate signal word for each has been selected using the following guidelines:

DANGER: Indicates an imminently hazardous situation that, if not avoided, will result in death or serious injury. This signal word is to be limited to the most extreme situations typically for machine components for which functional purposes cannot be guarded.

WARNING: Indicates a potentially hazardous situation that, if not avoided, could result in death or serious injury, and includes hazards that are exposed when guards are removed. It may also be used to alert against unsafe practices.

CAUTION: Indicates a potentially hazardous situation that, if not avoided, may result in minor or moderate injury. It may also be used to alert against unsafe practices.

If you have questions not answered in this manual or require additional copies or the manual is damaged, please contact your dealer.

SAFETY... YOU CAN LIVE WITH IT



SAFETY... YOU CAN LIVE WITH IT



EQUIPMENT SAFETY GUIDELINES

Safety of the operator is one of the main concerns in designing and developing a new piece of equipment. Designers and manufacturers build in as many safety features as possible. However, every year many accidents occur which could have been avoided by a few seconds of thought and a more careful approach to handling equipment. You, the operator, can avoid many accidents by observing the following precautions in this section. To avoid personal injury, study the following precautions and insist those working with you, or for you, follow them.

In order to provide maximum safety to the operator or other persons around this machine, various shields and covers have been installed. Keep all shields and covers in place. If shield removal becomes necessary for repairs or any other reason, replace the shield prior to use.

Replace any CAUTION, WARNING, DANGER or instruction safety decal that is not readable or is missing. Location of such decals is indicated in this manual.

Do not attempt to operate this equipment under the influence of drugs or alcohol.

Review the safety instructions with all users annually.

This equipment is dangerous to children and persons unfamiliar with its operation. The operator should be a responsible adult familiar with farm machinery and trained in this equipment's operations. **Do not allow persons to operate or assemble this unit until they have read this manual and have developed a thorough understanding of the safety precautions and of how it works.**

Do not paint over, remove or deface any safety signs or warning decals on your equipment. Observe all safety signs and practice the instructions on them.

Never exceed the limits of a piece of machinery. If its ability to do a job, or to do so safely is in question – **DON'T TRY IT.**



LIGHTING AND MARKING

It is the responsibility of the customer to know the lighting and marking requirements of the local highway authorities and to install and maintain the equipment to provide compliance with the regulations. Add extra lights when transporting at night or during periods of limited visibility.

Lighting kits are available from your dealer or from the manufacturer.

SAFETY SIGN LOCATIONS

The types of Safety Signs on the equipment are shown below. Their locations are shown on in the parts section of this manual. Good safety requires that you familiarize yourself with the various Safety Signs, the type of warning and the area, or particular function related to that area that requires your SAFETY AWARENESS.

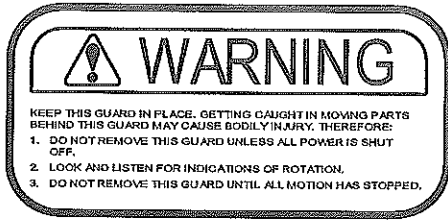

Part #100409

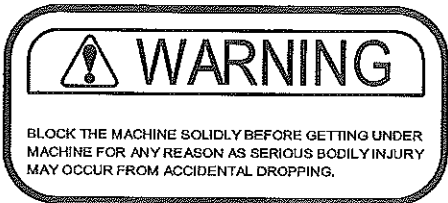

Part #100404

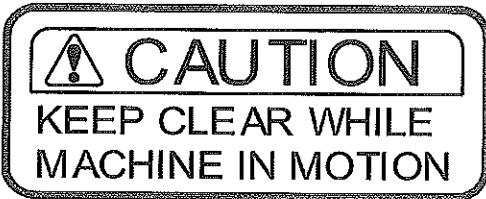

Part #100564

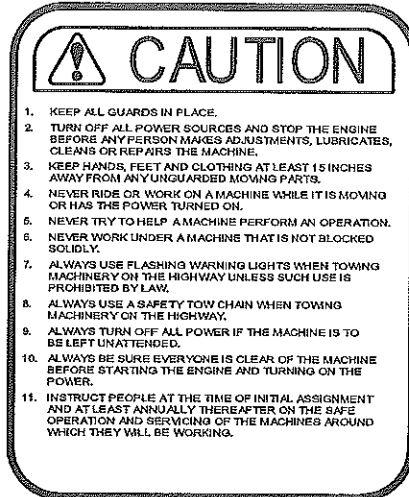

Part #100406



Part #100311

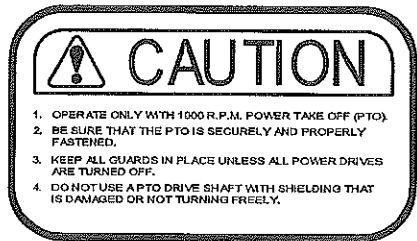

Part #100405



Part #100565

REMEMBER: If Safety Signs have been damaged, removed, become illegible or parts replaced without decals, new decals must be applied. New decals are available from your authorized dealer or manufacturer.



SAFETY SIGN CARE

- Keep safety signs clean and legible at all times
- Replace safety signs that are missing or have become illegible
- Replaced parts that displayed a safety sign should also display the current sign
- Safety signs are available from your Dealer Parts Department or the Manufacturer

How to Install Safety Signs:

- Be sure that the installation area is clean and dry
- Decide on the exact position before you remove the backing paper
- Remove the smallest portion of the split backing paper
- Align the decal over the specified area and carefully press the small portion with the exposed sticky backing in place
- Slowly peel back the remaining paper and carefully smooth the remaining portion of the decal in place
- Small air pockets can be pierced with a pin and smoothed out using the piece of decal backing paper



REMEMBER!

Your best assurance against accidents is a careful and responsible operator. If there is any portion of this manual or function you do not understand, contact your local authorized dealer or the manufacturer.



BEFORE OPERATING:

- Carefully study and understand this manual
- Do not wear loose-fitting clothing which may catch in moving parts
- Always wear protective clothing and substantial shoes
- Assure that agricultural implement tires are inflated evenly
- Inspect the unit for any loose bolts, worn parts or cracked welds, and make necessary repairs. Follow the maintenance safety instructions included in this manual
- Be sure that there are no tools lying on or in the equipment
- Do not use the unit until you are sure that the area is clear, especially children and animals

- Don't hurry the learning process or take the unit for granted. Ease into it and become familiar with your new equipment
- Practice operation of your equipment and its attachments. Completely familiarize yourself and other operators with its operation before using



DURING OPERATION:

- **NO PASSENGERS ALLOWED** – Do not allow any passengers to ride on the equipment at any time
- Keep hands and clothing clear of moving parts
- Do not clean, lubricate or adjust your equipment while it is in motion
- When halting operation, even periodically, disengage the PTO, **shut off the tractor engine and remove the ignition key**
- Be especially observant of the operating area and terrain – watch for holes, rocks or other hidden hazards.
- Do work under raised components or attachments unless securely positioned and blocked
- Keep all bystanders, pets and livestock clear of the work area
- As a precaution, always recheck the hardware on equipment following every 100 hours of operation. Correct all problems. Follow the maintenance safety procedures



FOLLOWING OPERATION:

- Following operation, or when unhitching, stop the tractor, set the brakes, disengage the PTO, **shut off the engine and remove the ignition keys**
- Store the unit in an area away from human activity
- Do not permit children to play on or around the stored unit
- Make sure all parked machines are on a hard, level surface and engage all safety devices



HIGHWAY AND TRANSPORT OPERATIONS:

- Adopt safe driving practices:

Always drive at a safe speed relative to local conditions and ensure that your speed is low enough for an emergency to stop to be safe and secure. Keep speed to a minimum

Reduce speed prior to turns to avoid the risk of overturning



Highway and Transport Operations Cont....

Always keep the tractor in gear to provide engine braking when going downhill. Do not coast

Do not drink and drive!

- Comply with state and local laws governing highway safety and movement of farm machinery on public roads
- Use approved accessory lighting flags and necessary warning devices to protect operators of other vehicles on the highway, during daylight and nighttime transport, in accordance with State Department of Transportation specifications. Various safety lights and devices are available from your Dealer
- The use of flashing amber lights is acceptable in most localities. However, some localities prohibit their use. Local laws should be checked for all highway lighting and marking requirements
- Be a safe and courteous driver. Always yield to oncoming traffic in all situations, including narrow bridges, intersections, etc
- Be observant of bridge loading ratings. Do not cross bridges rated lower than the gross weight at which you are operating
- Watch for obstructions overhead and to the side while transporting
- Always operate equipment in a position to provide maximum visibility at all times.



PERFORMING MAINTENANCE:

- Good maintenance is your responsibility. Poor maintenance is an invitation to trouble
- Before working on this machine, disengage the PTO, **shut off the tractor engine and remove the ignition keys**
- Be certain all moving parts have come to a complete stop before attempting to perform maintenance
- **Always** use a safety support. Never use a jack to support the machine
- Always use the proper tools or equipment for the job at hand
- Use extreme caution when making adjustments
- Follow the torque chart in this manual when tightening bolts and nuts
- Never use your hands to locate a hydraulic leak on attachments. Use a small piece of cardboard or wood. Hydraulic fluid escaping under pressure can penetrate the skin
- When disconnecting hydraulic lines, shut off hydraulic supply and relieve all hydraulic pressure



Performing Maintenance Cont....

- Openings in the skin and minor cuts are susceptible to infection from hydraulic fluid. **If injured by escaping hydraulic fluid, see a doctor at once. Gangrene can result. Without immediate medical treatment, serious infection and reactions can occur**
- Replace **all shields and guards** after servicing and before moving
- After servicing, be sure all tools, parts and service equipment are removed
- Never replace hex bolts with less than grade five bolts unless otherwise specified. Refer to bolt torque chart for head identification marking
- Where replacement parts are necessary for periodic maintenance and servicing, genuine factory replacement parts are recommended to restore your equipment to original specifications. The manufacturer will not claim responsibility for use of unapproved parts and/or accessories and other damages as a result of their use
- If equipment has been altered in any way from original design, the manufacturer does not accept any liability for injury or warranty

CUSTOMER AND DEALER CHECKLIST

After the machine has been completely assembled, inspect it thoroughly to be certain it is in operating condition before delivering it to a customer. The following checklist is a reminder of points to inspect. Check off each item as it is found satisfactory or after proper adjustment is made.

PRE-DELIVERY:

- Check all bolts and nuts to be sure they are tight
- Make sure all bearing lock collars are set correctly and tightened
- Inspect and, if necessary, grease all lubrication points; making sure all bearings are taking grease and check gearbox oil level (See Lubrication & Service Schedule)
- Check all moving parts for smooth operation
- Check to see that all hydraulic fittings and cylinders are tight and free of leaks

DELIVERY:

- Complete the Delivery and Warranty Registration Forms, listing serial number of machine
- Have the dealer and customer sign the form. Explain warranty policy on the Warranty Registration Form, and return to Parma Company.
- Show the customer how to operate the Defoliator
- Explain adjustments
- Explain the importance of proper lubrication
- Give the operator's manual to the customer and ask him to familiarize himself with all sections of it.

DELIVERY CHECKLIST continued:

BEFORE EACH SEASON:

- Check all adjustable components for correct setting
- Perform complete lubrication of machine
- With equipment operating, observe operation of moving parts. Watch for faulty operation, overheated bearings, and unusual sounds
- Read the safety precautions
- Read the operating instructions
- Perform daily checklist

DAILY CHECKLIST: (see Lubrication & Service Schedule)

- Lubricate (as instructed) all lubrication points
- Check Belt Tension (see Belt Tensioning)
- Check flails for wear and damage. Replace as necessary
- Lift top covers and clean inside of machine as necessary
- Look for loose bolts and tighten as necessary
- Check scalper settings and adjust if necessary

WARRANTY POLICY

PARMA COMPANY warrants to each purchaser from an authorized dealer of new equipment manufactured by PARMA COMPANY, that such equipment is, at the time of delivery to such purchaser, free from defects in material and workmanship under normal use, if serviced in accordance with the recommendations of the Operator's Manual. All PARMA COMPANY'S *harvesting equipment products* are warranted for 120 days from the first day of use or 800 acres, whichever occurs first. All PARMA COMPANY *soil preparation* products are warranted for 120 days from first day of use or 1600 acres, whichever occurs first. All PARMA COMPANY *water and waste pump products* are warranted for one year from date of purchase. ALL PARMA COMPANY *forage products* are warranted for one year from date of purchase. Warranty on defective parts purchased by PARMA COMPANY or produced by other manufacturers for PARMA COMPANY may be allowed only after the approval of the vendor or manufacturer.

PARMA COMPANY'S obligation under this warranty is limited to repairing, or at it's option, replacing any part, that in PARMA COMPANY'S judgment, proved defective. Under the terms of the warranty, PARMA COMPANY assumes no responsibility for labor or travel costs involved in removal of defective parts, of installation of new parts, or of any shop supplies or service charges.

All warranty claims are to be initiated through the authorized PARMA COMPANY dealer and must be submitted within 30 days of the date of failure. PARMA COMPANY may ask for defective parts to be returned to the factory; therefore, hold all warranty claim parts until advised if the parts are needed by your dealer.

To make the warranty effective, the owner's **Warranty Registration Form** must be on file at PARMA COMPANY, Parma, Idaho at the time of receipt of the warranty claim.

DISCLAIMER OF ALL OTHER WARRANTIES AND CONSEQUENTIAL DAMAGES

THE FOREGOING IS IN LIEU OF ALL OTHER WARRANTIES, WHETHER EXPRESSED OR IMPLIED, INCLUDING ANY IMPLIED WARRANTY OF MERCHANTABILITY OR FITNESS FOR A PARTICULAR PURPOSE, AND THERE ARE NO WARRANTIES, WHICH EXTEND BEYOND THE DESCRIPTION OF THE PRODUCTS. THE LIABILITY OF PARMA COMPANY IS EXPRESSLY LIMITED TO REPAIRING, OR AT ITS OPTION, REPLACING ANY PART THAT IS RETURNED, TRANSPORTATION PREPAID, TO PARMA COMPANY, PARMA, IDAHO, THAT IN PARMA'S JUDGEMENT PROVED DEFECTIVE DURING THE WARRANTY PERIOD. NO REPRESENTATIVE OF PARMA COMPANY, NO DEALER OR DEALER'S REPRESENTATIVE OR ANY OTHER PERSON HAS AUTHORITY TO WAIVE, ALTER, VARY OR ADD TO THE TERMS HEREOF WITHOUT PRIOR APPROVAL IN WRITING SIGNED BY AN OFFICER OF PARMA COMPANY. PARMA COMPANY WILL NOT BE LIABLE FOR ANY OTHER EXPENSE, INJURY, LOSS OR DAMAGE WHETHER DIRECT OR CONSEQUENTIAL, ARISING IN CONNECTION WITH THE SALE OR USE OF OR INABILITY TO USE, ANY PRODUCT OF THE COMPANY FOR ANY PURPOSE.

MAINTENANCE/SERVICE INFORMATION

Gear Box Service and Lubrication

- The oil level should be maintained at a level to the top of the check hole in the side of the box. Check this level every 100 hours of operation
- Recommended replacement oil is 80W-90 Gear Lube or equivalent

Bearings and Drive Line

- Inspect bearings for wear and heat every 100 hours
- **The Pillow Block and Flanged bearing units are factory pre-lubricated and, therefore, do not require supplemental grease before service life begins. Re-lubrication, when administered correctly, can increase the life of a bearing substantially. Bearing manufacturers recommend that all these bearings are greased daily to weekly, considering the environmental condition that these harvesters are exposed to. NOTE: Over lubrication is a major cause of bearing failures.** Please re-lubricate conservatively. When selecting a bearing lubricant, use any lithium-based NLGI #2 grease
- Inspect all couplers and shafts for a tight secure fit



Always perform maintenance with machine stopped, the tractor engine shut off and the ignition key removed!

LUBRICATION & SERVICE SCHEDULE

	Every 10 Hrs		Every 100 hrs		Seasonal	
Bearings	O			X	O	X
Gear Box				X	O	X
Driveline		X	O	X	O	X
All Bolts & Fasteners				X		X
Wheel Nuts		X				X
Wheel Bearings					O	X
Hydraulic Cylinders				X		X
Lights & Wires		X				X
Hydraulic Lines						X
Belt Tension	O	X				X
U-Joints	O			X	O	X
Flail Loss & Damage		X				
Scalpers	O	X			O	X
Tire Pressure			O	X		
Guards		X				X

O = Service and lubricate as recommended

X = Inspect for wear or damage



AVOID INJURY: Never service machine while running! Follow safety procedures in this manual for service and maintenance

BOLT TORQUE



Factory recommends that **ALL BOLTS AND FASTENERS BE RE-TORQUED AFTER THE FIRST 20 HOURS OF USE**

Checking Bolt Torque

The table shown below gives correct torque values for various bolts and cap screws. Tighten all bolts to the torques specified in the chart unless otherwise noted. Check tightness of bolts periodically, using bolt torque chart as a guide. Replace hardware with the same strength bolt

Torque specifications

Bolt Size	SAE 2	SAE 5	SAE 8
"A"	Torque lb/ft	Torque lb/ft	Torque lb/ft
1/4	6	9	12
5/16	10	19	27
3/8	20	33	45
7/16	30	53	75
1/2	45	80	115
9/16	70	115	15
5/8	95	160	220
3/4	165	290	400
7/8	170	410	650
1	225	630	970

Torque figures indicated above are valid for non-greased or non-oiled threads and heads unless otherwise specified. Therefore, do not grease or oil bolts or cap screws unless otherwise specified in this manual. When using locking elements, increase torque values by 5%.

- Torque value for bolts and cap screws are identified by their head markings

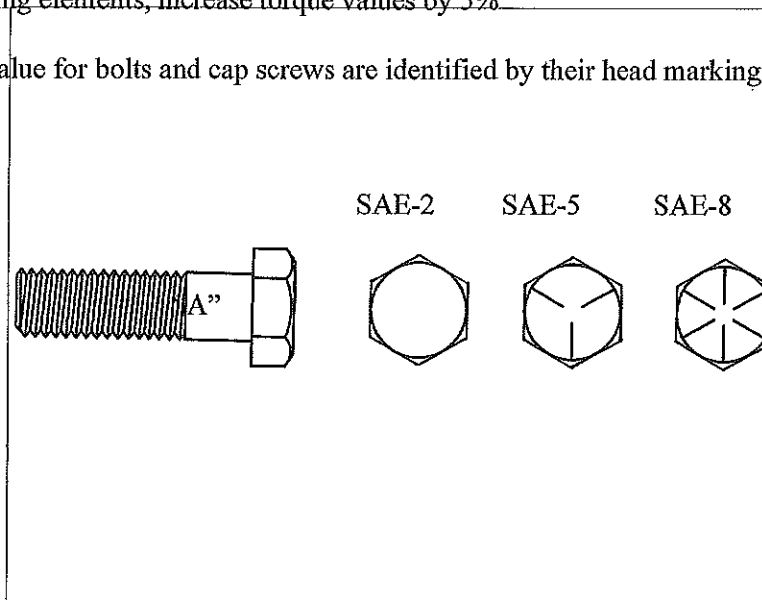

SET-UP PROCEDURE

The Parma Defoliator, commonly, is shipped from the factory completely assembled. If not, the following information will show the usual way the machine is set-up for field use. In any case, even if the machine is factory assembled, be sure to check the machine to be sure the settings are correct for your customer application.



AVOID SERIOUS INJURY – EXERCISE CARE WHEN LIFTING HEAVY PARTS AND MACHINERY DURING THE ASSEMBLY PROCESS

1. Lift the rear end of the defoliator by centering a forklift on the rear 6 x 4 frame tube. Attach the carrier wheel struts to the 6 x 4 tube. If steerable struts are used, attach the strut with the cylinder arm on the LH hand side. See Figure 1 for proper spacing (Note the difference between 24" wheels and 15" wheels. Install the steering cylinder bracket on the 6 x 4 frame tube (15" wheels only) as shown (see opposite page). Install the tie-rods and make the necessary adjustments to align the axles with the frame by turning the tie rod ends. Extra care in making this alignment may save time in the field later. Lower the machine and connect the hydraulic hoses from the cylinder to the hydraulic lines on the frame. With the frame level to the ground, adjust the height of the wheels to obtain approximately 3" from the tip of the #3 rotor flail to the ground. This setting is preliminary and may have to be changed in the field (See Field Adjustments).
2. Attach the tool bar mounting arms to the 6 x 4 strut tube using $\frac{3}{4}$ x $8\frac{1}{2}$ hex bolts and $\frac{3}{4}$ x $6\frac{1}{2}$ eyebolts. See opposite page for spacing. Next, attach the brace brackets to the 6 x 4 strut tube using $\frac{3}{4}$ x $8\frac{1}{2}$ hex bolts and $\frac{3}{4}$ x $6\frac{1}{2}$ eyebolts. (See the Scalper Tool Bar Assembly page in the parts book section of this manual for additional reference.)
3. Slide the tool bar bearing supports onto the scalper tool bars (see opposite page). Lift the tool bar assemblies with a forklift and attach the support bearings to the tool bar mounting arms. A common initial setting for the support bearings is shown in Figure 1. The location will vary depending on the water row depth. **Try to maintain 23"-24" from the top of the beet row to the center of the tool bar.** It's important that the scalper arm has a downward angle from front to rear as shown in Figure 1. Next, attach the lift cylinder arms to the tool bars. Be sure the cylinder arms align with the cylinder ears that are mounted to the rear strut tube (15" wheels), or the cylinder ear on the tool bar support (24" wheels).

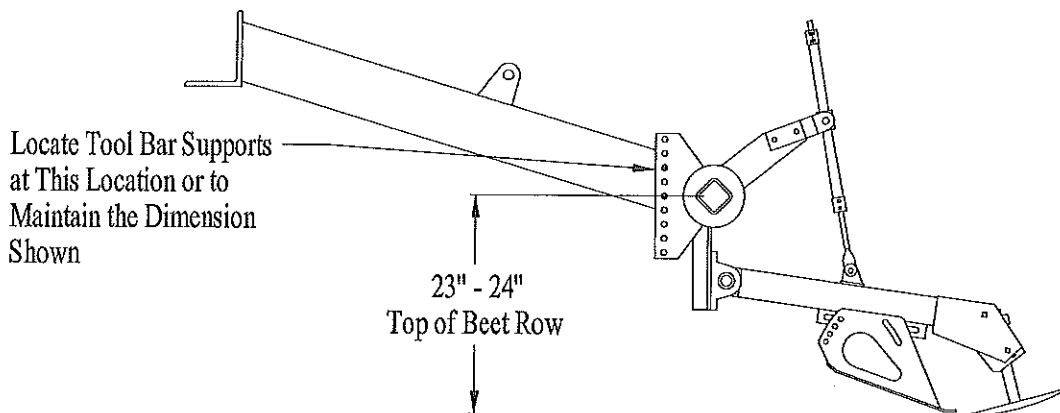
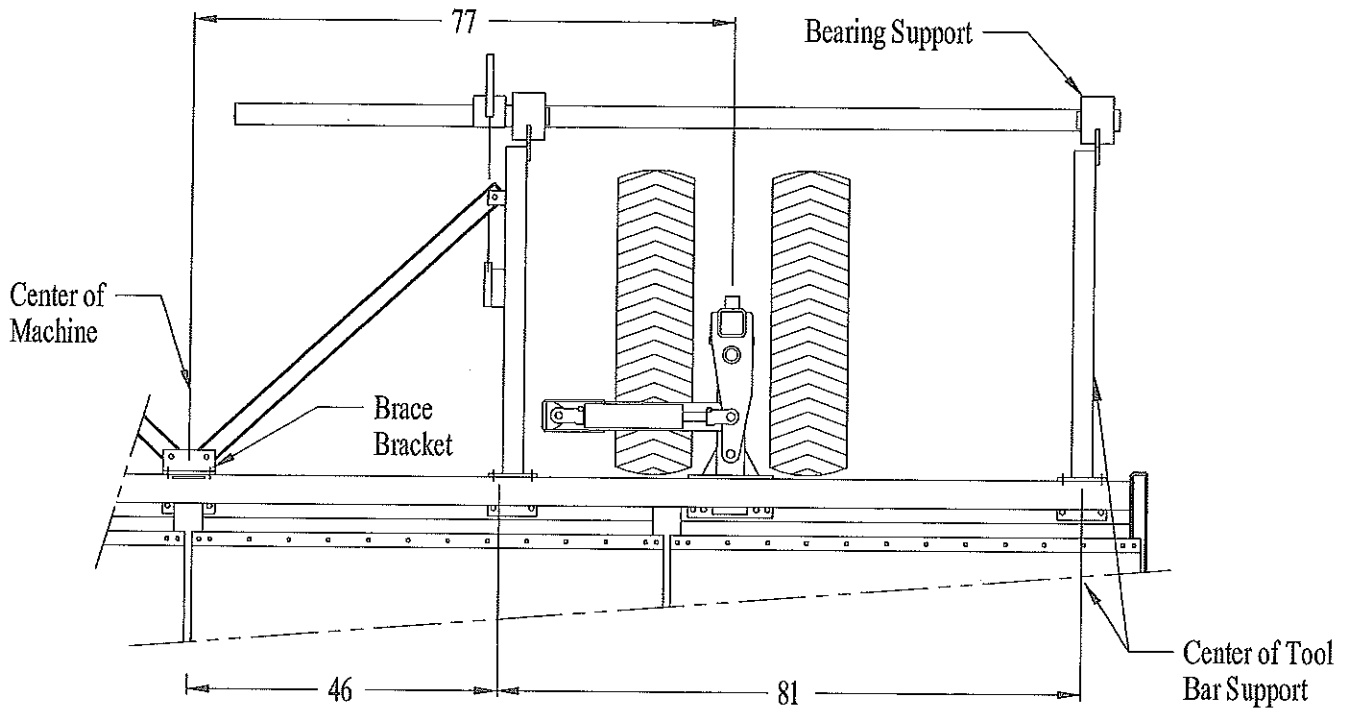
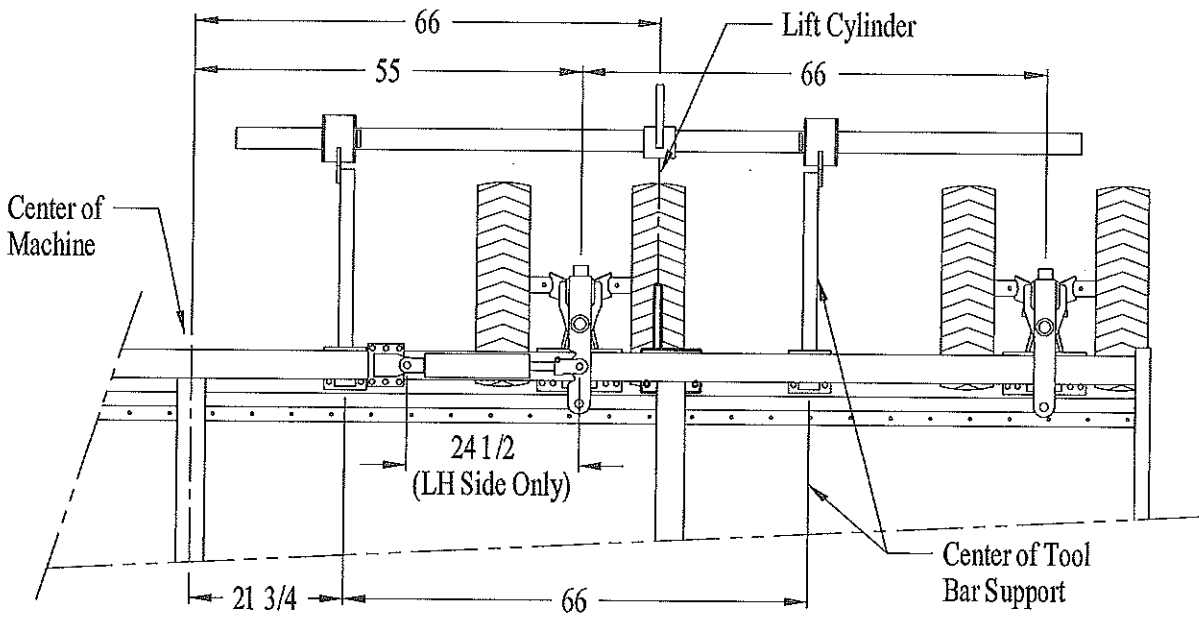

Figure 1.



24" CARRIER WHEELS
LH Side Shown



15" CARRIER WHEELS
LH Side Shown

Setup Procedure Cont....

4. Bolt the scalper head assemblies to the tool bars. Figure 2 shows the correct position (knife scalpers are illustrated). Note the position of the LH & RH knife scalpers.

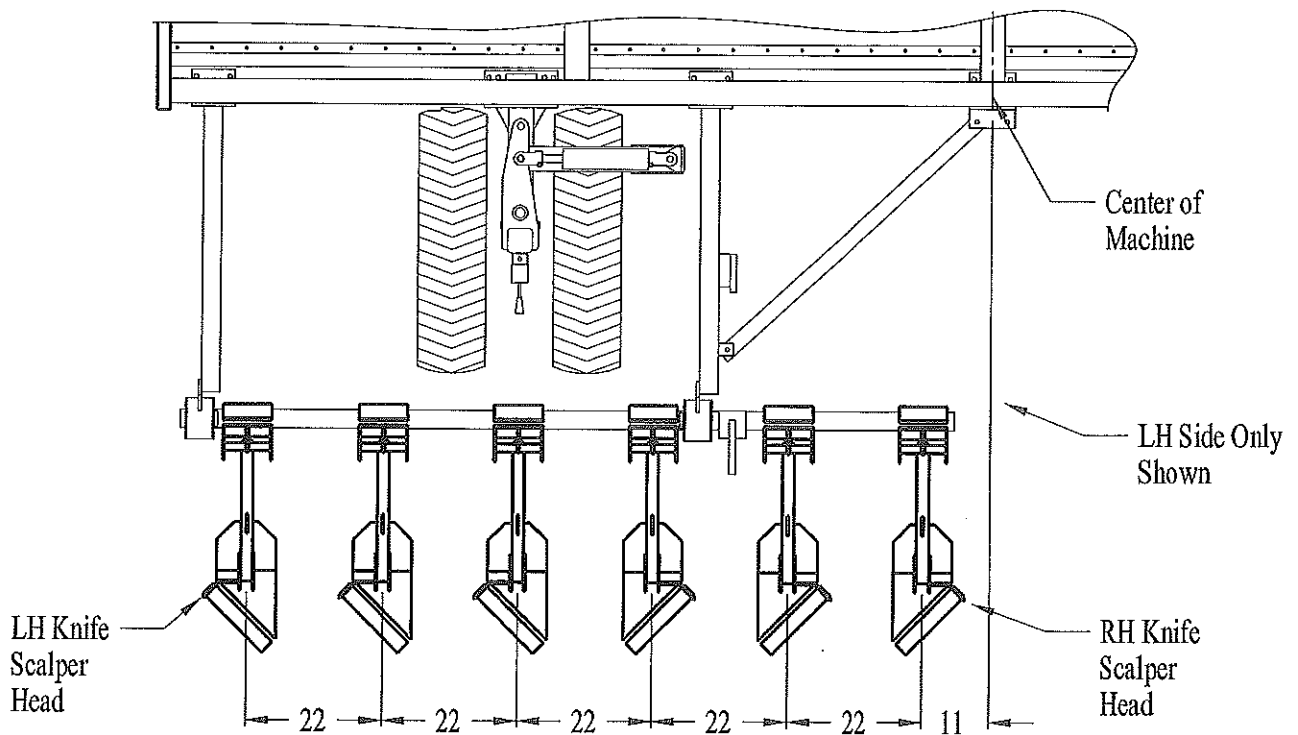

Figure 2.

5. Install the front tongue and pivot pins, as well as the PTO driveline and lift cylinder.

DEALER TEST RUN AND FINAL CHECK

1. Check oil in the gearbox. See the Maintenance and Service section of this manual for the recommended oil
2. Attach defoliator to tractor drawbar using a suitable pin and the tractor hammer strap.
3. Attach PTO to the tractor 1000 RPM PTO shaft
4. Connect hydraulic hoses to the tractor
5. Be sure all persons are clear of machine, and then slowly engage PTO. Check for proper rotation of flails. See Figure 3. Run defoliator for 15-20 minutes and then disengage PTO
6. **With the tractor engine shut off and the ignition key removed**, check the tension of all belts. See Belt Tensioning.
7. Check wheel strut spacing (Page 14.) and check flail spacing for match with row spacing
8. Check to see that all bolts are tight. Refer to the Bolt Torque Page in this manual for recommended tightness. Particular attention should be placed on the flail clamps, scalper mounts, and bearing bolts.



SAFETY... YOU CAN LIVE WITH IT

FIELD ADJUSTMENTS

Flail Height Adjustment

NOTE: Height adjustments are approximate starting points. Final adjustments may differ from those listed below, depending upon field conditions. See Figure 3 for reference.

1. With Scalpers:
 - Adjust the frame height until the rubber flails clear the ground by approximately one inch
 - Adjust front drum height until the steel flails just cut or clear the high beets
2. Without Scalpers:
 - Adjust the frame height until the rubber flails clear the ground by approximately one inch
 - Adjust the front drum height until the steel flails cut off the desired amount of beet crown

NOTE: 1000 RPM on the tractor PTO may not be necessary for proper topping. This may be the case if the beet tops are small. However, in heavy tops or weedy conditions, full 1000 RPM is recommended for the steel flails to cut properly and not "lay back" while spinning.

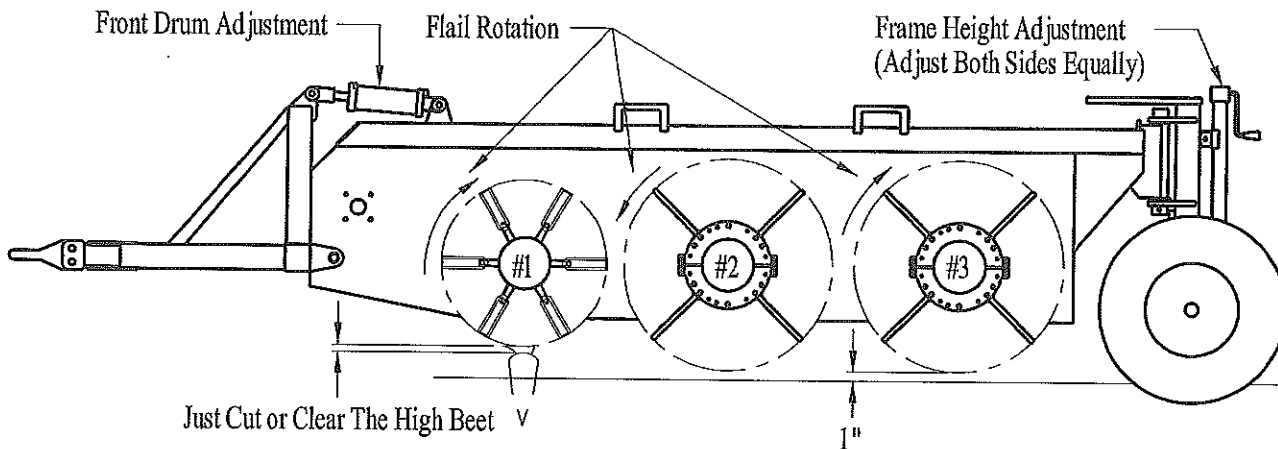

Figure 3.

Scalper Adjustments



AVOID INJURY. Take care when working around scalper knives or disks. They are very sharp.

1. Knife Scalpers (Figure 4):
 - The required adjustments on the disk scalper will vary depending on crop conditions. Make the following adjustments to one scalper head completely, then adjust the remaining heads the same.
 - Adjust the shoe angle so the bottom of the shoe is level when touching the ground. Adjust the knife to the dimensions shown, and straight and level with the shoe. Set the adjusting collar for the down pressure spring so it touches the spring with just a small amount of pressure when the scalper head is touching the top of the row.
 - If this setting needs to be changed, adjust only one scalper until the correct setting is obtained. Then set the other scalpers the same as the first.
 - Now the preliminary adjustments are complete. If these settings need to be changed, adjust only one scalper until the correct setting is obtained. Then set the other scalpers the same as the first. If the angle of cut on the beet is not straight and level, adjust the tilt of the knife. Tilt the knife slightly toward the shoe if the cut on the beet is uphill. Tilt the knife slightly away from the shoe if the cut on the beet is downhill (reset the position of the knife to the shoe).

Scalper Adjustments cont....

- As the knives wear, they can be reversed from the left side to the right side to double the life of the knife.
- If the scalper is bouncing too much and cutting is inconsistent, apply more down pressure by adjusting the spring adjusting collar up a little at a time. If the scalper shoe tends to push beets over, release down pressure by adjusting the spring adjusting collar accordingly.
- Check to be sure the scalper shoes are located over the center of each beet row. Adjust if necessary.

NOTE: The quality of the scalping of the beets is affected greatly by how well the defoliator is cleaning the top of the beet and clearing the row ahead of the scalper unit. Keep the defoliator, as well as the scalper unit, adjusted and maintained and you will experience satisfaction in your topping operation.

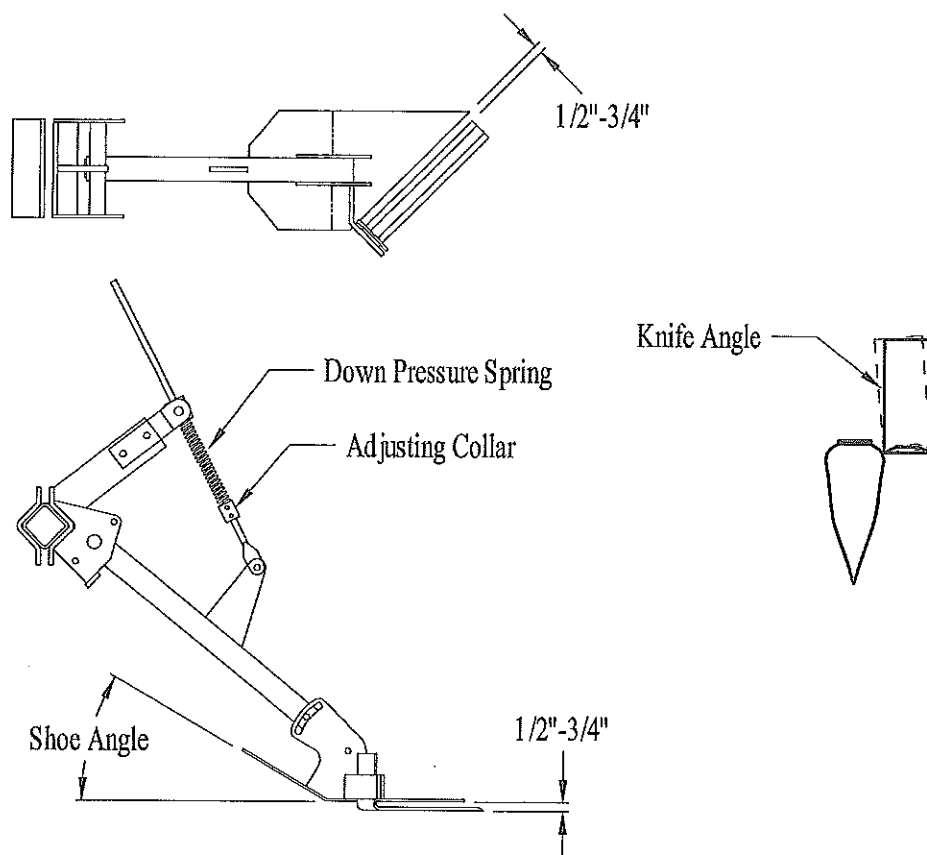

Figure 4.

2. Unpowered Disk Scalper (Figure 5):

- The required adjustments on the disk scalper will vary depending on crop conditions. Make the following adjustments to one scalper head completely, then adjust the remaining heads the same.
- Adjust the shoe angle so the bottom lip of the shoe is level when touching the ground and the bottom of the shoe is approximately 12" from the top of the scalper arm (see Figure 5).
- Adjust the vertical height of the disk to the dimensions shown by loosening the bearing collars on the disk shaft and moving it up or down. Reset the collars when finished.

Scalper Adjustments cont....

- Adjust the horizontal position of the shoe by slightly loosening the shoe mounting bolts, and then tap the shoe with a suitable tool forward or backward to the dimension shown (be sure to maintain the set angle of the shoe).
- Adjust the disk to have a slight angle toward the shoe as illustrated in Figure 5. Remove the top bolt holding the disk assembly and only loosen the bottom bolt. Move the disk to the desired angle, and then reinstall the bolts (tighten securely). **Note: The relationship between the tip of the disk and the shoe will remain the same when the angle of the disk is changed.**
- Set the adjusting collar for the pressure springs so they touch the springs with just a very small amount of pressure when the scalper head is touching the top of the row. The top spring will apply up pressure to the head and the bottom spring will apply down pressure to the head. Adjustments to either or both springs can be made.
- Now the preliminary adjustments are complete. If these settings need to be changed, adjust only one scalper until the correct setting is obtained. Then set the other scalpers the same as the first.
- If the angle of cut on the beet is not straight and level, adjust the tilt of the disk. Tilt the disk slightly toward the shoe if the cut on the beet is uphill. Tilt the disk slightly away from the shoe if the cut on the beet is downhill. **Remember, the relationship between the disk and the shoe will remain the same when the angle of the disk is changed.**
- If the scalper bouncing too much and cutting is inconsistent, apply more down pressure by adjusting the spring adjusting collar up a little at a time. If the scalper shoe tends to push beets over, release down pressure by adjusting the spring adjusting collar accordingly, or adjust the angle of the shoe (reset the horizontal position of the shoe to the disk).
- Check to be sure the scalper shoes are located over the center of each beet row. Adjust if necessary.

NOTE: The quality of the scalping of the beets is affected greatly by how well the defoliator is cleaning the top of the beet and clearing the row ahead of the scalper unit. Keep the defoliator, as well as the scalper unit, adjusted and maintained and you will experience satisfaction in your topping operation.

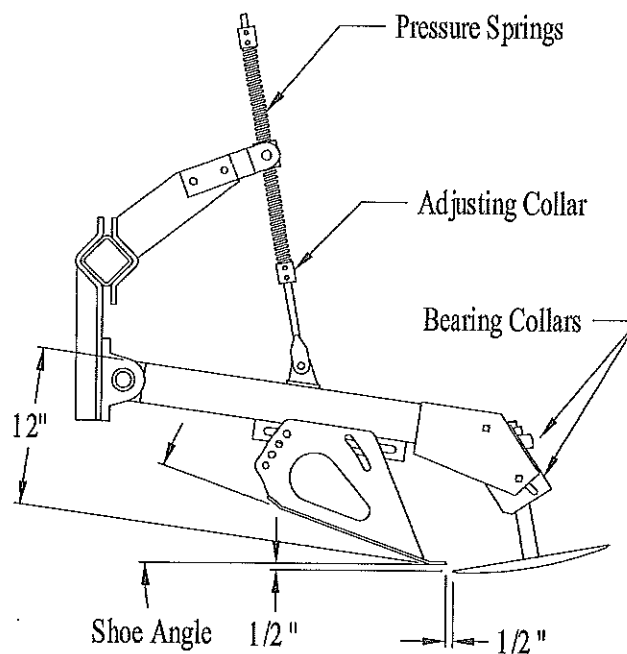

Figure 5.

Scalper Adjustments cont....

3. Hydraulic Driven Disk Scalper (Figure 6):

- The required adjustments on the hydraulic disk scalper will vary depending on crop conditions. Make the following adjustments to one scalper head completely, then adjust the remaining heads the same. **Before any adjustments are made to the Hydraulic Driven Disk Scalper, be sure the tractor engine is shut off and the ignition key is removed.**



AVOID INJURY - SAFETY... YOU CAN LIVE WITH IT

- Adjust the shoe angle so the bottom lip of the shoe is level when touching the ground and the bottom of the shoe is approximately 12" from the top of the scalper arm (see Figure 6). Tighten the shoe mounting bolts to a "snug" position only.
- Now adjust the horizontal and vertical positions of the shoe by tapping the shoe with a suitable tool into position to the dimension shown.
- Adjust the disk to have a slight angle toward the shoe as illustrated in Figure 6. Remove the top bolt holding the disk assembly and only loosen the bottom bolt. Move the disk to the desired angle, and then reinstall the bolts (tighten securely). **Note: The relationship between the tip of the disk and the shoe will remain the same when the angle of the disk is changed.**
- Set the adjusting collar for the bottom pressure spring so it touches the spring with just a very small amount of pressure when the scalper head is touching the top of the row, and then adjust the collar for the top pressure spring so it is compressed approximately 1 1/2".
- Now the preliminary adjustments are complete. If these settings need to be changed, adjust only one scalper until the correct setting is obtained. Then set the other scalpers the same as the first.
- If the angle of cut on the beet is not straight and level, adjust the tilt of the disk. Tilt the disk slightly toward the shoe if the cut on the beet is uphill. Tilt the disk slightly away from the shoe if the cut on the beet is downhill. **Remember, the relationship between the disk and the shoe will remain the same when the angle of the disk is changed.**
- If the scalper is bouncing too much and cutting is inconsistent, apply more down pressure by moving the adjusting collar the bottom up a little at a time. If the scalper tends to push over beets, reduce the down pressure and increase the up pressure on the springs accordingly, or adjust the angle of the shoe (reset the position of the shoe to the disk).
- Check to be sure the scalper shoes are located over the center of each beet row. Adjust if necessary.

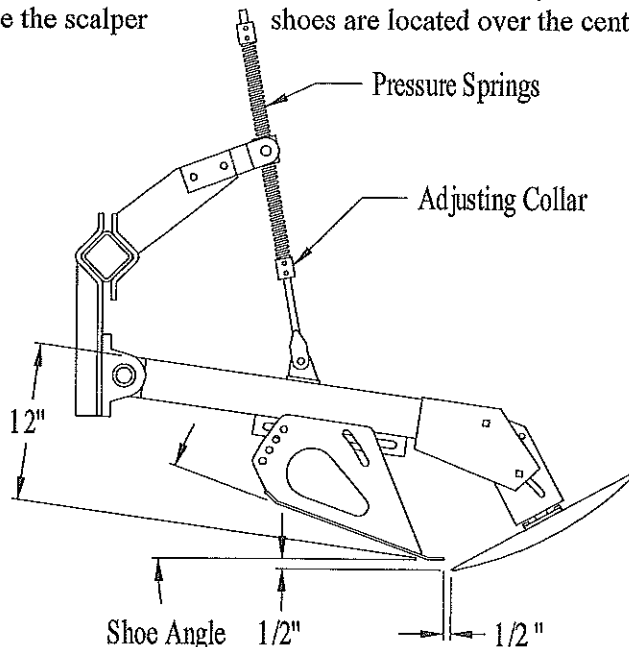

Figure 6.



SAFETY... YOU CAN LIVE WITH IT

Belt Tensioning

Check belt tensions often. Adjust the tension springs on all the rotor drives to the approximate dimension shown in Figure 7. This will give the proper tension on the drive belts. A good rule of thumb is adjust the tension so that a quarter or nickel just passes through the coils of the spring. **DO NOT ADJUST THE TENSION SO THAT THE SPRING COILS ARE TIGHT TOGETHER.** This will permanently damage the spring and the spring force will be limited.

IMPORTANT!

The drive belts on this unit must be re-tensioned **after the first half hour of operation** or they may slip and be damaged. If the belts heat up after the proper adjustments have been made, then the ground speed is too fast or the defoliator is too low to the ground.

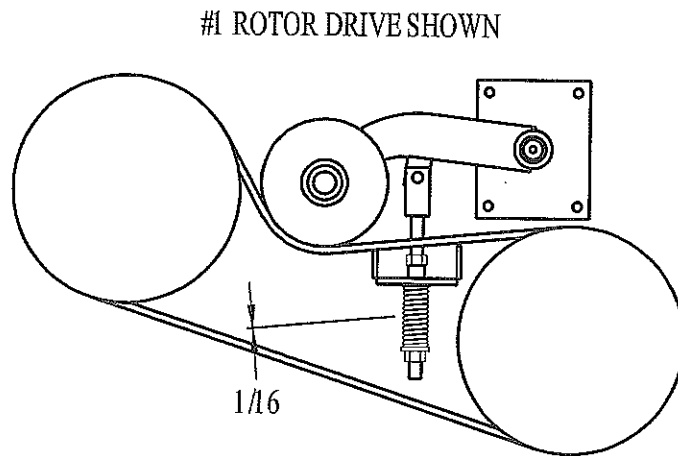

Figure 7.

PARMA[®]

**Model 264 Series
Beet Defoliator
PARTS CATALOG**

Manual Number 01292013-DEFOL

PARMA COMPANY

P.O. BOX 190
PARMA, IDAHO 83660
PHONE (208) 722-5116 FAX (208) 722-6012
website: www.parmacompany.com

TABLE OF CONTENTS

ELECTRIC SWITCH BOX.....	39
FLAIL CLUSTER ASSEMBLIES (#2 & #3 Rotors)	21
FRONT GAUGE WHEEL ASSEMBLY	38
GEAR BOX ASSEMBLY	8
GROUND DRIVEN DISK ASSEMBLY.....	33
HYDRAULIC DRIVEN DISK ASSEMBLY	34
HYDRAULIC DISK SCALPER HYDRAULICS	36
KNIFE SCALPER HEAD ASSEMBLY.....	31
MAIN DRIVE PARTS	6
OUTER FRAME PARTS	4
PTO DRIVELINE ASSEMBLY, CONSTANT VELOCITY.....	2
PTO DRIVELINE ASSEMBLY, STANDARD.....	1
REAR NON-STEERABLE WHEELS – 15”	22
REAR STEERABLE WHEELS – 15”	24
REAR STEERABLE WHEELS – 24”	26
REAR NON-STEERABLE WHEELS – 24”	27
ROTOR ASSEMBLY #1, CUP KNIFE (Welded Rotor Shafts).....	10
ROTOR ASSEMBLY #1, L-KNIFE (Welded Rotor Shafts).....	12
ROTOR ASSEMBLY #2 (Welded Rotor Shafts)	14
ROTOR ASSEMBLY #3 (Welded Rotor Shafts)	16
ROTOR PARTS #1 (For Replaceable Shafts).....	18
ROTOR PARTS #2 & #3 (For Replaceable Shafts).....	20
SCALPER TOOL BAR ASSEMBLY (15” Rear Carrier Wheels)	29
SCALPER TOOL BAR ASSEMBLY (24” Rear Carrier Wheels)	30
SCALPER ARM ASSEMBLY (Ground Driven & Hydraulic Driven Scalpers).....	32
TWO WAY STEERING.....	28

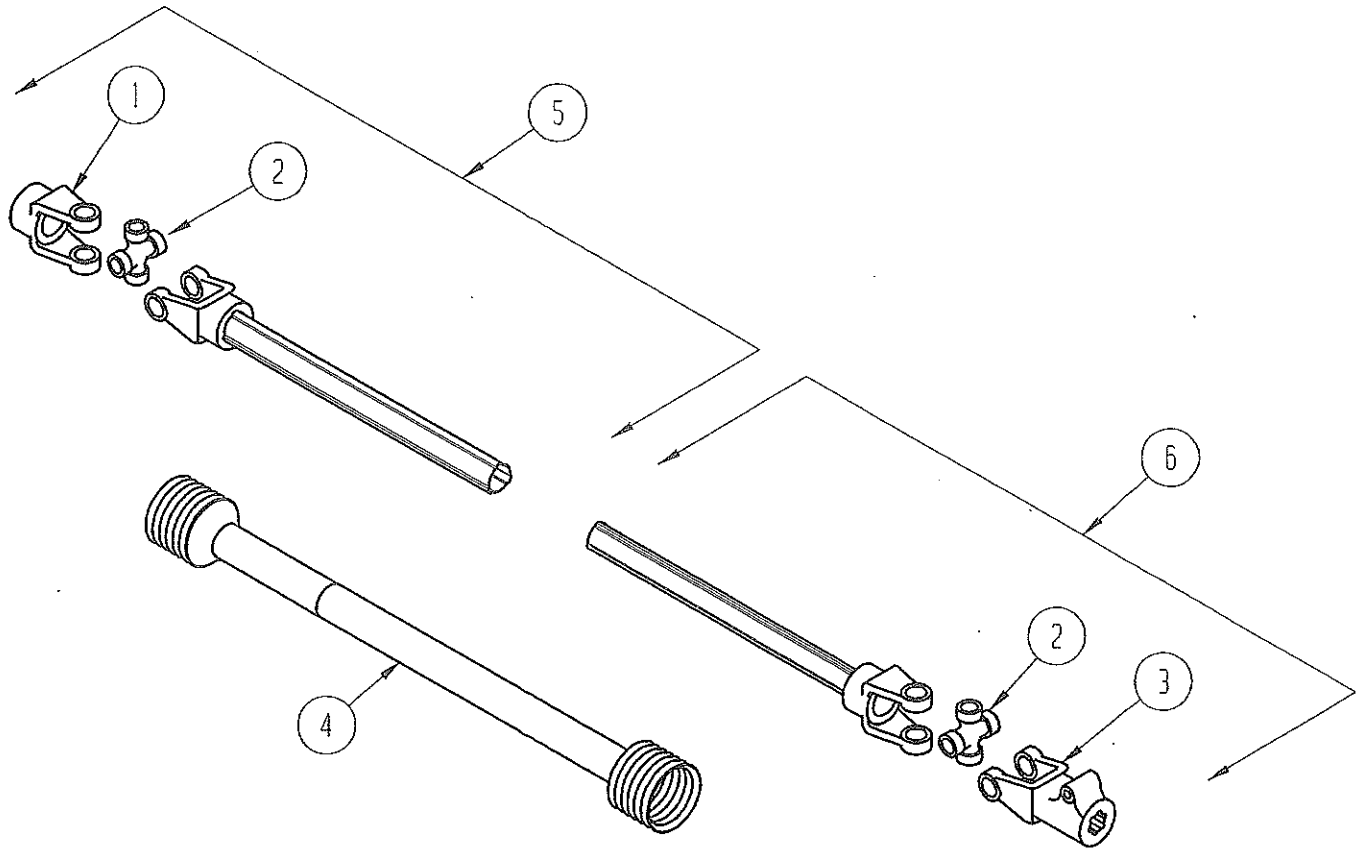

DRIVELINE ASSEMBLY. STANDARD
 #281397 (1 3/4-20")

ITEM NO.	QUANTITY	PART NO.	DESCRIPTION
1	1	991039	Yoke, 1 1/4 Round Bore
2	2	991009	Cross & Bearing Kit
3	1	991013	Yoke, 1 1/4-20 Splined, QD
4	1	991082	Shield Assembly
5	1	281583	Driveline Implement Half w/ Shield
6	1	281582	Driveline Tractor Half w/ Shield

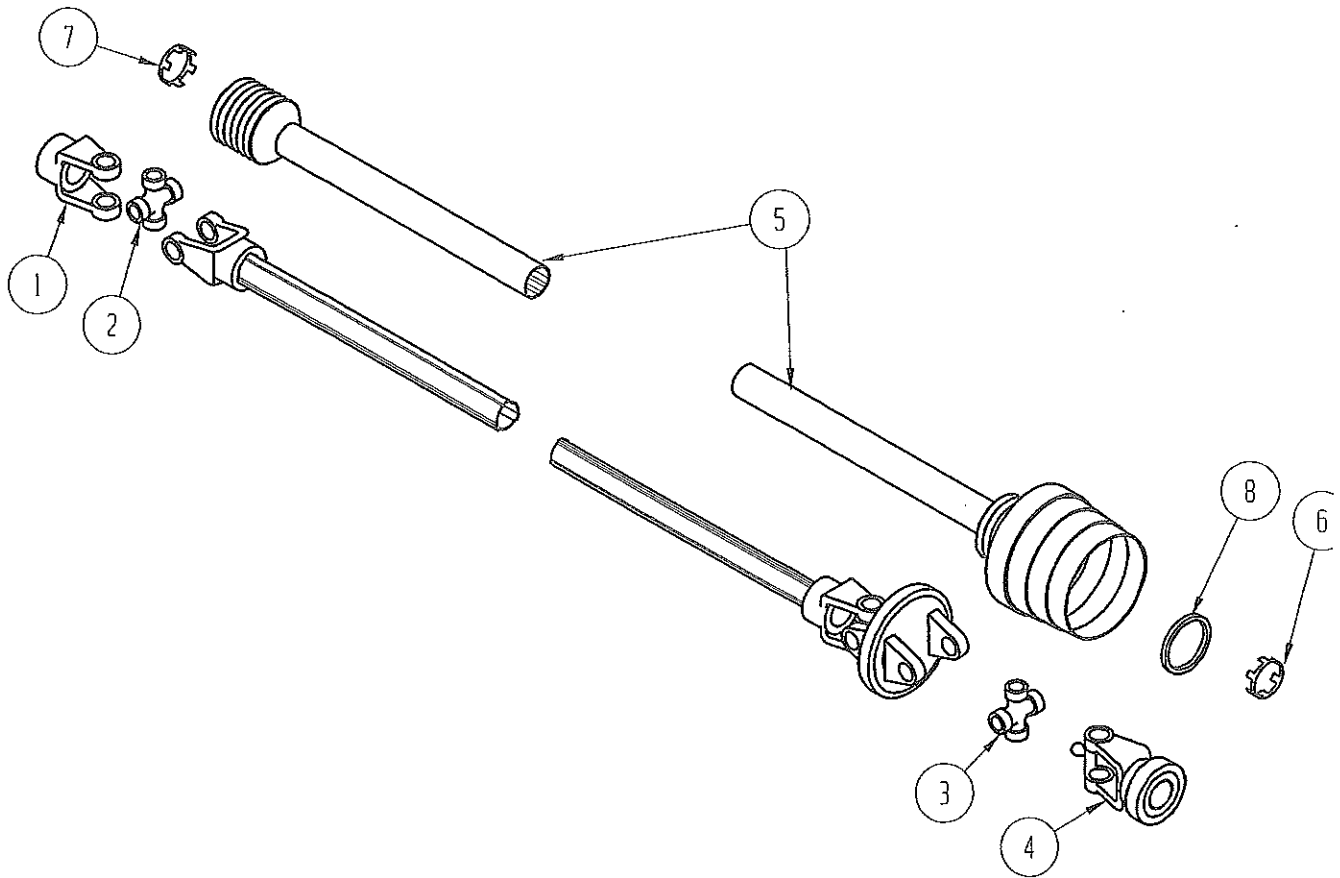

CONSTANT VELOCITY DRIVELINE ASSEMBLY
 #282510 (1 3/4-20 Spline)

ITEM NO.	QUANTITY	PART NO.	DESCRIPTION
1	1	991098	Yoke, 1 3/4 Round Bore
2	1	991101	Cross & Bearing Kit (Implement End)
3	1	991100	Cross & Bearing Kit (Tractor End)
4	1	991107	Yoke, 1 3/4-20 Splined, QD
	1	991102	Yoke, 1 3/8-21 Splined, QD
5	1	991103	Shield Assembly
6	1	991104	Bearing Retainer, Outer Shield
7	1	991105	Bearing Retainer, Inner Shield
8	1	991106	CV Cone Retainer

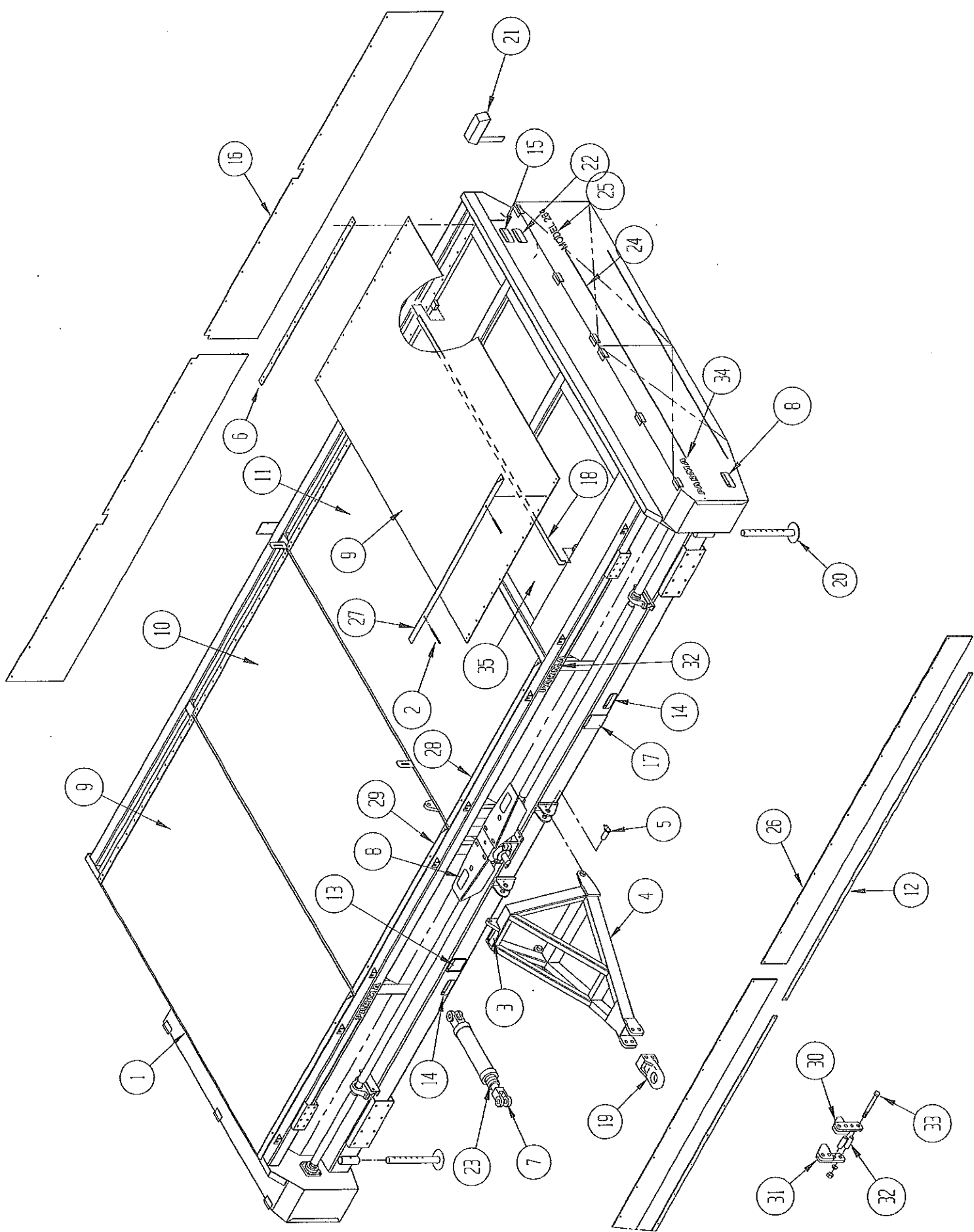

OUTER FRAME PARTS

ITEM NO.	QUANTITY	PART NO.	DESCRIPTION
1	1	282167	Main Frame
2	8	-----	Treaded Rod, 1/2" x 6"
3	1	100405	Decal, Operation
4	1	281435	Tongue
5	2	282217	Tongue Pin
6	4	281571	Belt Strap
7	1	282206	Hydraulic Cylinder, 3 1/2 x 10
8	4	100409	Decal, Keep Guards in Place
9	2	281540	Vinyl Cover, Outside
10	1	282342	Vinyl Cover, LH Center
11	1	282343	Vinyl Cover, RH Center
12	2	281543	Back-Up Bar
13	1	100311	Decal, Rotating Parts
14	2	100404	Decal, Block Machine
15	2	100564	Decal, Caution
16	1	281545	Rear Belt Flap
17	1	100406	Decal, Caution
18	4	282174	Support Bar
19	1	521104	Ring Hitch, Cat III
20	2	230211	Jack Stand
21	1	281890	Warning Light Kit
22	2	100565	Decal, Caution
23	1	522012	Stroke Control Kit
24	As Req'd	264798	Double Stripe Tape
25	2	282003	Decal, Model 264
26	1	281544	Front Belt Flap
27	2	282173	Belting Angle, Outside
28	1	282340	Belting Angle, LH Center
29	1	282341	Belting Angle, RH Center
30	1	281996	Hitch Extension, LH (Optional)
31	1	281997	Hitch Extension, RH (Optional)
32	2	281998	Spacer (Optional)
33	4	-----	Hex Bolt, 1 x 9 Grade 5 (Optional)
34	4	264797	Decal, Parma
35	2	282469	UHMW Material Shield

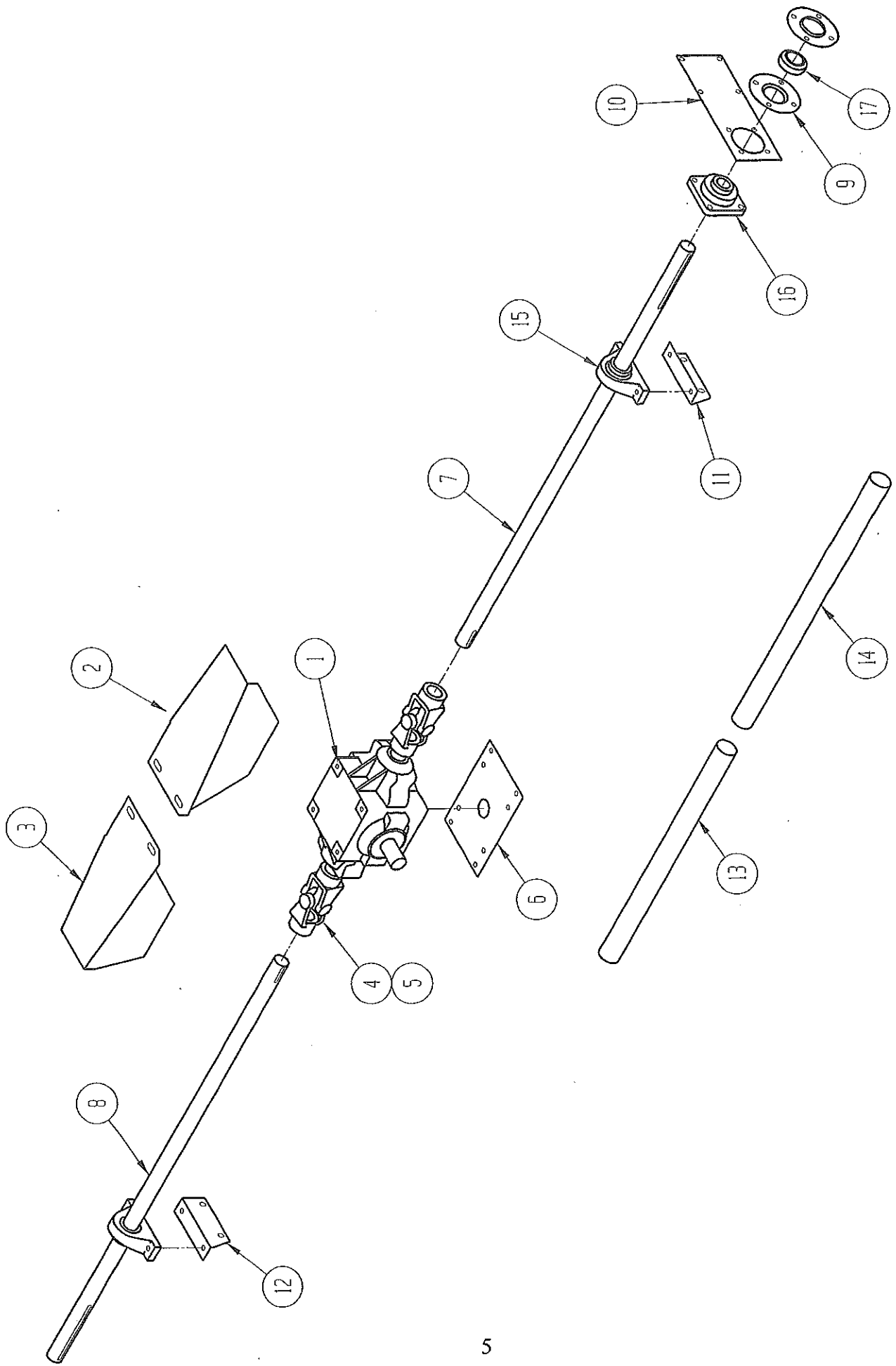

MAIN DRIVE PARTS

ITEM NO.	QUANTITY	PART NO.	DESCRIPTION
1	1	999171	Gear Box, 1:1 Ratio
2	1	230077	Gear Box Cover, LH
3	1	230078	Gear Box Cover, RH
4	4	267976	Yoke, 35N 1 3/4 Bore
5	2	990653	Cross & Bearing Kit
6	1	281474	Gear Box Mount Plate
7	1	282097	Cross Drive Shaft, LH
8	1	282098	Cross Drive Shaft, RH
9	2	290035	Flangette Pair 85 MM
10	2	281499	Bearing Mounting Plate
11	1	281445	Bearing Mount, LH
12	1	281444	Bearing Mount, RH
13	2	281987	Shaft Cover, Long
14	2	281986	Shaft Cover, Short
15	2	980028	Bearing, 1 3/4 Pillow Block
16	2	980033	Bearing, 1 3/4 4 Hole Flanged
		980165	Bearing Insert, 1 3/4 (For Above)
17	2	980104	Bearing, 1 3/4

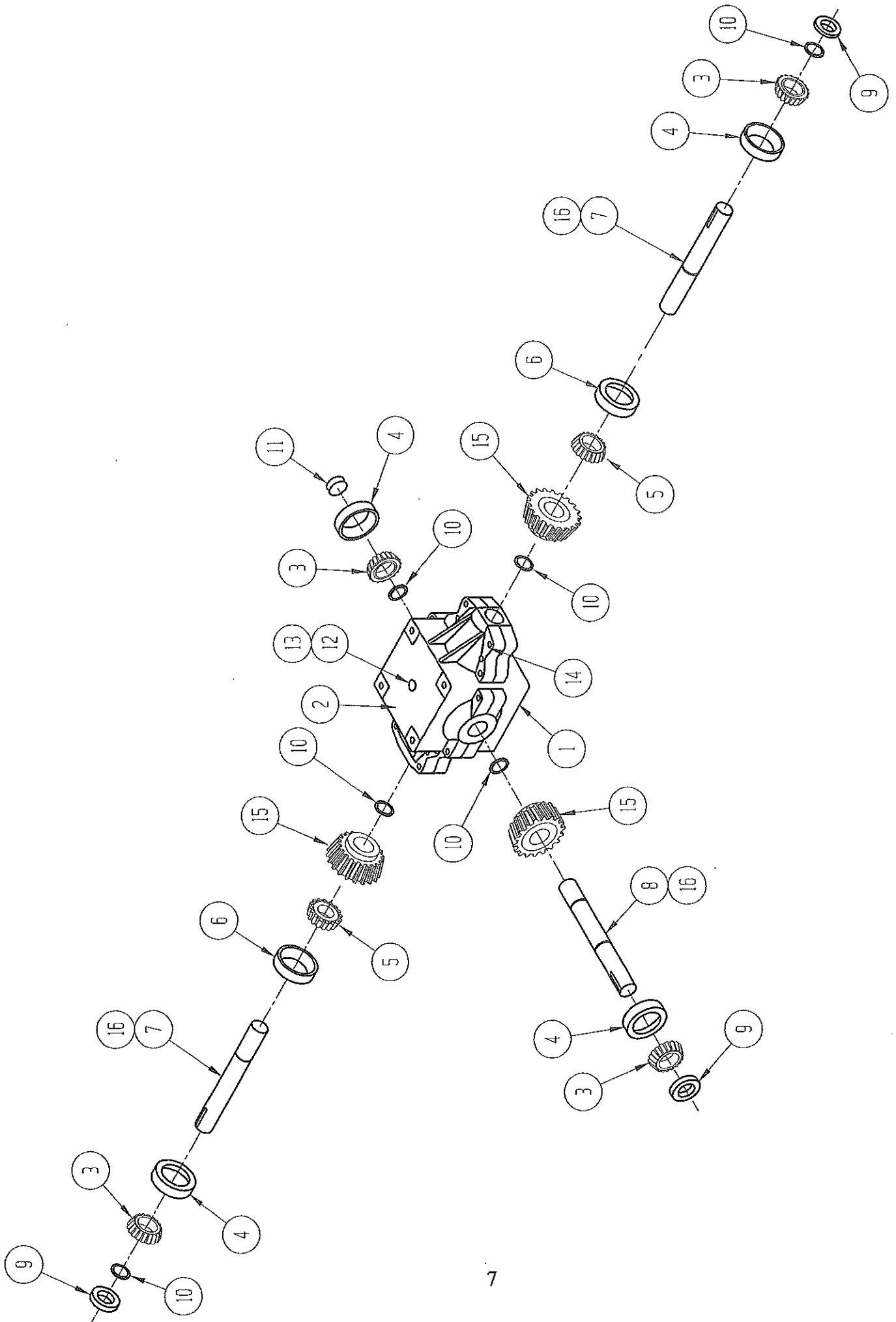

GEAR BOX ASSEMBLY
 (#999171)

ITEM NO.	QUANTITY	PART NO.	DESCRIPTION
1	1	999461	Gear Box Housing (Threaded Holes)
2	1	999463	Gear Box Housing (Thru Holes)
3	4	990947	Bearing Cone
4	4	990001	Bearing Cup
5	2	990946	Bearing Cone
6	2	990025	Bearing Cup
7	2	999462	Pinion Shaft
8	1	999465	Cross Shaft
9	3	999470	Seal
10	6	999518	Retaining Ring
11	2	999464	Shaft End Plug
12	1	999117	Pressure Relief Vent
13	1	290644	Pipe Bushing
14	16	-----	Socket Head Cap Screw, 3/8-16 x 2 1/4
15	3	999460	Gear
16	3	999519	Key

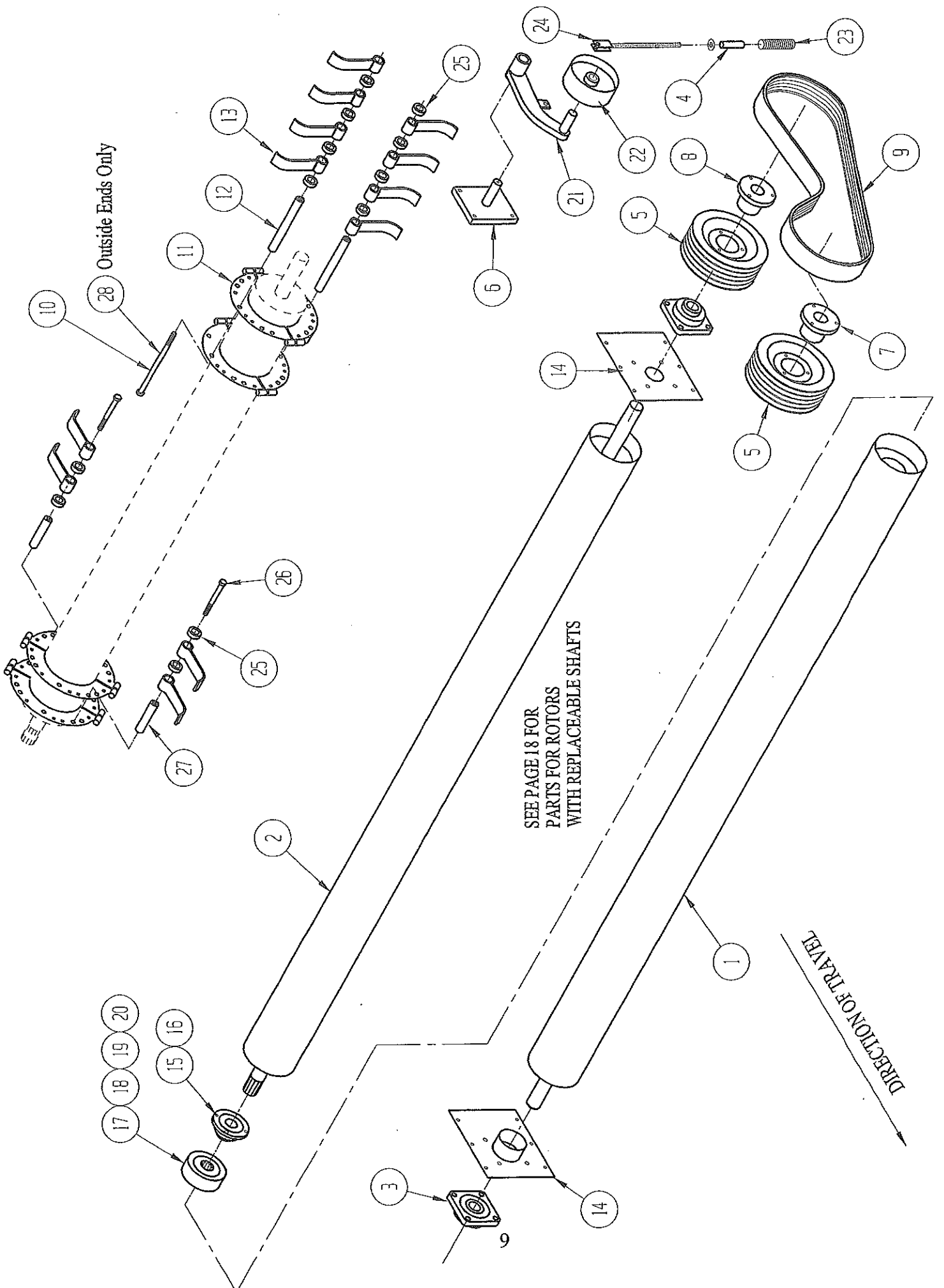

ROTOR ASSEMBLY #1, CUP- KNIFE
(Welded Rotor Shafts)

ITEM NO.	QUANTITY	PART NO.	DESCRIPTION
1	1	281743	#1 Rotor Weldment, Driven End
2	1	281738	#1 Rotor Weldment, Drive End
3	2	980034	Bearing, 2 3/16 4 Hole Flanged
		980153	Bearing Insert, 2 3/16 (For Above)
4	1	281604	Spring Tube
5	2	982355	Sheave, 5-5V 14.0"
6	1	282144	Idler Bracket
7	1	980384	Bushing, E-1 3/4
8	1	980391	Bushing, E-2 3/16
9	1	282094	Power Band Belt, 5-5VX-1060
10	40	281786	Hex Bolt, 5/8 X 13 Grd-5
11	52	281722	Half Clamp
12	44	281785	Hardened Bushing
13	184	282199	Steel Cup Flail, 5/16
14	2	281908	Bearing Plate
15	1	281563	Bearing Housing
16	1	281975	Bearing Insert, 1 15/16 (No Substitute Please)
17	1	281829	Coupler
18	1	281828	Snap Ring
19	6	490024	Socket Head Cap Screw, 3/8 x 3
20	1	281575	O-Ring
21	1	282147	Idler arm
22	1	282500	Idler Pulley Assembly
	-	-----	-----
23	1	264636	Spring
24	1	282091	Take-up Bolt
25	184	282083	Spacer
26	4	282085	Hex Bolt, 5/8 x 7 1/2 Grd-5
27	4	282084	Hardened Bushing
28	4	282086	Hex Bolt, 5/8 x 12 1/4 Grd-5

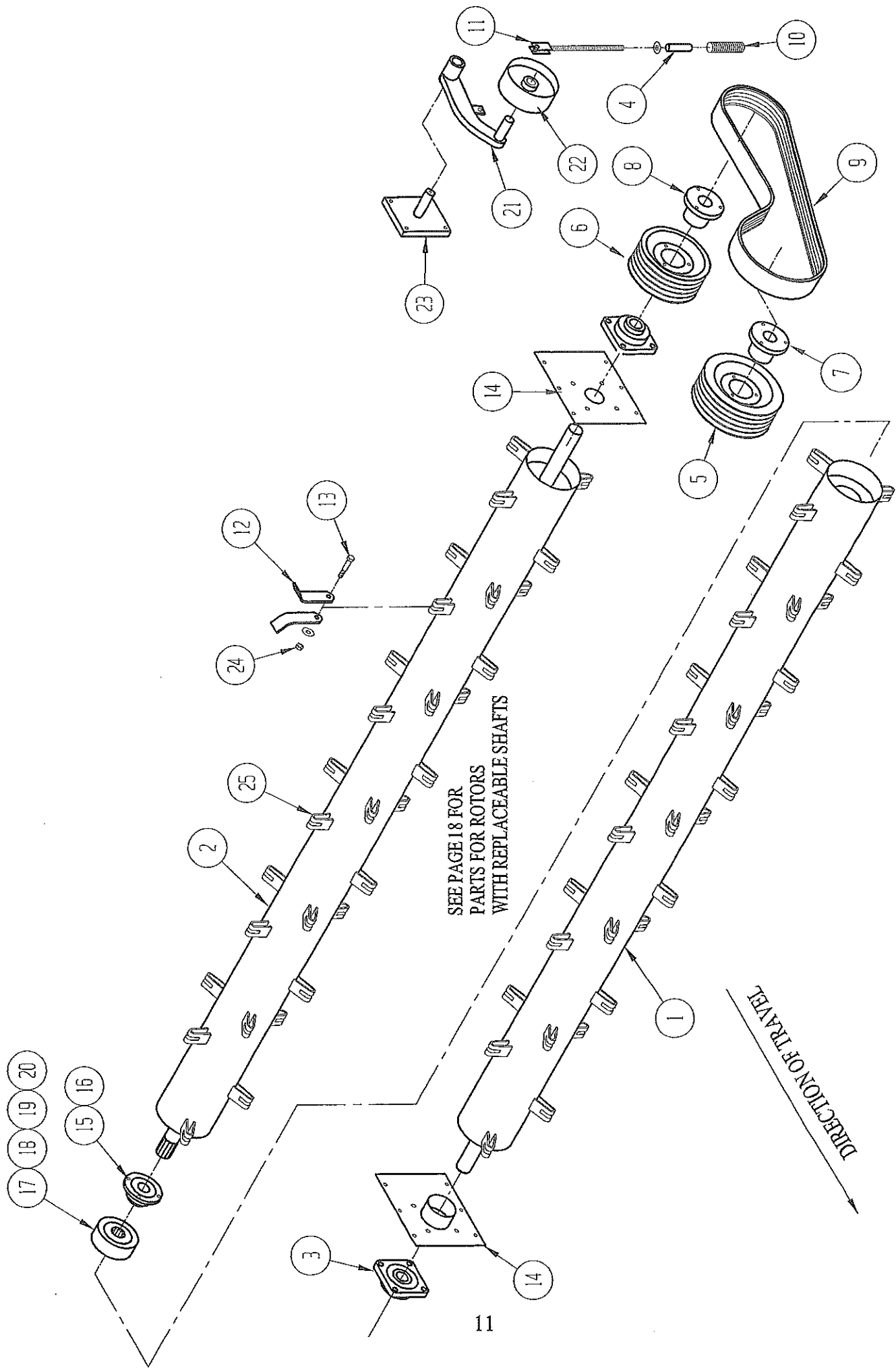

ROTOR ASSEMBLY #1, "L" KNIFE
(Welded Rotor Shafts)

ITEM NO.	QUANTITY	PART NO.	DESCRIPTION
1	1	281859	#1 Rotor Weldment, Driven End
2	1	281860	#1 Rotor Weldment, Drive End
3	2	980034	Bearing, 2 3/16 4 Hole Flanged
		980153	Bearing Insert, 2 3/16 (For Above)
4	1	281604	Spring Tube
5	1	982355	Sheave, 5-5V 14.0"
6	1	282193	Sheave, 5-5V 10.9"
7	1	980384	Bushing, E-1 3/4
8	1	980391	Bushing, E-2 3/16
9	1	281821	Power Band Belt, 5-5VX-1000
10	1	264636	Spring
11	1	282091	Draw Bolt
12	144	281569	L-Knife
13	72	-----	Hex Cap Screw, 5/8 x 3 1/2 Grd-8
14	2	281908	Bearing Plate
15	1	281563	Bearing Housing
16	1	281975	Bearing Insert, 1 15/16 (No Substitute Please)
17	1	281829	Coupler
18	1	281828	Snap Ring
19	6	490024	Socket Head Cap Screw, 3/8 x 3
20	1	281575	O-Ring
21	1	282147	Idler Arm
22	1	282500	Idler Pulley Assembly
	-	-----	-----
23	1	282144	Idler Bracket
24	72	-----	Lock Nut, 5/8
25	72	281871	Flail Clip

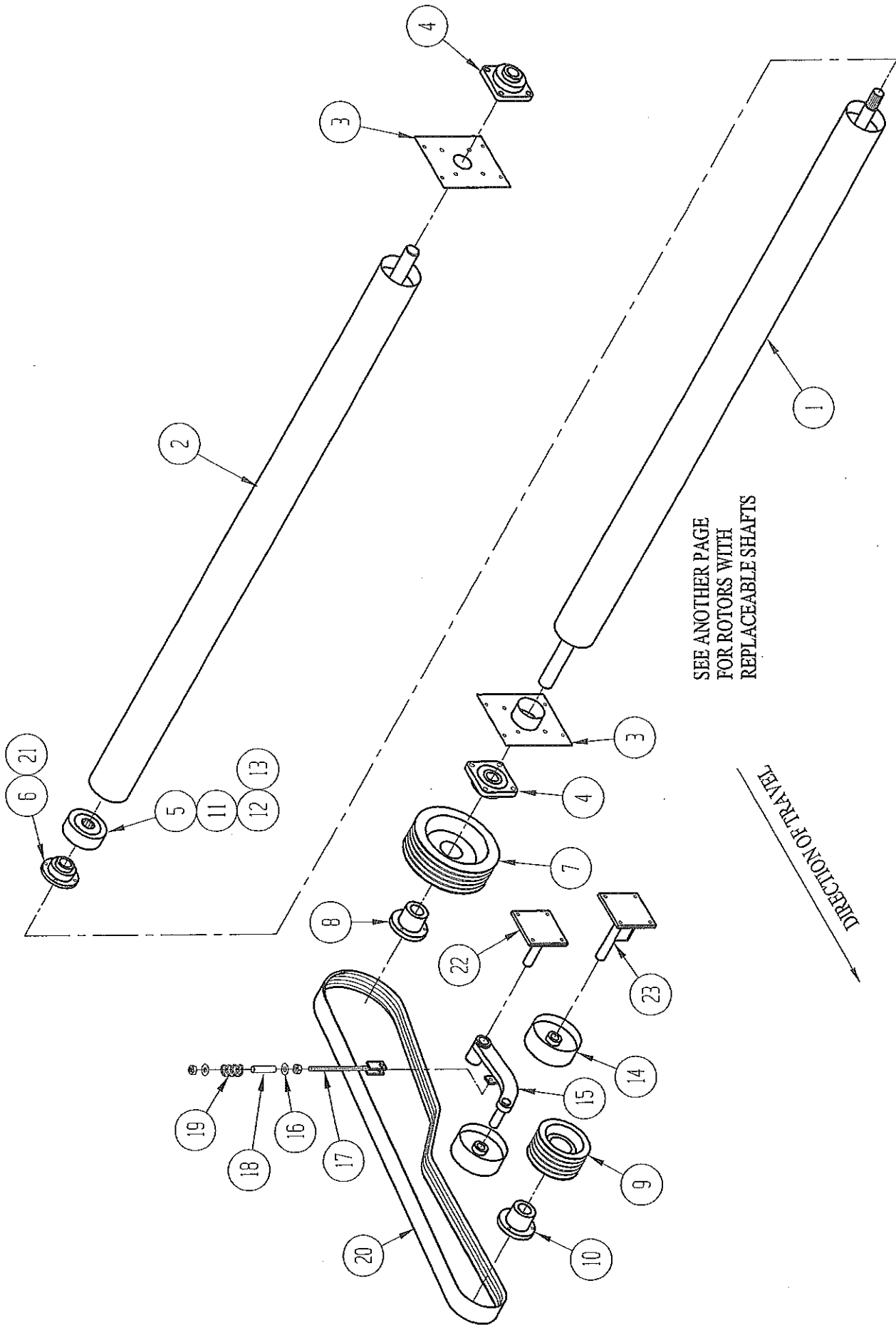

SEE ANOTHER PAGE
FOR ROTORS WITH
REPLACEABLE SHAFTS

DIRECTION OF TRAVEL

ROTOR ASSEMBLY #2
(Welded Rotor Shafts)

ITEM NO.	QUANTITY	PART NO.	DESCRIPTION
1	1	281492	#2 Rotor, Drive End
2	1	281480	#2 & #3 Rotor, Driven End
3	2	281909	Bearing Plate
4	2	980034	Bearing, 4 Hole Flanged
		980153	Bearing Insert, 2 3/16 (For Above)
5	1	281568	Coupler
6	1	281563	Bearing Housing
7	1	282096	Sheave, 5-5V-16.0"
8	1	980391	Bushing, E-2 3/16
9	1	980873	Sheave, 5-5V-8.0"
10	1	980384	Bushing, E-1 3/4
11	1	281828	Snap Ring
12	6	490024	Socket Head Cap Screw, 3/8 x 3
13	1	281575	O-Ring
14	2	282500	Idler Pulley Assembly
	-	-----	-----
15	1	282147	Idler Arm
16	1	-----	Flat Washer, 3/4 SAE
17	1	282091	Draw Bolt
18	1	281604	Spring Tube
19	1	264636	Spring
20	1	282095	Power Band Belt, 5-5VX-1700
21	1	281975	Bearing Insert, 1 15/16 (No Substitute Please)
22	1	282158	Idler Arm Bracket
23	1	282152	Idler Bracket

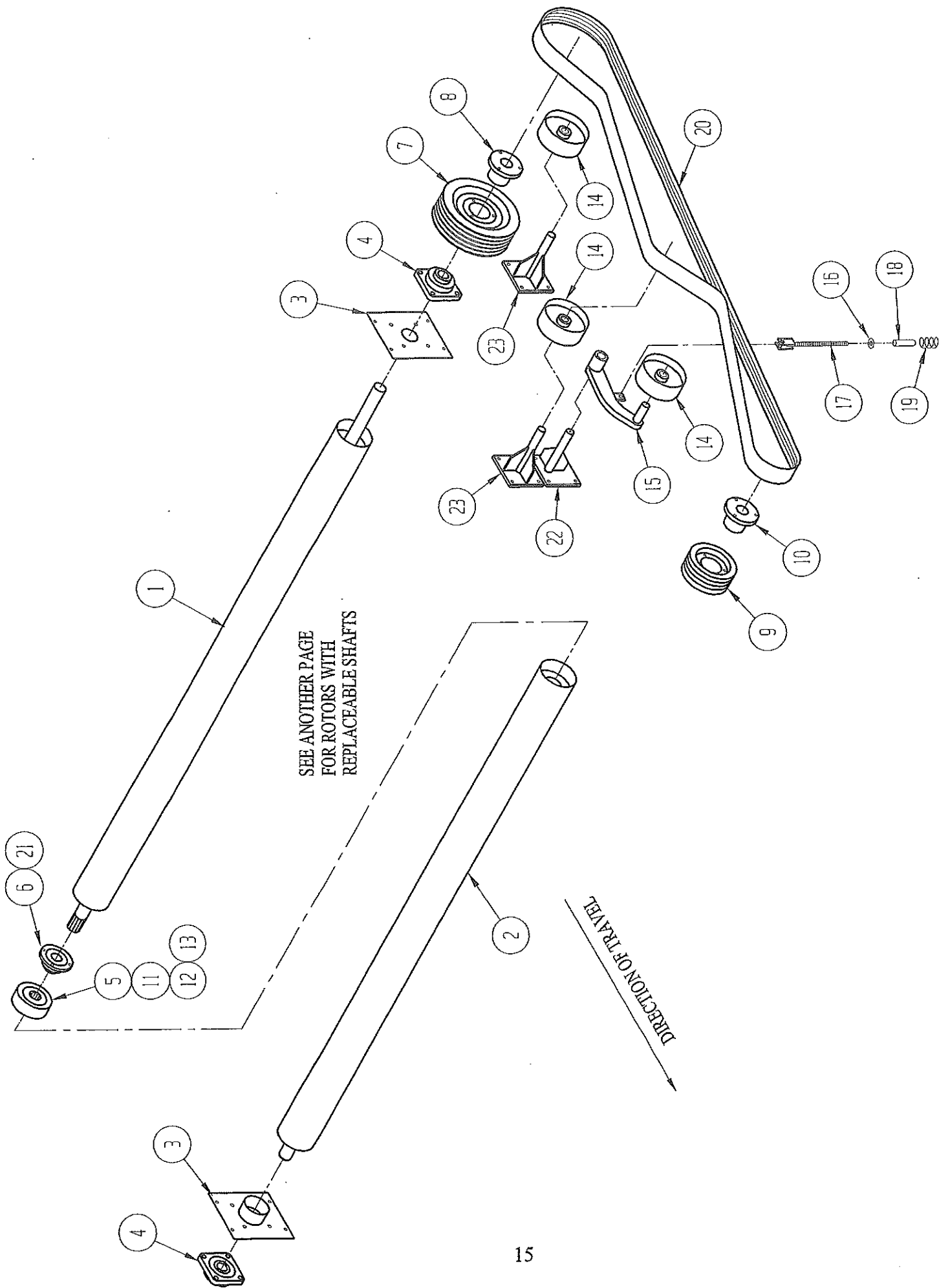

ROTOR ASSEMBLY #3
(Welded Rotor Shafts)

ITEM NO.	QUANTITY	PART NO.	DESCRIPTION
1	1	281488	#3 Rotor, Drive End
2	1	281480	#2 & #3 Rotor, Driven End
3	2	281909	Bearing Plate
4	2	980034	Bearing, 4 Hole Flanged
		980153	Bearing Insert, 2 3/16 (For Above)
5	1	281568	Coupler
6	1	281563	Bearing Housing
7	1	282096	Sheave, 5-5V-16.0"
8	1	980391	Bushing, E-2 3/16
9	1	980873	Sheave, 5-5V-8.0"
10	1	980384	Bushing, E-1 3/4
11	1	281828	Snap Ring
12	6	490024	Socket Head Cap Screw, 3/8 x 3
13	1	281575	O-Ring
14	3	282500	Idler Pulley Assembly
	-	-----	-----
15	1	282147	Idler Arm
16	1	-----	Flat Washer, 3/4 SAE
17	1	282091	Draw Bolt
18	1	281604	Spring Tube
19	1	264636	Spring
20	1	281993	Power Band Belt, 5-5VX-2500
21	1	281975	Bearing Insert, 1 15/16 (No Substitute Please)
22	1	282155	Idler Arm Bracket
23	2	282152	Idler Bracket

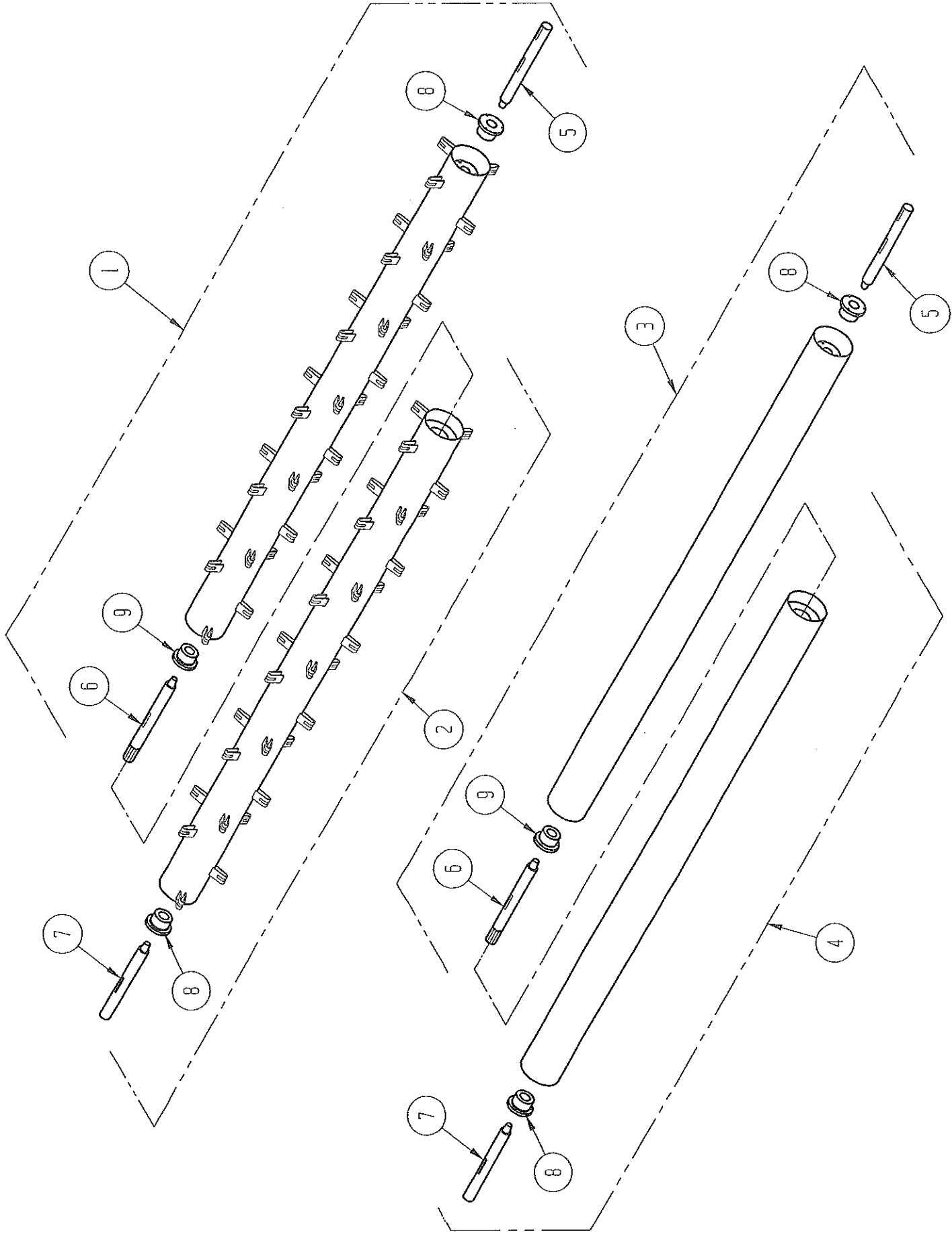

ROTOR PARTS #1
(For Replaceable Shafts)

ITEM NO.	QUANTITY	PART NO.	DESCRIPTION
1	1	282197	#1 Rotor Asm, L-Knife, Drive End
2	1	282198	#1 Rotor Asm, L-Knife, Driven End
3	1	282050	#1 Rotor Asm, Cup Knife, Drive End
4	1	282065	#1 Rotor Asm, Cup Knife, Driven End
5	1	282054	Tapered Shaft, Drive End
6	1	282056	Tapered Shaft, Splined
7	1	282067	Tapered Shaft, Driven End
8	2	282058	Bushing, R1-2 3/16 Split Tapered
9	1	980219	Bushing, Q1-1 15/16 Split Tapered

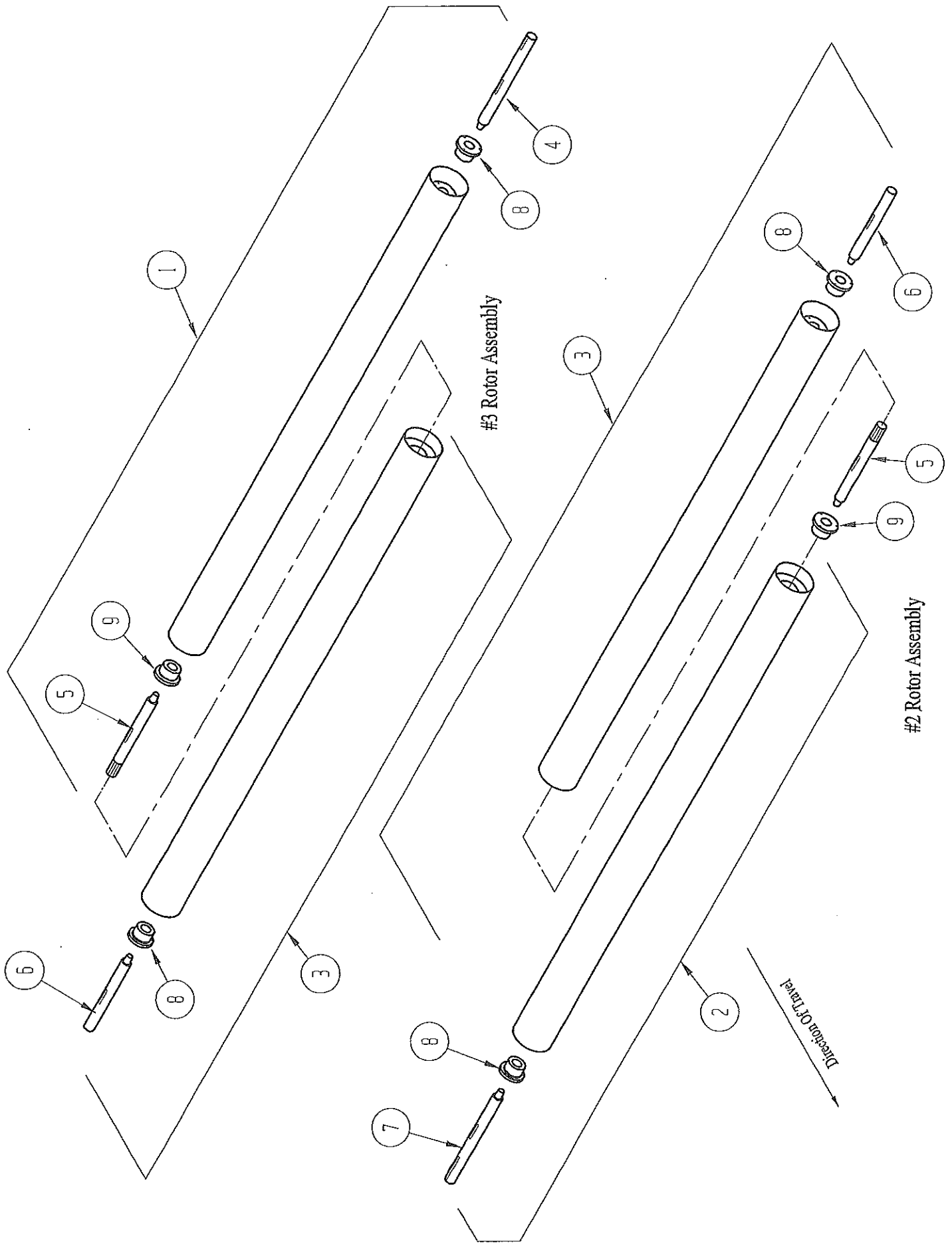

ROTOR PARTS #2 & #3
(For Replaceable Shafts)

ITEM NO.	QUANTITY	PART NO.	DESCRIPTION
1	1	282079	#3 Rotor Asm, Drive End
2	1	282068	#2 Rotor Asm, Drive End
3	2	282080	#2 & #3 Rotor Asm, Driven End
4	1	282078	Tapered Shaft, #3 Rotor Drive End
5	2	282056	Tapered Shaft, Splined
6	2	282067	Tapered Shaft, #2 & #3 Rotor Driven End
7	1	282072	Tapered Shaft, #2 Rotor Drive End
8	4	282058	Bushing, R1-2 3/16 Split Tapered
9	2	980219	Bushing, Q1-1 15/16 Split Tapered

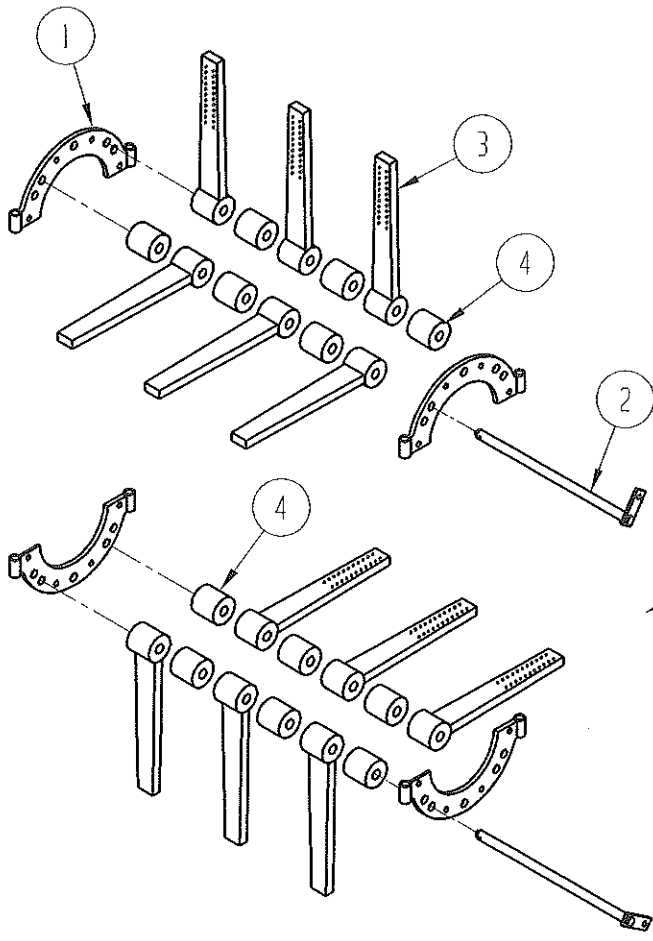

#2 Rotor
Cluster Assembly #281581

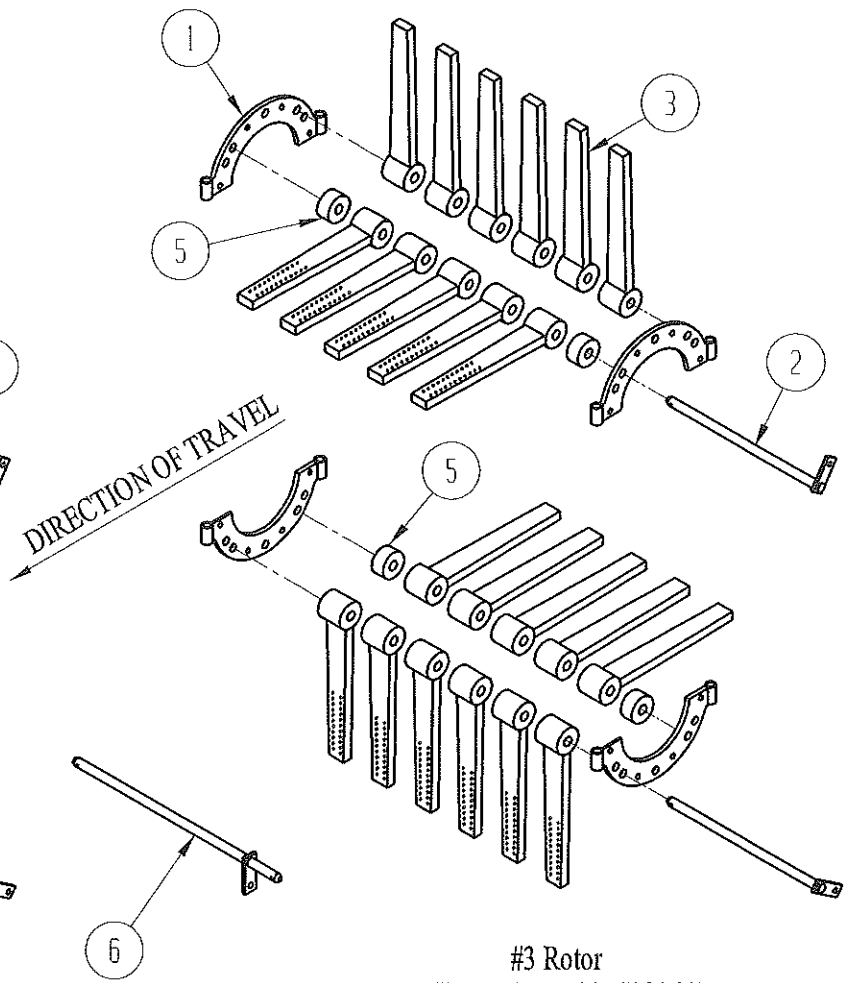

#3 Rotor
Cluster Assembly #282641

FLAIL CLUSTER ASSEMBLIES
(#2 & #3 Rotors)

ITEM NO.	QUANTITY PER CLUSTER	PART NO.	DESCRIPTION
1	4	281477	Half Clamp
2	4	281558	Flail Pin
3	12	281520	Rubber Flail (#2 Rotor)
	22	281520	Rubber Flail (#3 Rotor)
4	12	990588	Flail Spacer, 2" (#2 Rotor)
	-	-----	-----
5	4	281574	Flail Spacer, 1" (#3 Rotor Only)
6	As Req'd	281560	Flail Pin, Extended (For Extra Flails)

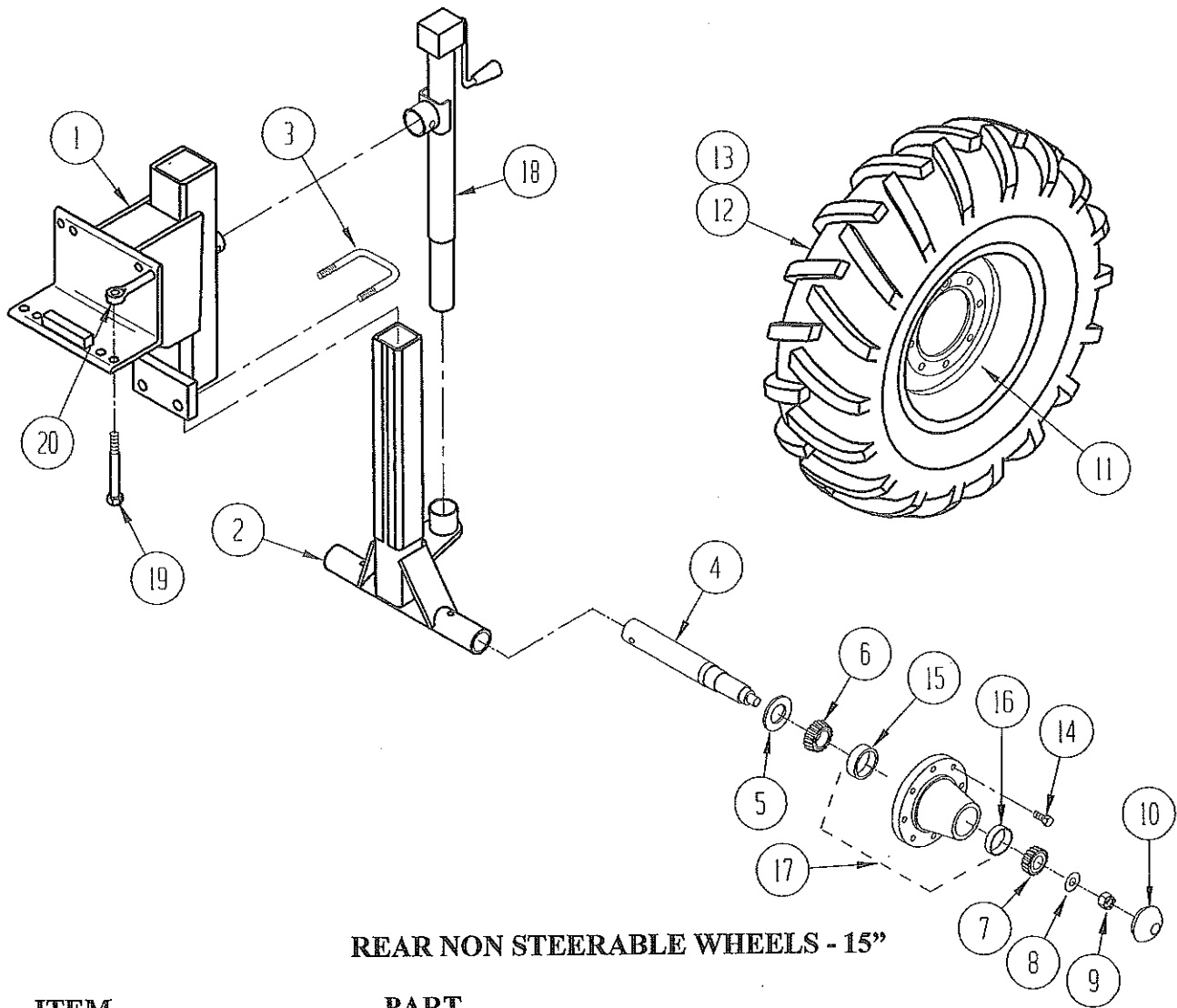

REAR NON STEERABLE WHEELS - 15"

ITEM NO.	QUANTITY	PART NO.	DESCRIPTION
1	2	282391	Rigid Strut
2	2	282386	Strut Bottom
3	2	282353	U-Bolt W/ Nuts
4	4	999992	Spindle
5	4	990099	Seal
6	4	990004	Bearing Cone, Inner
7	4	990006	Bearing Cone, Outer
8	4	999965	Flat Washer, 7/8
9	4	999960	Slotted Nut, 7/8
10	4	999951	Hub Cap
11	4	999953	Wheel Rim, 15" (6 Hole)
12	4	281140	Tire, 7.5 x 15 Traction Lug
13	4	999978.3	Tube, 7.5 x 15
14	24	999955	Lug Bolt
15	4	990005	Bearing Cup, Inner
16	4	990007	Bearing Cup, Outer
17	4	999995	Wheel Hub w/Cups (6 Bolt)
18	2	282358	Jack, Side Wind
19	8	-----	Hex Bolt, 3/4 x 6 1/2 NC
20	8	997903	Eye Bolt, 3/4 x 6 1/2

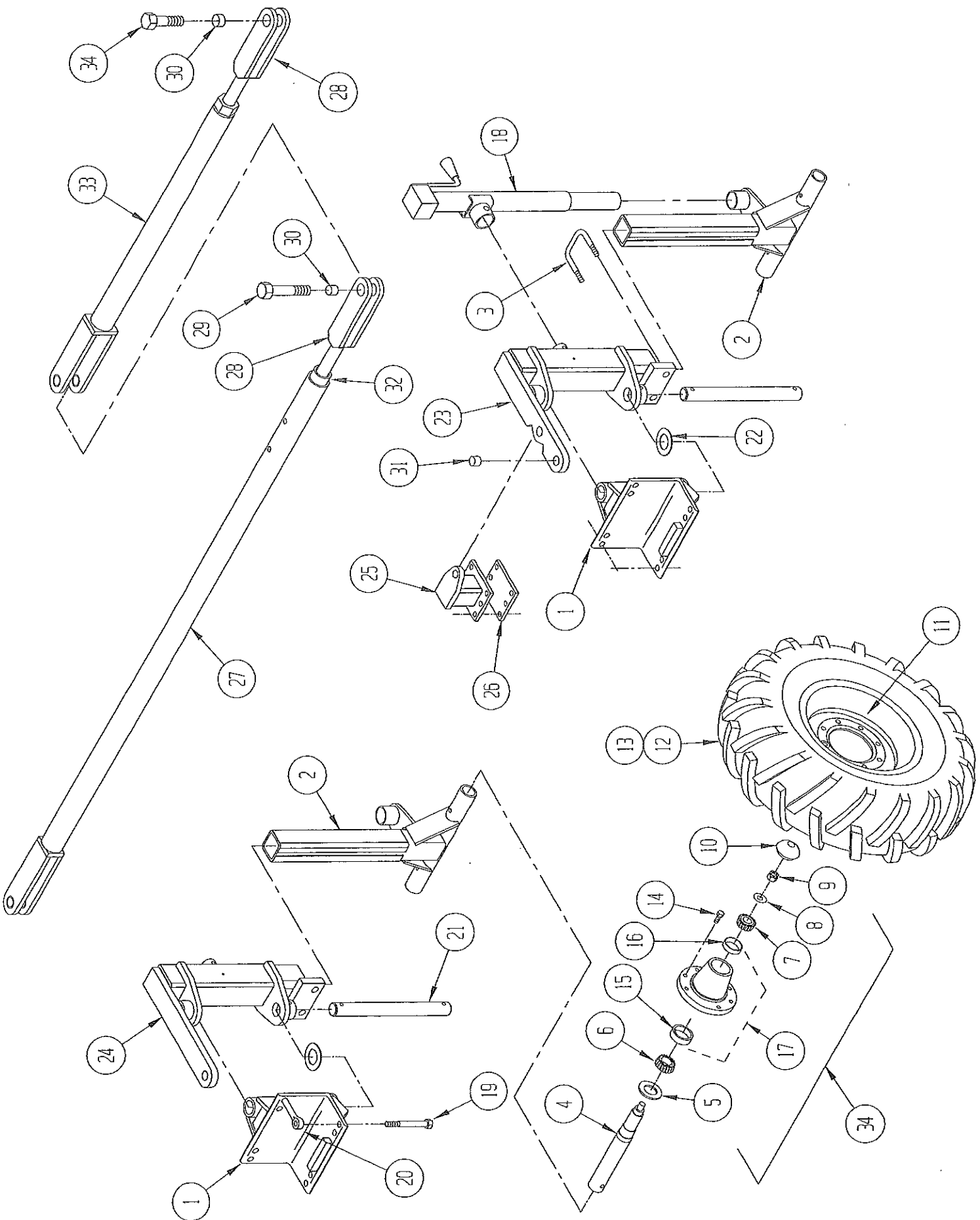

REAR STEERABLE WHEELS - 15"

ITEM NO.	QUANTITY	PART NO.	DESCRIPTION
1	4	281524	Strut Clamp
2	4	282386	Bottom Strut
3	4	282353	U-Bolt w/ Nuts
4	8	999992	Spindle
5	8	990099	Seal
6	8	990004	Bearing Cone, Inner
7	8	990006	Bearing Cone, Outer
8	8	999965	Flat Washer, 7/8
9	8	999960	Slotted Nut, 7/8
10	8	999951	Hub Cap
11	8	999953	Wheel Rim, 15" (6 Hole)
12	8	281140	Tire, 7.5 x 15 Traction Lug
13	8	999978.3	Tube, 7.5 x 15
14	48	999955	Lug Bolt
15	8	990005	Bearing Cup, Inner
16	8	990007	Bearing Cup, Outer
17	8	999995	Wheel Hub w/ Cups
18	4	282358	Jack, Side Wind
19	16	-----	Hex Bolt, 3/4 x 6 1/2
20	16	997903	Eye Bolt, 3/4 x 6 1/2
21	4	281537	Pivot Pin
22	4	281717	Wear Disk
23	1	282283	Top Steering Strut
24	3	282389	Top Standard Strut
25	1	281517	Cylinder Mount
26	1	281519	Base Plate
27	1	264405	Tie Rod Assembly, Complete
28	3	250098	Tie Rod End
29	2	-----	Hex Cap Screw, 1 x 6
30	8	990250	Hardened Bushing
31	5	990251	Hardened Bushing
32	1	264404	Extension Pipe
33	2	281538	Tie Rod Assembly, Complete
34	2	-----	Hex Cap Screw, 1 x 4

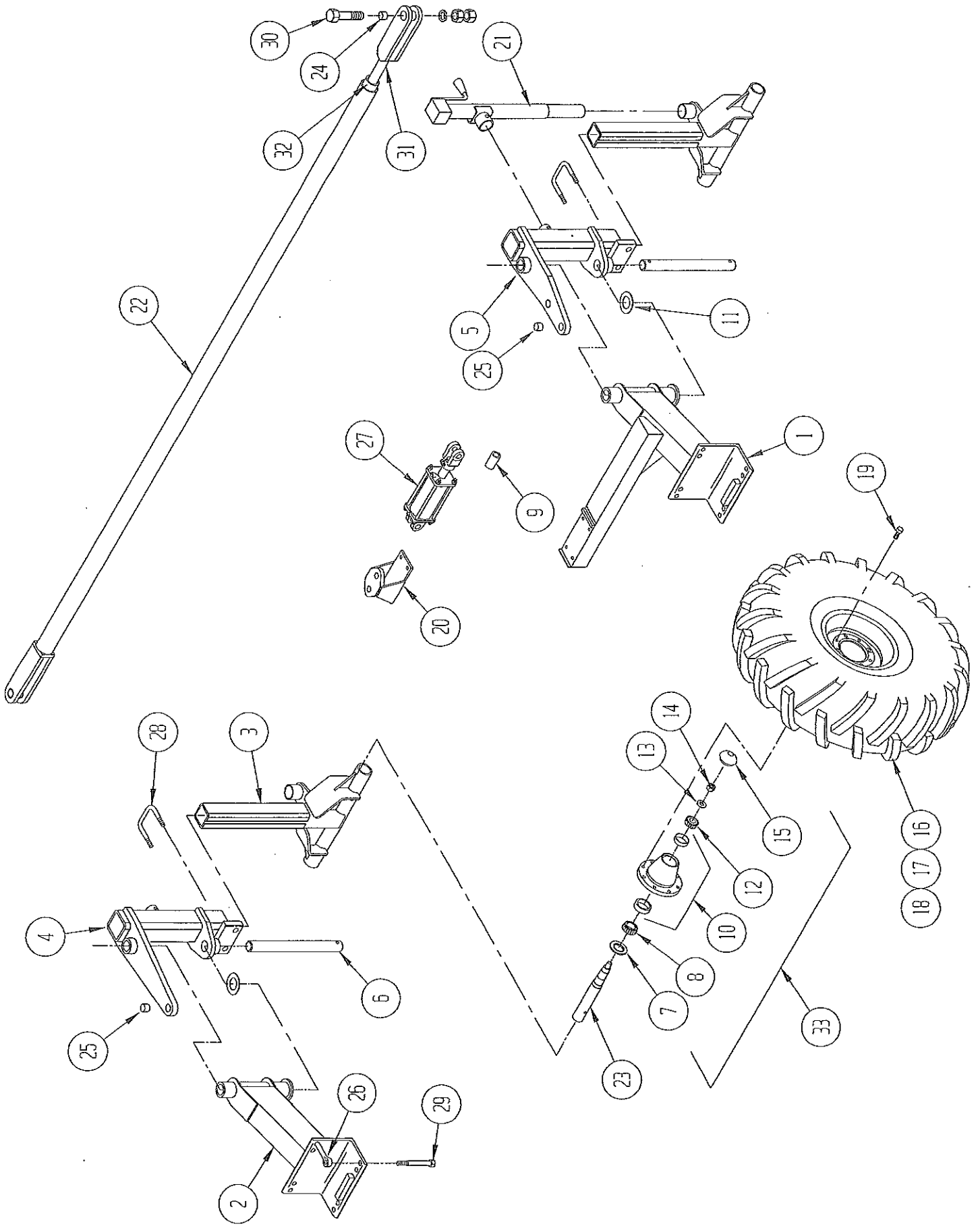

REAR STEERABLE WHEELS - 24"

ITEM NO.	QUANTITY	PART NO.	DESCRIPTION
1	1	282361	Steering Strut
2	1	281794	Standard Strut
3	2	282354	Bottom Strut
4	1	282359	Top Strut
5	1	282360	Top Steering Strut
6	2	281357	Pivot Pin
7	4	990094	Seal
8	4	990000	Inner Cone
9	1	265012	Cylinder Stop
10	4	999964	Wheel Hub w/ Cups
11	2	282178	Wear Disk
12	4	999002	Outer Cone
13	4	999965	Flat Washer, 7/8"
14	4	999960	Castle Nut, 7/8-14
15	4	999952	Hub Cap
16	4	331224	Tire, 11.2" x 24"
17	4	300045	Tube, 24"
18	4	300046	Wheel, 24"
19	32	997905	Lug Bolt
20	1	265233	Cylinder Ear
21	2	282358	Jack, Side Wind
22	1	282103	Tie Rod Asm Complete
23	4	999956	Spindle
24	4	990250	Hardened Bushing
25	3	990251	Hardened Bushing
26	8	997903	Eye Bolt, 3/4" x 6 1/2"
27	1	998943	Hydraulic Cylinder, 3" x 6" Stroke
28	2	282353	U-Bolt
29	8	-----	Hex Bolt, 3/4" x 9"
30	2	-----	Hex Bolt, 1" x 4"
31	1	250098	Tie Rod End
32	1	282106	Extension Pipe
33	4	999981	Hub Asm (Complete w/ Lug Bolts)

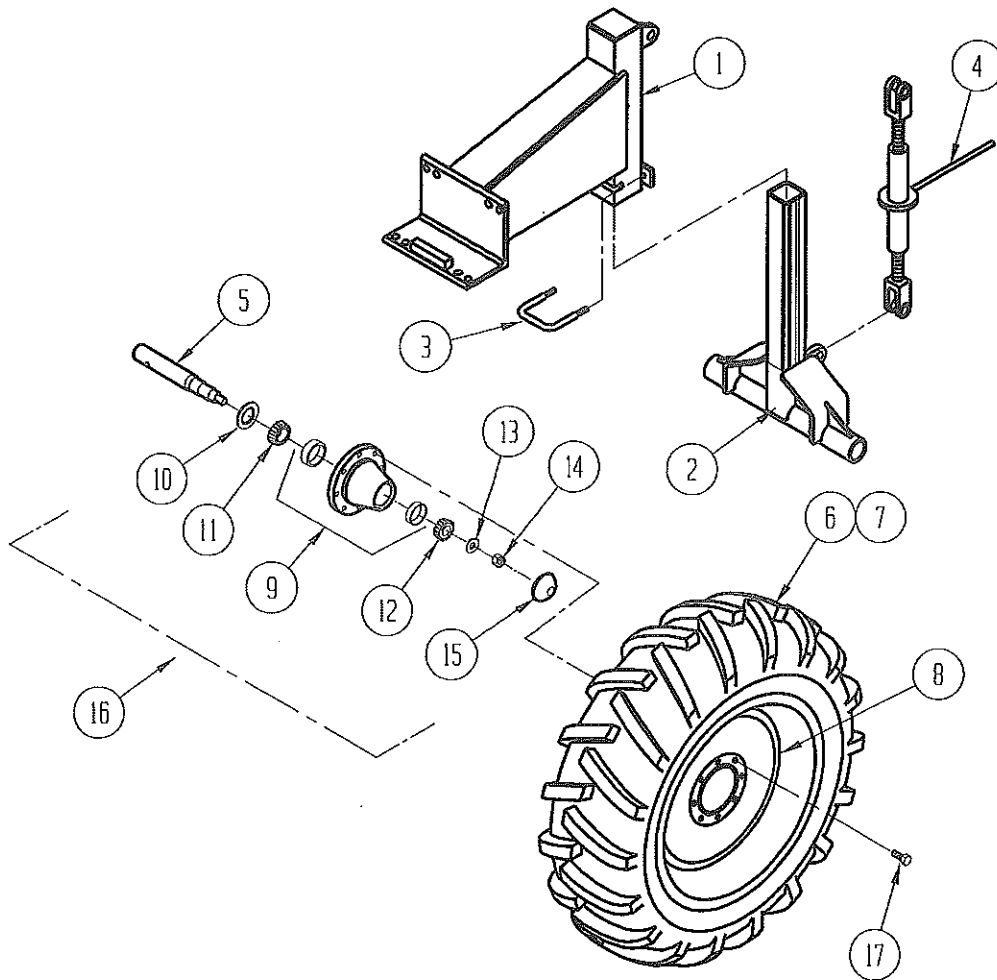

REAR NON STEERABLE WHEELS - 24"

ITEM NO.	QUANTITY	PART NO.	DESCRIPTION
1	2	282382	Rigid Strut
	1	282514	Center Strut(not shown)
2	2	282354	Bottom Strut
	2	282480	Bottom Strut, 44"(Optional)
3	2	282353	U-Bolt w/ Nuts
4	2	282358	Jack, Side Wind
5	4	999956	Spindle
6	4	331224	Tire, 11.2" x 24"
7	4	300045	Tube, 24"
8	4	300046	Wheel, 24"
9	4	999964	Wheel Hub w/ Cups
10	4	990094	Seal
11	4	990000	Inner Cone
12	4	999002	Outer Cone
13	4	999965	Flat Washer, 7/8"
14	4	999960	Castle Nut, 7/8-14
15	4	999952	Hub Cap
16	4	999981	Hub Assembly (Complete w/ Lug Bolts)
17	32	997905	Lug Bolt

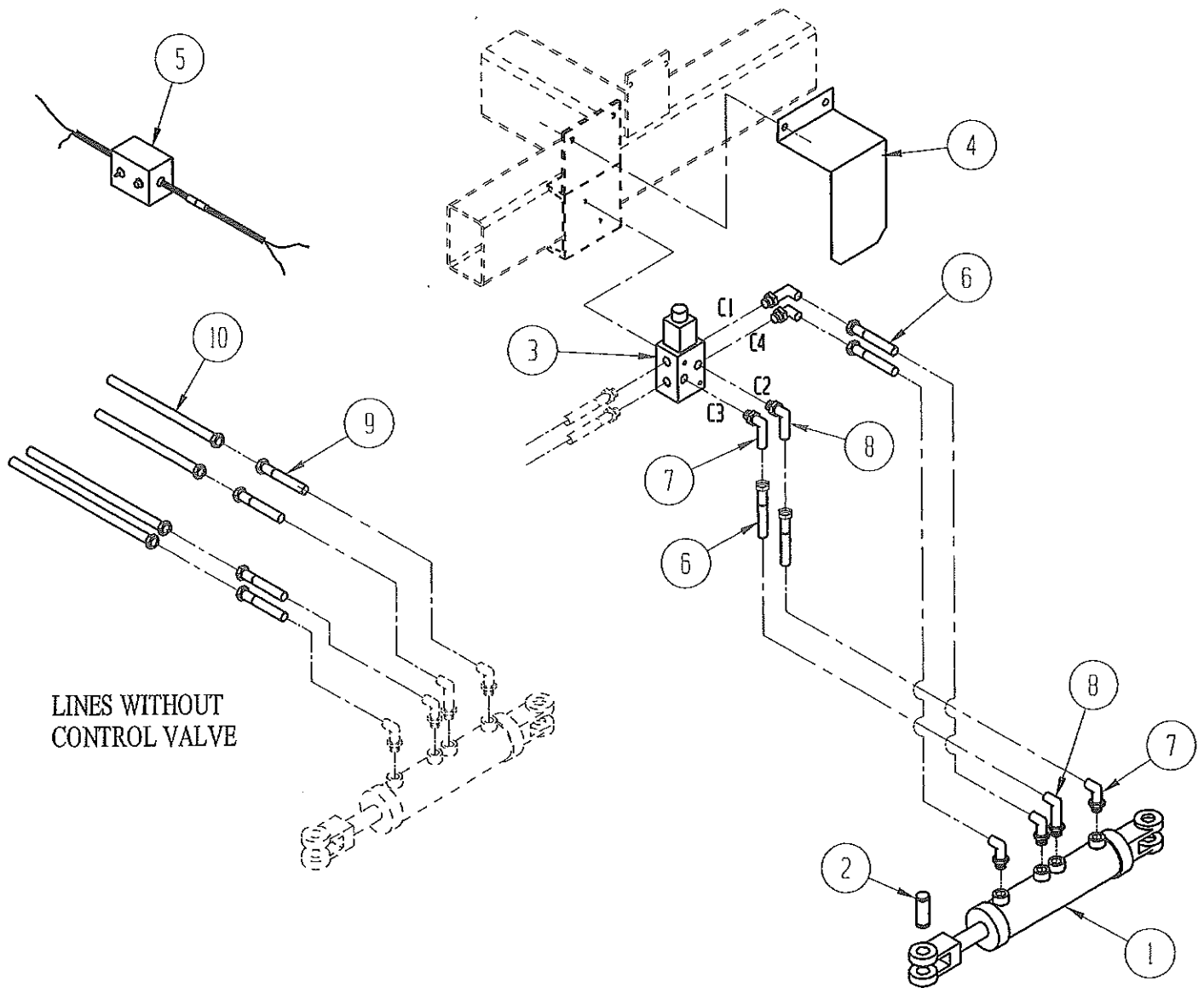

TWO WAY STEERING

ITEM NO.	QUANTITY	PART NO.	DESCRIPTION
1	1	265226	Hydraulic Cylinder, Double Rod
2	2	265254	Cylinder Pin
3	1	265237	Selector Valve
4	1	281285	Valve Cover
5	1	999077	Switch Box Assembly
6	4	-----	Hydraulic Hose, 1/2 x 50" w/ 1/2" JIC Female Swivel Ends
7	5	2503-8-8	90° Short Elbow
8	3	5603-8-8	90° Long Elbow
9	4	-----	Hydraulic Hose, 1/2 x 60" w/ 1/2" JIC Male & 1/2" JIC Female Swivel Ends
10	4	-----	Hydraulic Tube Assembly, 5/8 x 96"

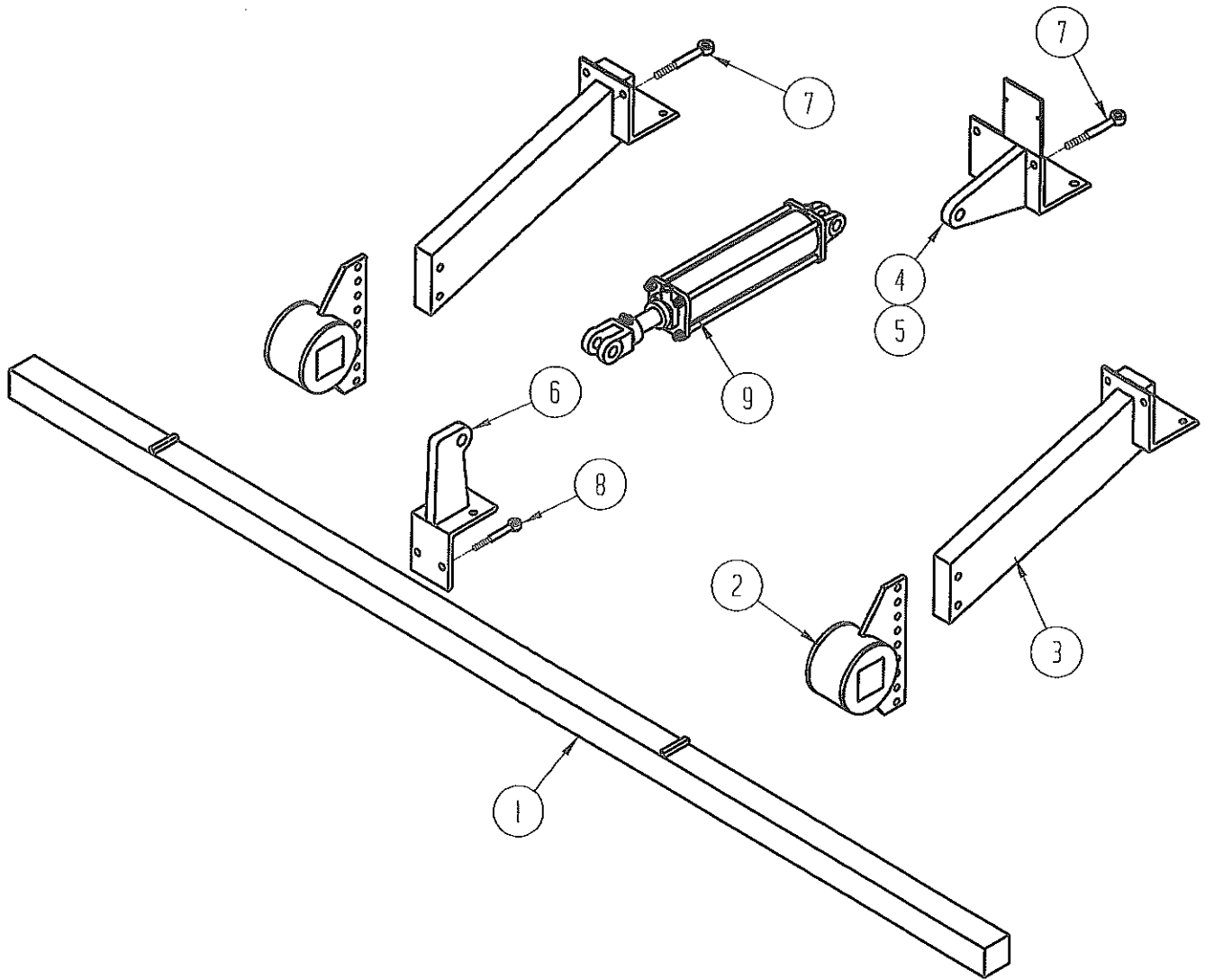

SCALPER TOOL BAR ASSEMBLY
(For Unit With 15" Rear Carrier Wheels)

ITEM NO.	QUANTITY	PART NO.	DESCRIPTION
1	2	281825	Tool Bar
2	4	281089	Tool Bar Support
3	4	281547	Tool Bar Mount
4	1	281550	Cylinder Ear, LH
5	1	281586	Cylinder Ear, RH
6	2	281553	Lift Ear
7	12	997903	Eye Bolt, $\frac{3}{4}$ x 6 $\frac{1}{2}$
8	4	281978	Eye Bolt, $\frac{5}{8}$ x 5
9	2	267835	Hydraulic Cylinder, 3" x 8" Stroke

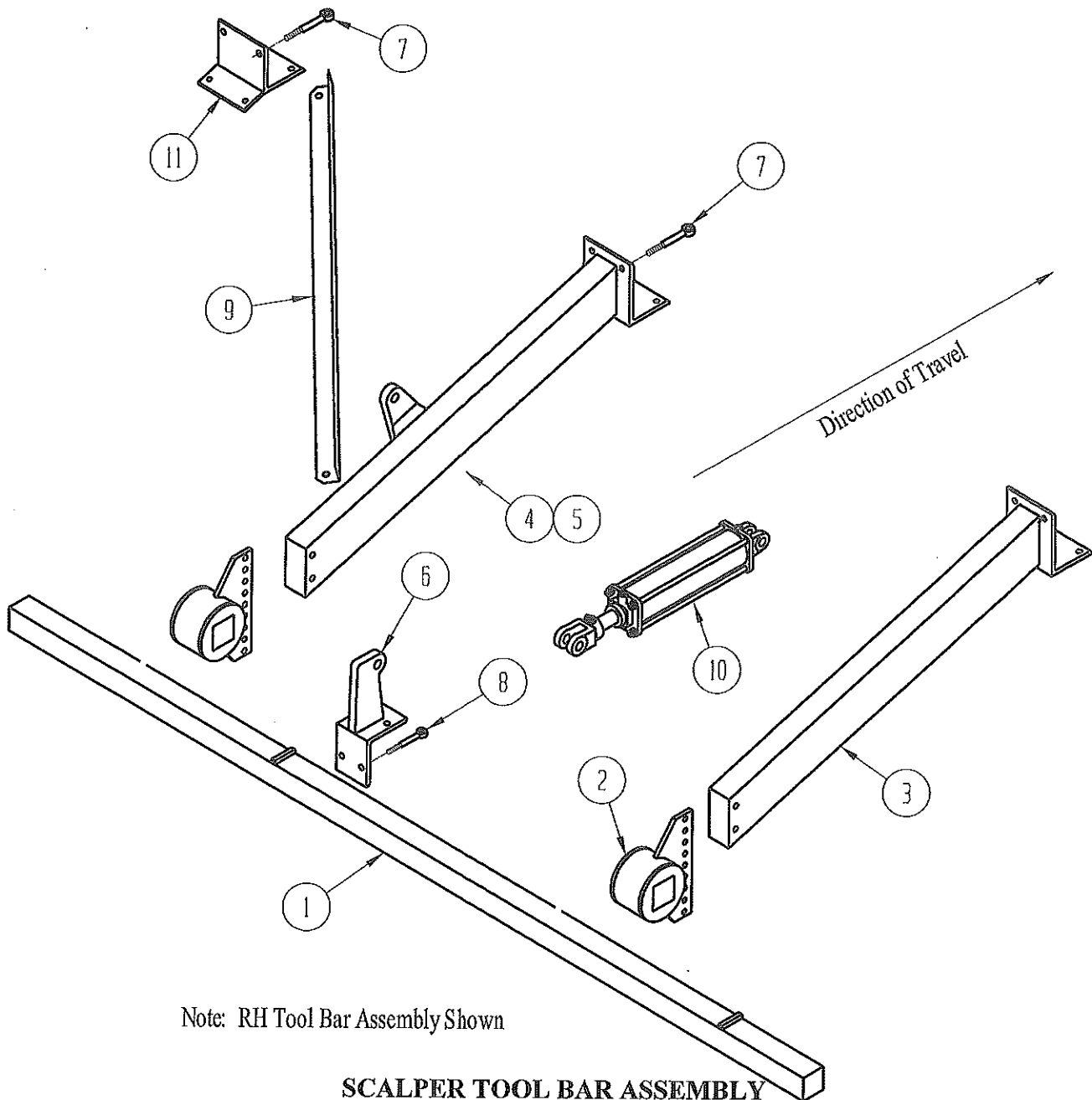

Note: RH Tool Bar Assembly Shown

SCALPER TOOL BAR ASSEMBLY
(For Unit With 24" Rear Carrier Wheels)

ITEM NO.	QUANTITY	PART NO.	DESCRIPTION
1	2	282177	Tool Bar
2	4	281089	Tool Bar Support
3	2	281808	Tool Bar Mount, Outside
4	1	281809	Tool Bar Mount, LH Inside (Not Shown)
5	1	282112	Tool Bar Mount, RH Inside
6	2	281553	Lift Ear
7	10	997903	Eye Bolt, 3/4" x 6 1/2"
8	4	281978	Eye Bolt, 5/8 x 5
9	2	282110	Tool Bar Brace(not used with center strut)
10	2	267835	Hydraulic Cylinder, 3" x 8" Stroke
11	1	282109	Brace Bracket

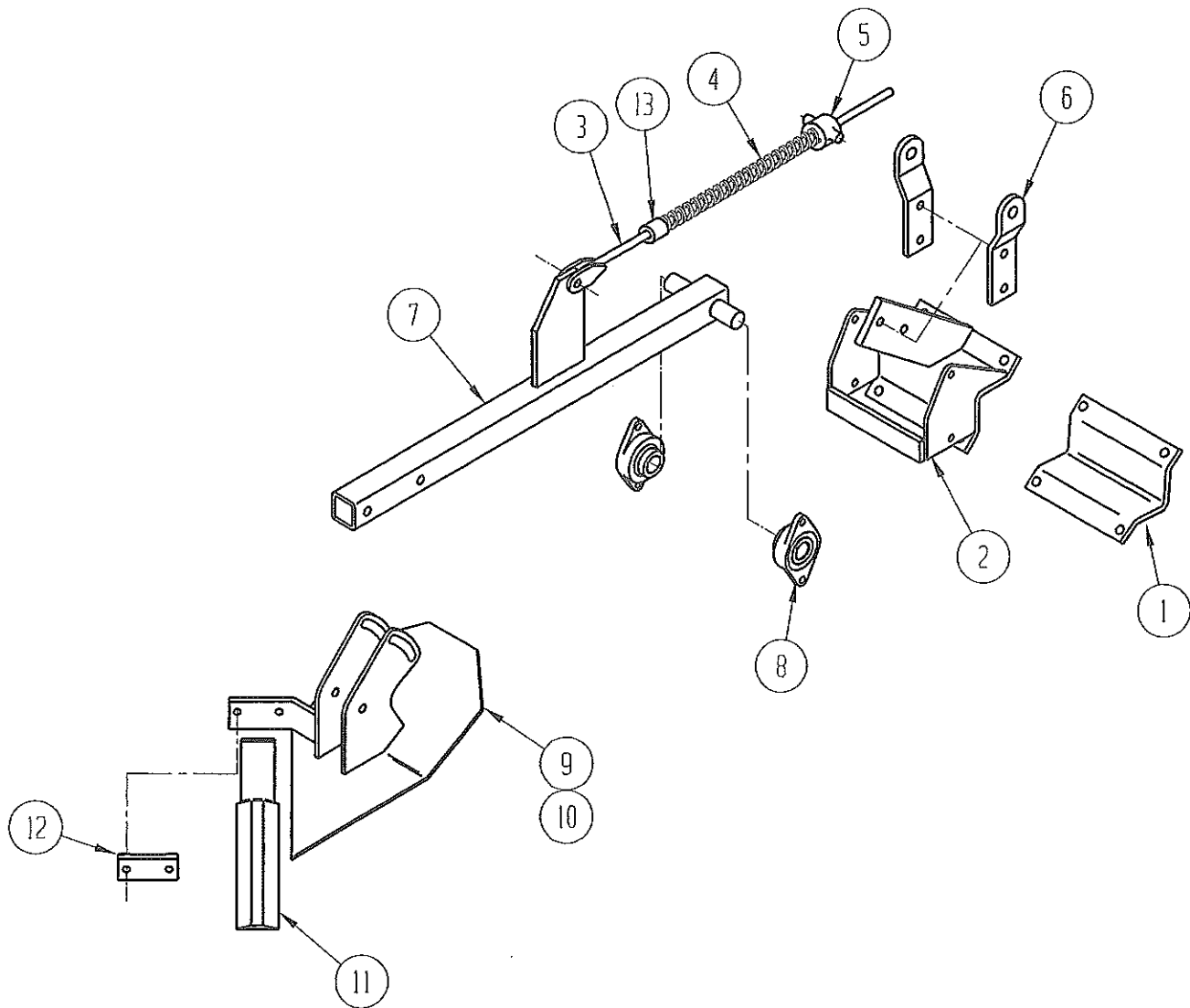

KNIFE SCALPER HEAD ASSEMBLY
(LH # 282179, RH #282180)

ITEM NO.	QUANTITY	PART NO.	DESCRIPTION
1	1	281108	Half Clamp
2	1	282182	Mount Weldment
3	1	281121	Adjustment Bar
4	1	990742	Spring
5	1	281096	Trunnion
6	2	281095	Trunnion Ear
7	1	281352	Scalper Arm
8	2	980185	Bearing, 1 1/8 2 Bolt Flanged
9	1	281120	LH Scalper Shoe (Shown)
10	1	281123	RH Scalper Shoe (Opposite)
11	1	281116	Knife Blade
12	1	281129	Blade Clamp
13	1	281114	Set Collar

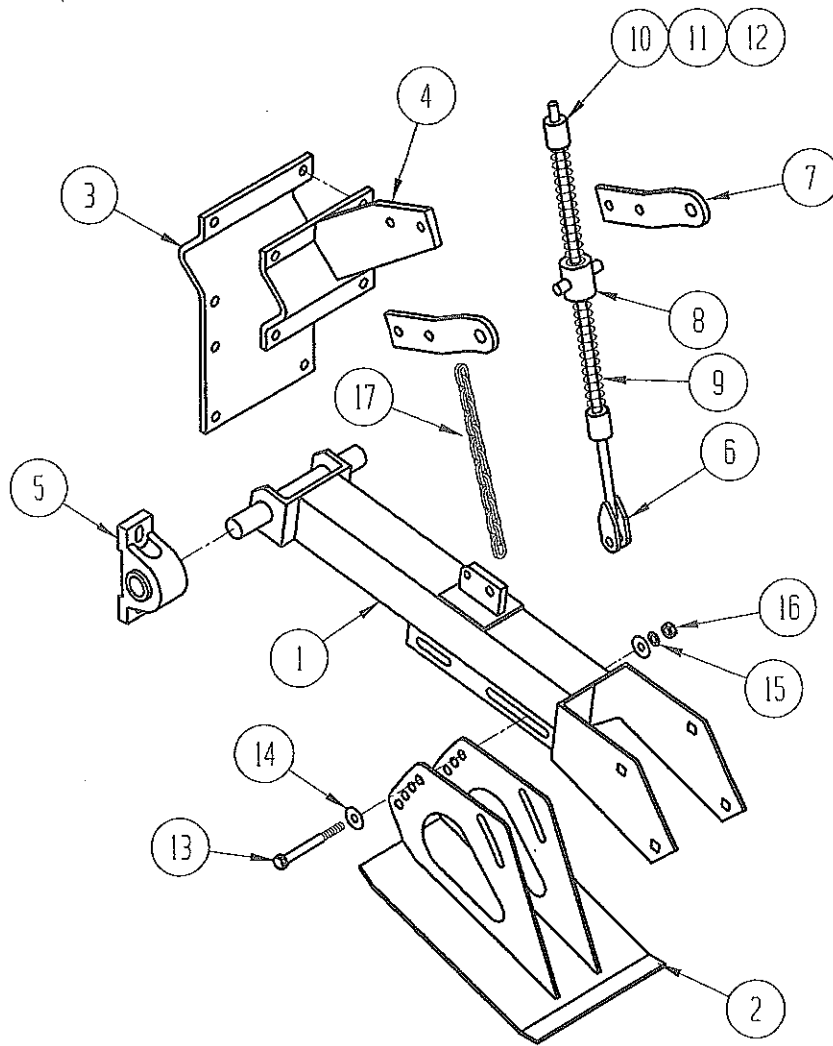

SCALPER ARM ASSEMBLY
(Ground Driven & Hydraulic Driven Scalpers)

ITEM NO.	QUANTITY	PART NO.	DESCRIPTION
1	1	282113	Scalper Arm
2	1	282119	Scalper Shoe
3	1	281318	Bearing Hanger
4	1	282128	Rear Clamp
5	2	980022	Pillow Block Bearing, 1 3/16"
6	1	281121	Adjustment Bar
7	2	281095	Trunnion Ear
8	1	281096	Trunnion
9	2	281912	Spring
10	2	281114	Set Collar
11	2		Square Head Set Screw, 3/8" x 1"
12	2		Jam Nut, 3/8"
13	2		Hex Cap Screw, 1/2 x 4 1/2
14	2		Flat Washer, 1/2
15	2		Lock Washer, 1/2
16	2		Hex Nut, 1/2
17	1		Log Chain, 3/16 x 15"

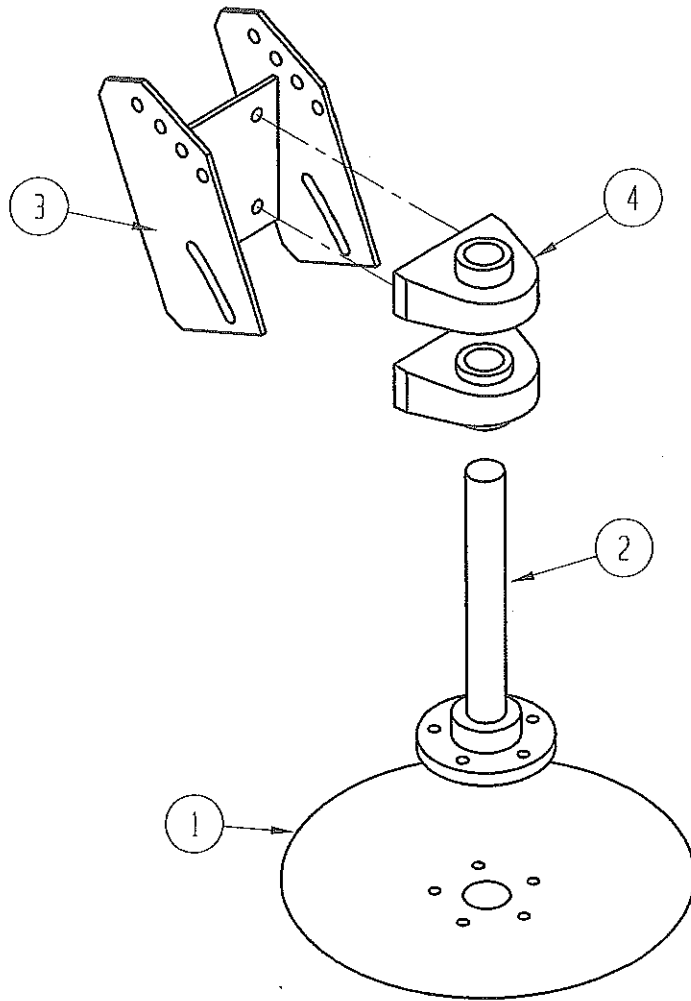

GROUND DRIVEN DISK ASSEMBLY

ITEM NO.	QUANTITY	PART NO.	DESCRIPTION
1	1	282138	Disk
2	1	282140	Disk Shaft
3	1	282141	Disk Mounting Bracket
4	2	980200	Bearing, 1 3/16" Tapped Base

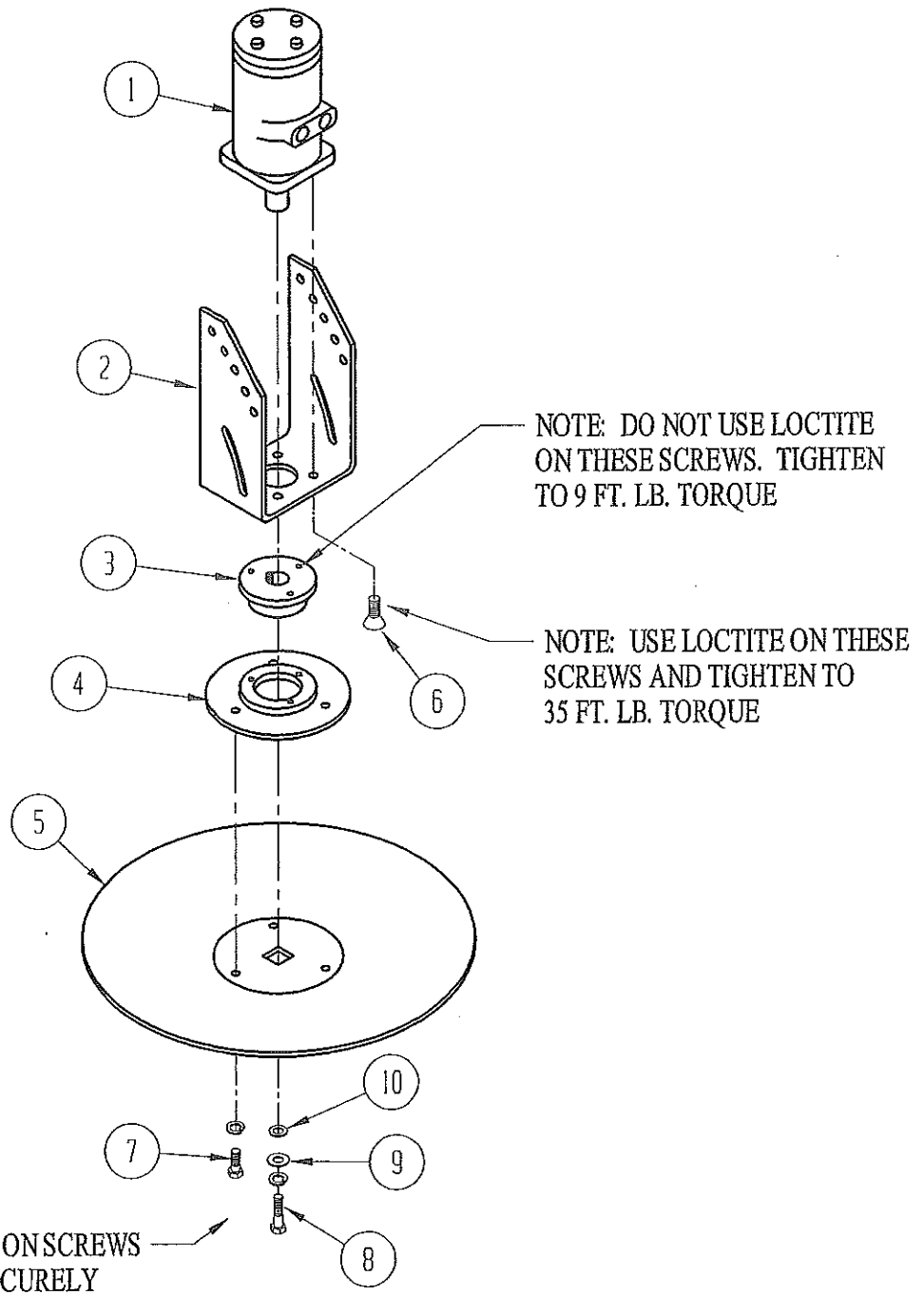

HYDRAULIC DRIVEN DISK ASSEMBLY

ITEM NO.	QUANTITY	PART NO.	DESCRIPTION
1	1	990456	Hydraulic Motor
2	1	281321	Motor Mount
3	1	980278	Bushing, SDS 1"
4	1	281286	Disk Mount
5	1	990921	Disk
6	4	281360	Flat Socket Head Cap Screw, 3/8" x 3/4"
7	3		Hex Cap Screw, 3/8" x 3/4"
8	1		Hex Cap Screw, 1/4" x 1"
9	1		Fender Washer, 1/4"
10	1		Flat Washer, 1/4"

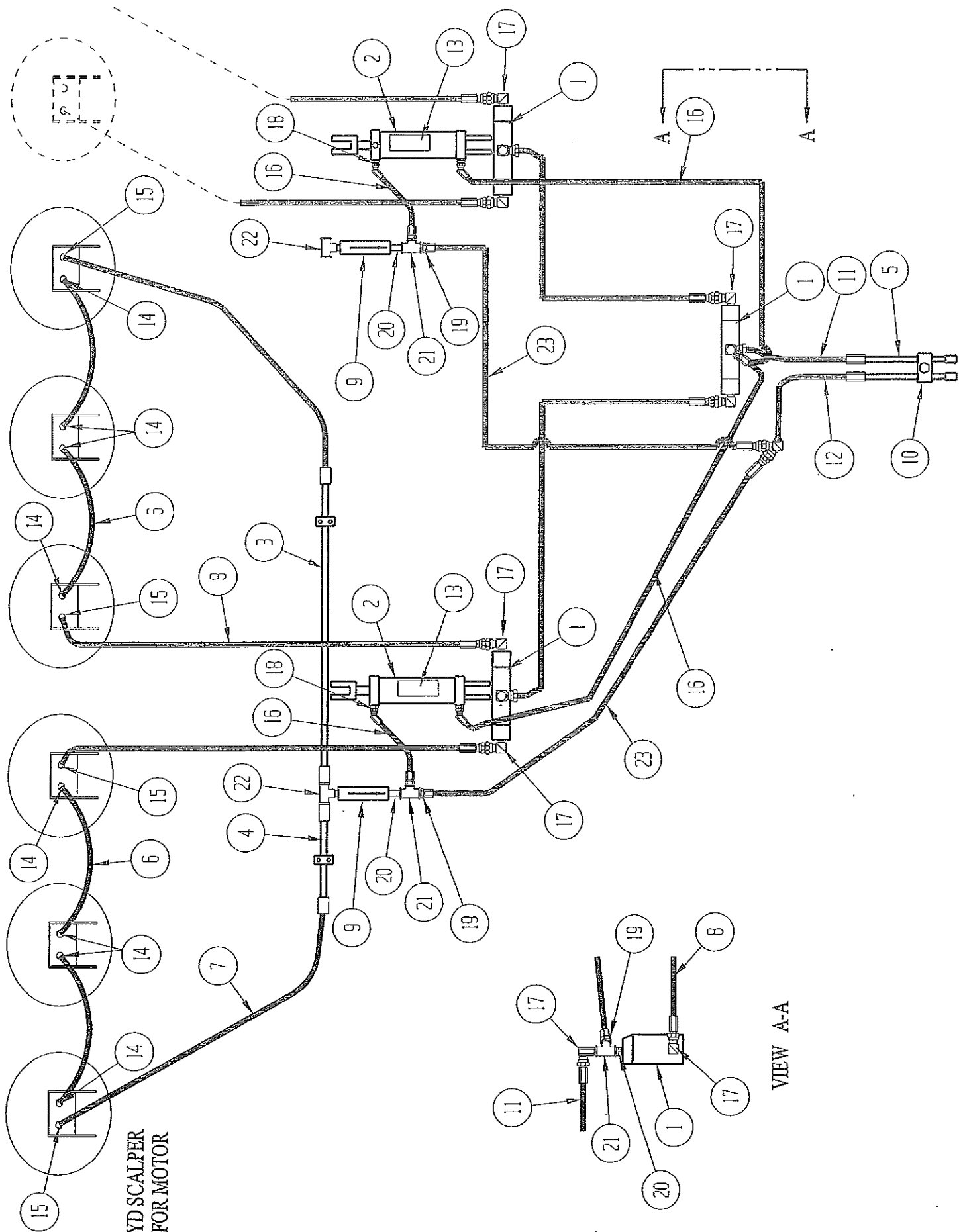

SEE HYD SCALPER
PAGE FOR MOTOR

VIEW A-A

HYDRAULIC DISK SCALPER HYDRAULICS

ITEM NO.	QUANTITY	PART NO.	DESCRIPTION
1	3	990922	Flow Divider
2	2	998903	Hydraulic Cylinder, 3 x 8
3	2	-----	Hydraulic Tube Assembly, 5/8 x 32
4	2	-----	Hydraulic Tube Assembly, 5/8 x 28
5	2	-----	Hydraulic Tube Assembly, 5/8 x 90
6	8	-----	Hydraulic Hose, 1/2 x 28 w/ 1/2 JIC Female Swivel Ends
7	4	-----	Hydraulic Hose, 1/2 x 57 w/ 1/2 JIC Male & 1/2 JIC Female Swivel Ends
8	2	-----	Hydraulic Hose, 1/2 x 70 w/ 1/2 JIC Female Swivel Ends
9	2	281084	Check Valve
10	2	264704	Line Clamp, 5/8
11	1	-----	Hydraulic Hose, 1/2 x 18 w/ 1/2 JIC Male & 1/2 JIC Female Swivel Ends
12	1	-----	Hydraulic Hose, 1/2 x 48 w/ 1/2 JIC Male & 1/2 JIC Female Swivel Ends
13	2	100408	Decal
14	16	6802-8-10	O-Ring Adapter, 45°
15	8	6400-8-10	O-Ring Adapter
16	4	-----	Hydraulic Hose, 1/2 x 24 w/ 1/2 JIC Female Swivel Ends
17	6	6501-8-8	90° Elbow
18	4	6400-8-10	O-Ring Adapter
19	4	2404-8-8	Adapter
20	4	5404-8-8	Close Nipple
21	2	5605-8-8-8	Tee
22	2	2601-8-8-8	Tee
23	2	-----	Hydraulic Hose, 1/2 x 48 w/ 1/2 JIC Female Swivel Ends

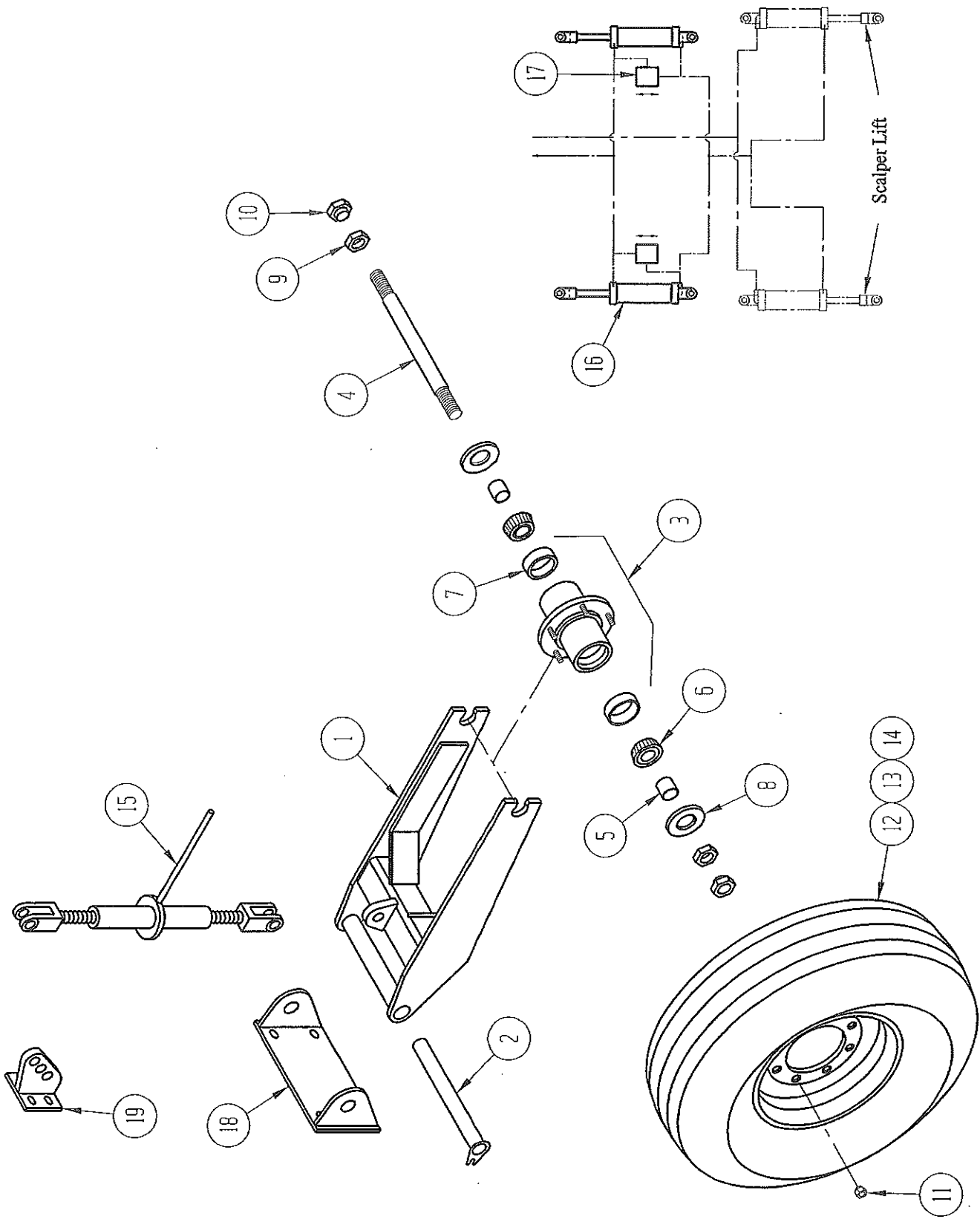

FRONT GAUGE WHEEL ASSEMBLY

ITEM NO.	QUANTITY	PART NO.	DESCRIPTION
1	2	281711	Wheel Frame
2	2	281713	Pivot Shaft
3	2	334448	Wheel Hub w/ Cups
4	2	281602	Axle
5	4	281601	Bushing
6	4	334136	Bearing Cone
7	4	334276	Bearing Cup
8	4	334902	Seal
9	4	331273	Jam Nut
10	4	331274	Shoulder Nut
11	10	330417	Lug Nut
12	2	281603	Wheel, 15 x 6" 5 Bolt
13	2	999978	Tire, 7.6 x 15" 8 Ply
14	2	999978.3	Tube, 15"
15	2	990770	Screw Jack
16	2	998943	Hydraulic Cylinder, 3 x 6
17	2	290126	Relief Valve
18	2	282010	Mounting Bracket
19	2	282006	Cylinder Ear

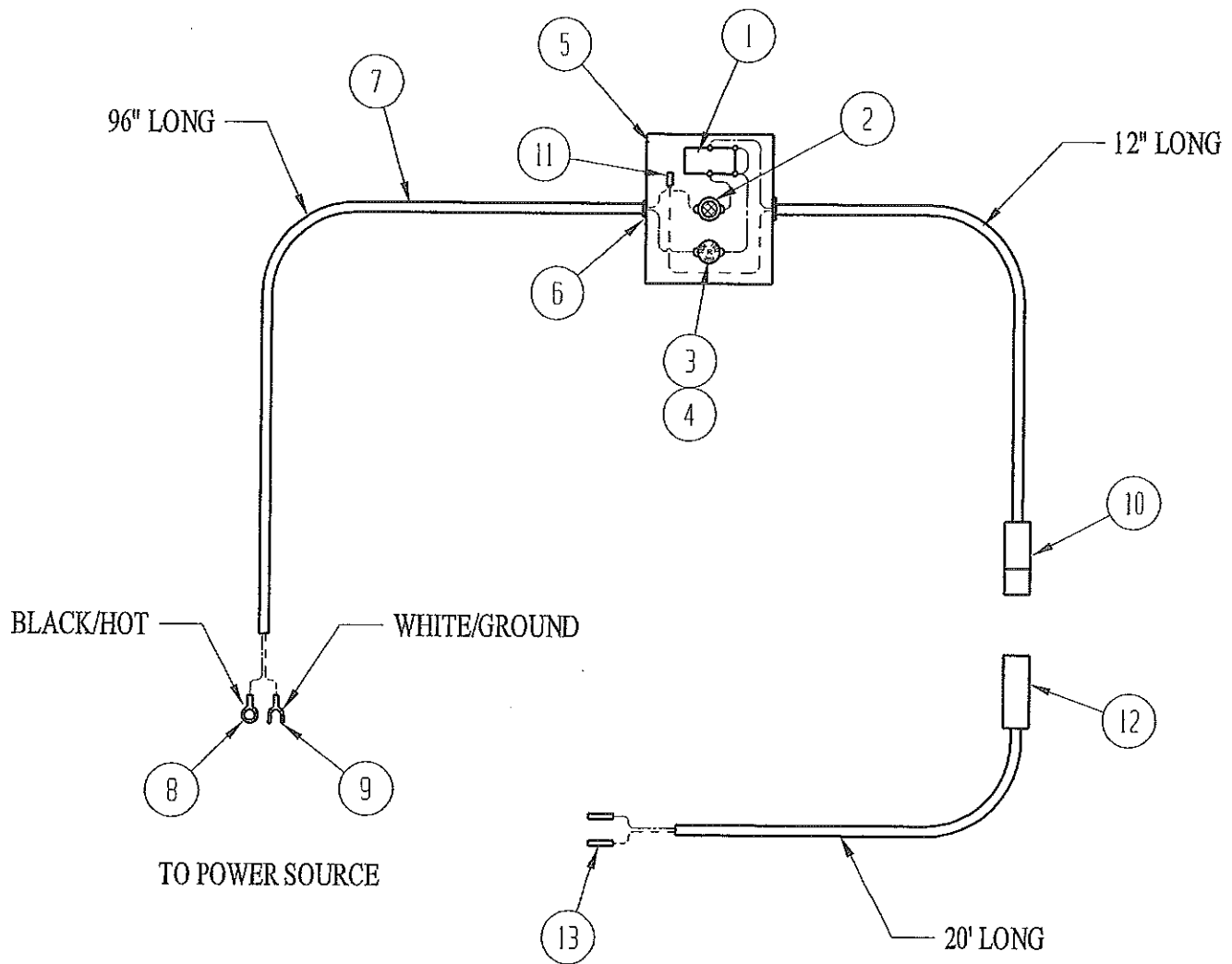

ELECTRICAL SWITCH BOX ASSEMBLY
(#999077)

ITEM NO.	QUANTITY	PART NO.	DESCRIPTION
1	1	999145	Toggle Switch, 3A.125V
2	1	100150	Light
3	1	999146	Fuse Holder
4	1	999152	Fuse, 20 AMP
5	1	999154	Box Chassis
6	3	999151	Rubber Grommet
7	29 Ft.	999274	Wire, 16/2 Type SJ
8	1	999270	Ring Tongue Terminal, 16 Ga.
9	1	999271	Spade Tongue Terminal, 16 Ga.
10	1	999148	Female Connector Half, 2 Wire
11	1	999316	Wire Nut, 14-22
12	1	999149	Male Connector Half, 2 Wire
13	2		Butt Connector, 16/2

NOTES